

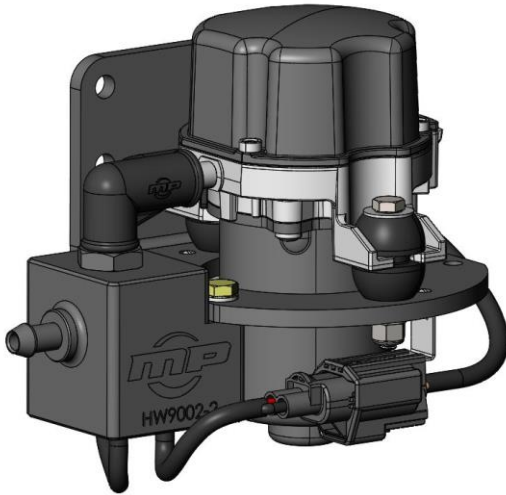

# Master Power Brakes Electric Vacuum Pump Kit Various Applications P/N: AC9001K

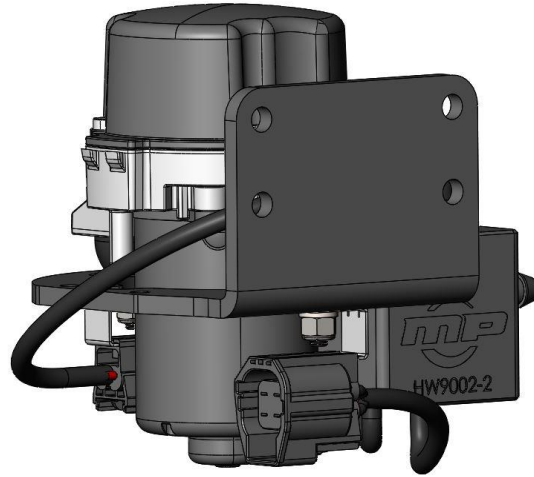

**Front**



**Back**

Thank you for purchasing the Master Power Brakes Silent Drive Electric Vacuum Pump Kit. If you are running a radical cam and therefore down on engine vacuum but still looking for the feeling in your brake pedal that a vacuum booster should provide, then you have made the right choice. In years past and in some systems today, the drawback to a vacuum pump has always been the noise and how quick it can recover. With the Master Power Brakes Silent Drive Vacuum Pump, both of these problems are no longer problems.

| Parts List |   |
|------------|---|
| Quantity   | Description   |
| 1          | Electric Vacuum Pump                                    |
| 1          | Wiring Harness (Includes 10' of wire for each terminal) |
| 1          | Vacuum Pump Control Module                              |
| 1          | Powdercoated Black Mounting Bracket                     |
| 1          | 10-feet 11/32" Vacuum Hose                              |
| 4          | 5/16"-18 x 1-1/2" Grade 8 Hex Head Bolts                |
| 4          | 5/16" SAE Flatwasher                                    |
| 4          | 5/16"-18 Flanged Hex Nuts                               |
| 1          | Posi Lock Fuse Holder w/ 15amp Fuse                     |
| 1          | #10 Non-Insulated Ring Terminal – 18-gauge wire         |
| 1          | #10 Non-Insulated Ring Terminal – 14-gauge wire         |
| 1          | 3/8" Non-Insulated Ring Terminal – 14-gauge wire        |
| 1          | Non-Insulated Wire Splice – 18-gauge wire               |
| 1          | Non-Insulated Wire Splice – 14-gauge wire               |
| 2          | #10 x 3/4" Hex Head Drill Screws                        |
| 4          | 1/4" x 1-1/4" Heat Shrink Tubing                        |

## **Pump Installation:**

1. Find a suitable location to mount the pump. Use the template located on Page 5 of the instructions to aid in finding a suitable mounting location along with locating the bracket mounting holes. **IMPORTANT:** The pump must be mounted vertical. Mounting the pump horizontally will cause the pump to operate incorrectly.
2. If desired, the vacuum pump orientation within the mounting can be rotated so the vacuum hose exits on the opposite side. To do so, remove the M6-1.0 x 50mm Hex Head Bolts and Nuts holding the pump to the bracket and the 1/4"-20 x .750" Hex Head Bolts holding the module to the bracket. It is not necessary to remove the hose elbow. Within the bracket, rotate the pump and module and re-install the mounting hardware. Be sure and put the wiring harness retaining clips in place when re-assembling the pump in the new location.
3. Mount the bracket using the provided 5/16"-18 x 1-1/2" Grade 8 Hex Head Bolts along with the 5/16" SAE Flatwasher and 5/16"-18 Flanged Hex Nuts. Torque the bolts to 25 ft/lbs.

## **Wiring Harness Installation:**

1. Connect the wiring harness to the previously mounted pump assembly. Insert the male 4-pin connector from the wiring harness into the female 4-pin connector on the vacuum pump assembly. Make sure that you hear and feel a "click" when doing so, this will let you know the connectors are fully mated. Also, the connector can only be installed one way. Refer to Figure 1 below for reference.

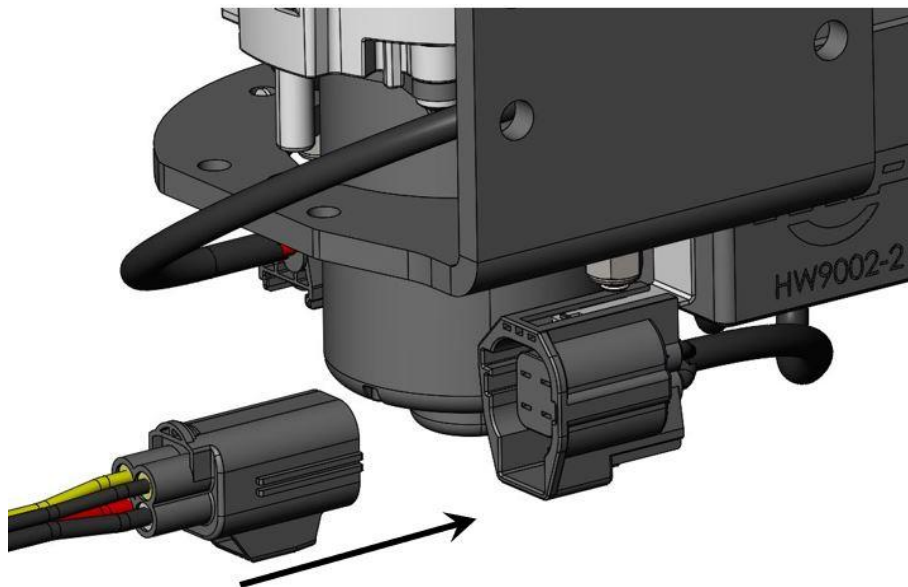

Figure 1 – Installing the 4-Pin Connector

2. Terminate each of the 4 wires in the wiring harness at their respective locations. See Figure 2 on the following page for reference.

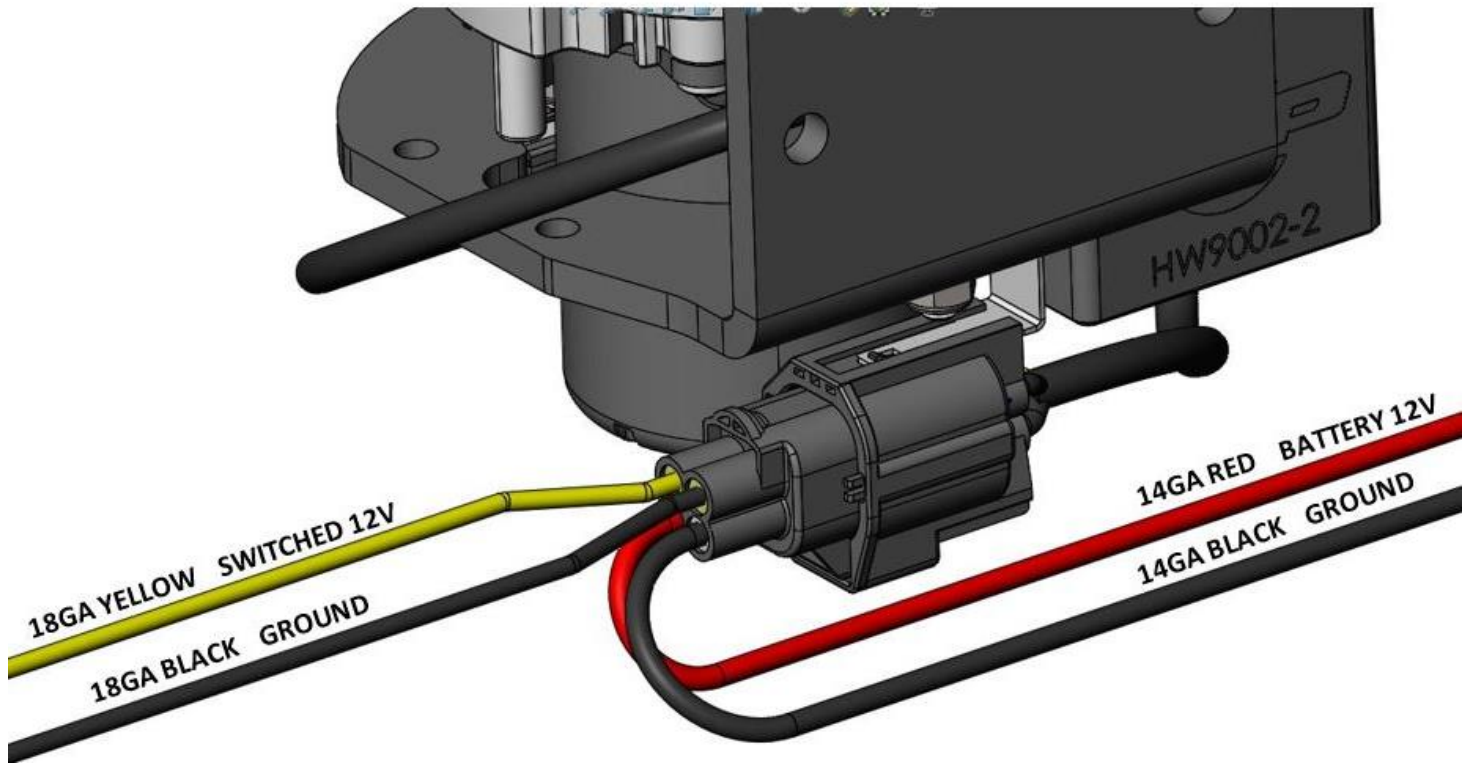

Figure 2 – Wiring Harness Wire Routing

### **Wire Termination:**

1. Attach the 14-gauge red power wire to a constant 12-volt power source, preferably the battery. If required, use the provided 3/8" Non-Insulated 14-gauge Ring Terminal to connect to the power source. Use the 1/4" x 1-1/4" Heat Shrink Tubing to cover and protect the connection.
2. Within 12 inches of the battery, cut the wire and install the Posi-Lock Fuse Holder. Figure 3 below shows the proper steps on how to install the fuse holder.

### **Step 1**

Strip Wire 1/2"



### **Step 2**

Insert Stripped Wire into Threaded Ends

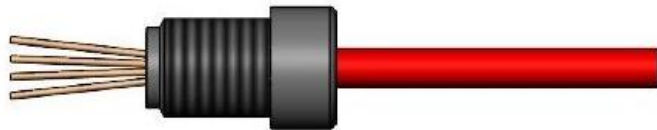

### **Step 3**

Insert Wire and Threaded Ends into Fuse Holder and Tighten

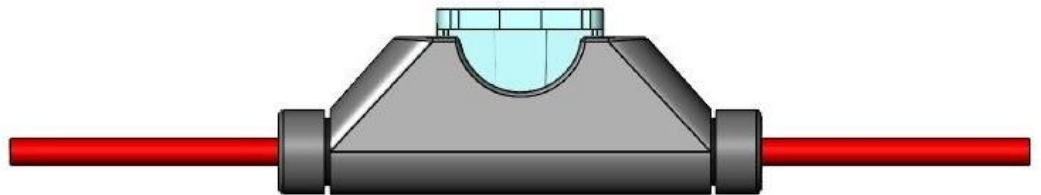

Figure 3 – Posi-Lock Fuse Holder Installation

3. Attach the 18-gauge yellow power wire to a suitable switched 12-volt power source. Provided in the kit are two Non-Insulated Wire Splices that can be used depending on the wire size being spliced into. Use the one that is the proper size for the wire being spliced. After splicing and crimping, cover and protect the connection with a piece of 1/4" x 1-1/4" Heat Shrink Tubing provided with the kit.
4. Attach both the 14-gauge and the 18-gauge black ground wire to a proper chassis grounding location. Secure them both by crimping the provided #10 Non-Insulated Ring Terminals to each of the wires. Cover and protect the crimps with a piece of the provided 1/4" x 1-1/4" Heat Shrink Tubing. If required, use #10 x 3/4" Hex Head Drill Screws that are included to attach the ring terminal to the chassis.

### **Vacuum Hose:**

1. Run the vacuum hose from the machined hose barb on the pump module to the brake booster. Use whatever is necessary of the provided 11/32" Vacuum Hose for installation. Additional hose can be obtained locally or by contacting Master Power Brakes for more. **IMPORTANT:** If obtaining additional hose locally, be sure to pick up 11/32" Vacuum Hose. Anything else is unacceptable.

### **Troubleshooting:**

| <b>Fault</b>               | <b>Possible Cause</b>  | <b>Solution</b>                         |
|----------------------------|--|---|
| Pump will not turn on      | Blown fuse   | Replace fuse                            |
|                            | Module not grounded properly on either Primary or Switched Harness | Check wiring & ground                   |
|                            | No power to pump   | Check connector between pump and module |
|                            | Internal relay failure   | Return to MPB for replacement           |
| Vacuum pump won't turn off | Vacuum leak in system  | Diagnose location of leak and repair    |
|                            | Internal switch failure  | Return to MPB for replacement           |

### **\*\*\*IMPORTANT NOTES – PLEASE READ BELOW\*\*\***

- ***As with any electrical component or electrical system, proper grounding of the installed components is not just recommended but absolutely necessary. In addition, the ground system in the vehicle is also very important to the proper operation of this vacuum pump system.***
- ***If the vacuum hose and brake booster are not connected to the module when testing the operation of the pump, the system will not have a large enough volume of vacuum present in the system to keep the check valve within the module properly seated. This will cause the pump to pulse every couple of seconds.***

If you have any questions or comments, please call Master Power Brakes at (888) 351-8781.

# MASTER POWER BRAKES VACUUM PUMP / BRACKET MOUNTING TEMPLATE

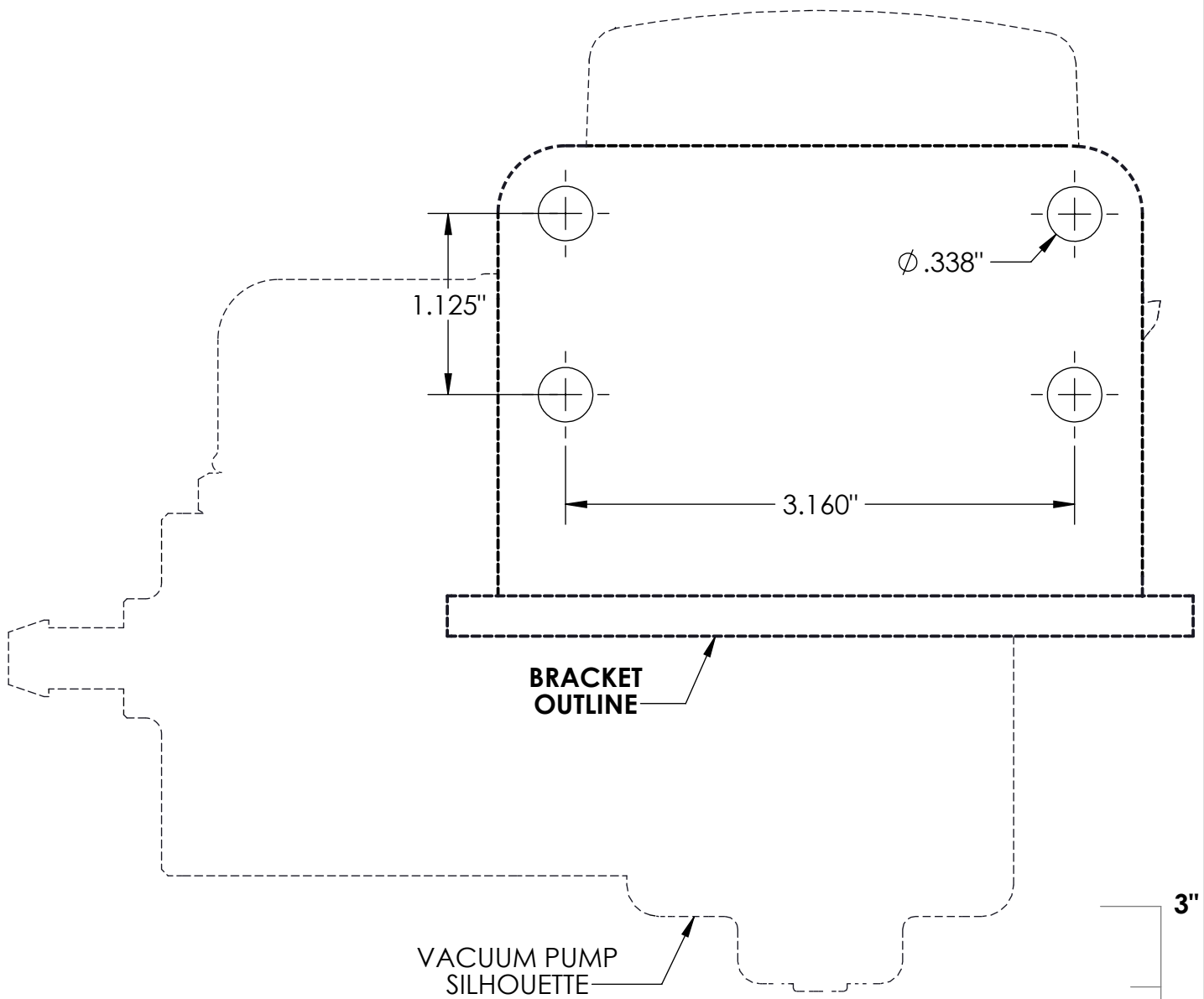

Use provided ruler to verify template has printed to scale

