



## Master Power Brakes Disc Brake Conversion Kit Falcon, Fairlane, Torino, and other Ford & Mercury Applications P/N: DB1509B/DB1509BHP & DB1510B/DB1510BHP



Thanks for your purchase of the Legend Series Disc Brake Conversion Kit. This front wheel kit is designed to fit the 1964-1973 Ford Falcon and Fairlane as well as other Ford & Mercury applications with a factory OE Drum Brake spindle. Everything is designed as a bolt-in installation that should be able to be completed with simple hand tools.  
**NOTE:** This system will fit most 14" wheels.

### Installation Notes:

- Please read all instructions before attempting the installation.
- Proper operation of your brakes is essential for your safety and the safety of others. Any brake service should be performed by a professional technician experienced in the installation of brake systems.
- Any installation requiring you to remove a wheel or gain access under the vehicle requires use of jack stands or a lift appropriate to the weight of the vehicle. In all cases, recommended ratings for jack stands should be at least 2-tons. If using a floor jack, be sure to use the appropriate wheel chocks.
- All installations require proper safety procedures and protective eyewear.
- A selection of hand tools sufficient to engage in the installation of these products is assumed and is the responsibility of the installer to have in his/her possession prior to beginning this installation. All installations, which require removal of hydraulic hoses and/or bleeding of the brakes, require appropriate fitting/line wrenches, as well as a safety catch can and protective eyewear. Other than these items, if unique or special tools are required they are listed in the section for that step.
- **ALWAYS CONFIRM WHEEL FITMENT PRIOR TO BEGINNING THE INSTALLATION OF ANY BRAKE SYSTEM!!** Returns will not be accepted for ANY installed part or assembly. Use great care to prevent cosmetic damage when performing wheel fit check!
- Before starting the installation, verify that all parts are included with the brake kit. If items are missing, notify Master Power Brakes immediately.
- Master Power Brakes recommends the use of a high quality DOT 3 or DOT 4 brake fluid. **ALL WARRANTY IS VOID IF DOT 5 FLUID IS USED.**

If you have any questions regarding installation, feel free to contact Master Power Brakes at (888) 351-8781 or through our website at [www.mpbrakes.com](http://www.mpbrakes.com).

Parts List	
Quantity	Description
1	Driver Side Caliper (Includes brake pads)
1	Passenger Side Caliper (Includes brake pads)
2	Rotors
1	Driver Side Caliper Mounting Bracket
1	Passenger Side Caliper Mounting Bracket
2	A2 Outer Wheel Bearing (DB1509B Only)
2	A6 Inner Wheel Bearing (DB1509B Only)
2	A12 Outer Wheel Bearing (DB1510B Only)
2	A13 Inner Wheel Bearing (DB1510B Only)
2	6815 Inner Grease Seal
1	Caliper Shim Kit
2	Brake Hose Kit (Includes: hoses, bolts, & washers)
6	3/8"-24 x 1 1/2" Grade 8 Hex Head Bolt
2	3/8"-24 x 2 1/2" Grade 8 Hex Head Bolt
8	3/8"-24 Nyloc Nut
4	7/16" Grade 8 Lock Washer
1	Spindle Nut Kit (Includes washer, castle nut and retainer)
2	Rotor Grease Cap

Replacement Parts	
Front Brake Pads	FMSI No: D11

## Installation:

1. With the vehicle properly supported, remove the front wheels and tires followed by the removal of the factory drum brakes. Remove the drum and hub assembly along with the shoes, hardware and backing plate along with the brake hoses.
2. Before installing the disc brake kit, inspect the spindles for any excessive wear or damage. If any is present, replace, replace the spindle(s) as necessary. If spindles are good clean all attachment points along with the spindle pin to insure proper installation of the new components.
3. Install the billet aluminum caliper mounting bracket onto the spindle. To install, use the provided (3) 3/8"-24 x 1 1/2" Grade 8 bolts and (1) 3/8"-24 X 2 1/2" Grade 8 bolt along with (4) 3/8"-24 Nyloc lock nuts. The longer of the bolts installs in the bottom hole closest to the steer arm. See Figures 1a and 1b below for reference. Torque the bolts to 45 ft/lbs.

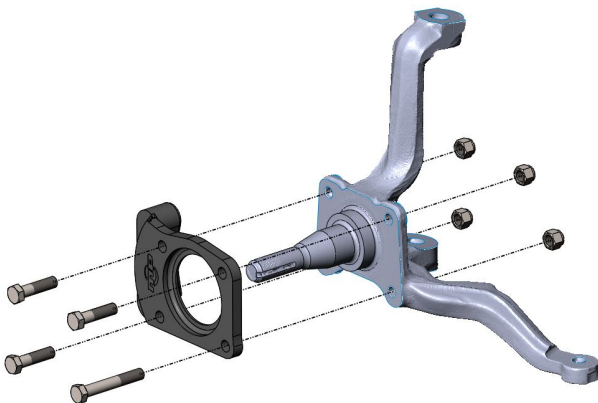

Figure 1a – Caliper Bracket Installation (Front)

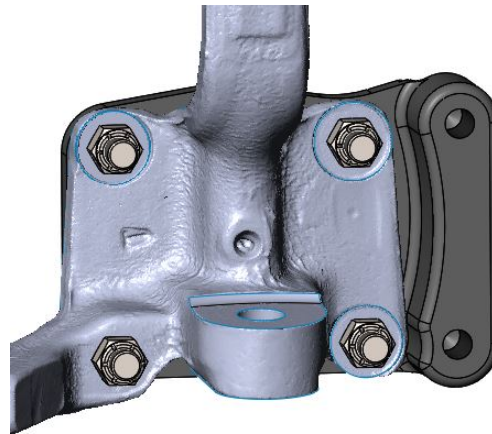

Figure 1b – Caliper Bracket Installed (Back View)

4. Before installing the wheel bearings into the rotors, it is recommended that the rotors be thoroughly cleaned with soap and water. Be sure to dry them after cleaning.
5. The wheel bearings can now be packed with a high quality wheel bearing grease available at your local parts store and the bearings can be installed in the rotors at this time. Once the inner bearing is installed, tap the inner seal in at this point. Figure 2 shows the bearing and seal being installed.

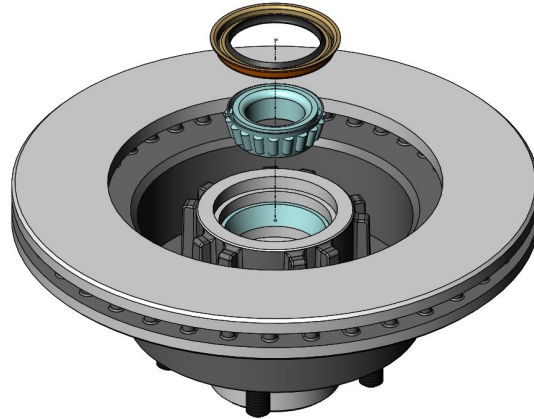

Figure 2 – Inner Wheel Bearing Installation

6. Slide the rotor onto the spindle. The inner wheel bearing and grease seal should be installed at this point. With the rotor fully pushed onto the spindle, install the outer wheel bearing followed by the keyed washer and the spindle nut. When tightening the spindle nut, tighten to 5-10 ft/lbs. Loosen the nut and tighten again using the same 5-10 ft/lbs. Do this a couple of times spinning the rotor to fully seat the wheel bearings onto the spindle. Loosen the nut a final time and re-tighten to move all play. Tighten approximately an additional 1/16<sup>th</sup> of a turn to give the appropriate pre-load and line up the cotter pin hole. Install the spindle nut retainer and the cotter pin to secure followed by the grease cap. See Figure 4 on next page for reference. **IMPORTANT:** If using slotted and drilled rotors, pay close attention to Figure 3 below for proper rotor placement on the driver or passenger side.

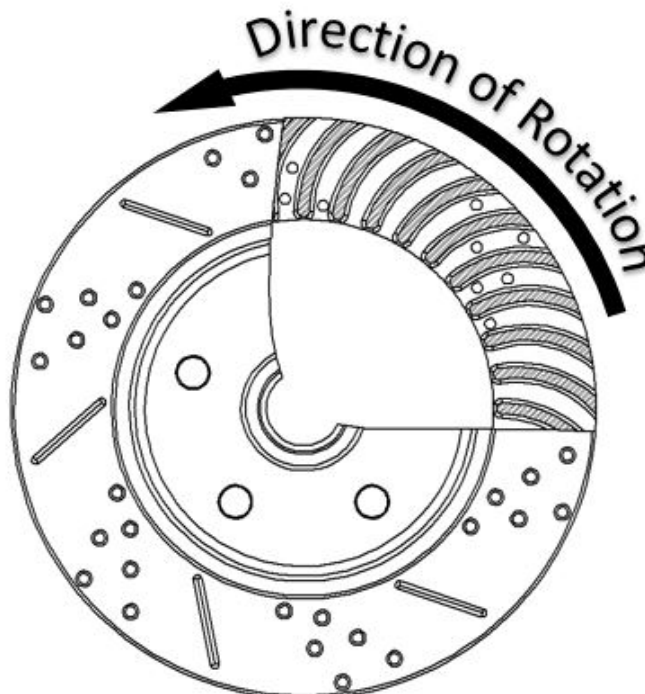

Figure 3 – Rotor Orientation

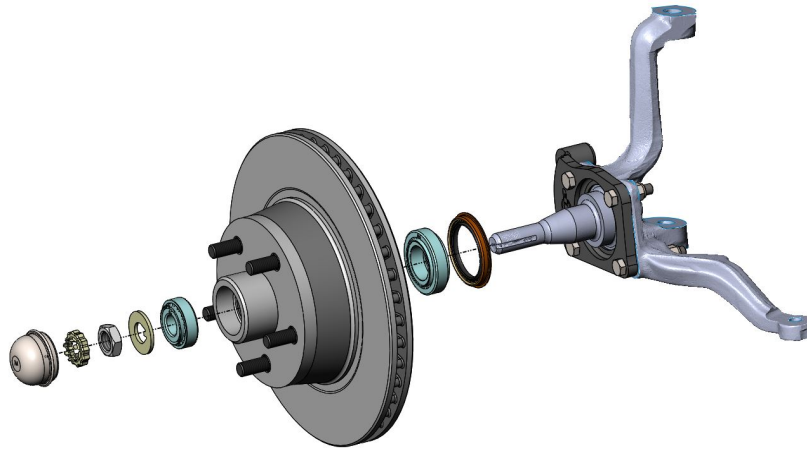

Figure 4 – Rotor Installation

7. Mount the caliper to the caliper mounting bracket. With the pads installed in the caliper, slide the caliper over the rotor and line up the mounting ears of the caliper with the holes in the caliper mounting bracket. Using the provided 7/16"-14 x 1 1/2" Grade 8 Hex Head Bolts and 7/16" Lock washers, tighten the bolts at this time but do not torque. **NOTE:** When installing the calipers, make sure the brake bleeders are pointing upward. See Figures 5a and 5b on the next page for reference.

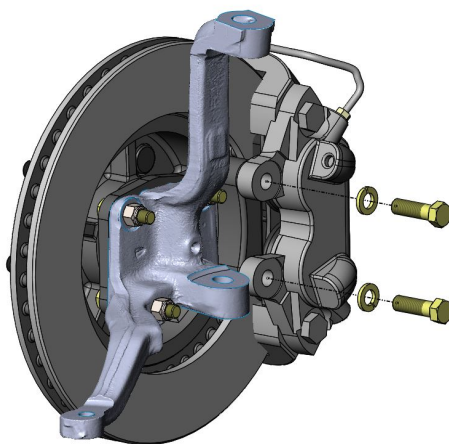

Figure 5a – Caliper Bolt Installation

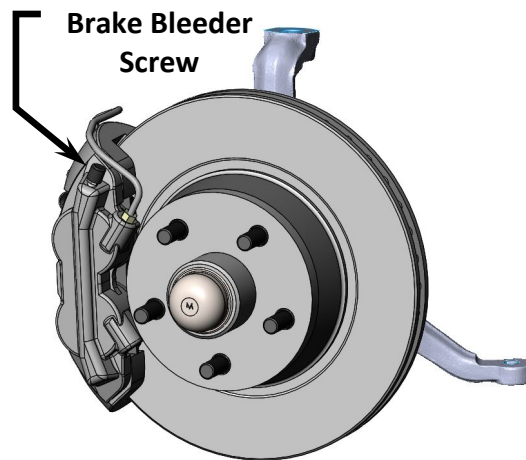

Figure 5b – Bleeder Screw Placement

8. With the caliper mounted, it is necessary to shim the caliper to center it over the rotor. A shim kit is supplied with the disc brake kit to accomplish this. Measure the gap from the rotor to caliper body at 4 points (top inside and outside and the bottom inside and outside). With all measurements taken, subtract the top inside measurement from the top outside measurement. Take that difference and divide by two to determine the shim required. For example, the inside measurement is .020" and the outside measurement is .050" leaving a difference of .030". Divide the difference by two leaving the necessary shim at .015". Do this procedure at both the top and bottom to determine appropriate shimming. It is possible for the top and bottom to require different thickness shims. If possible, set the gaps to within .005" of each other. This will keep the possibility of noise to a minimum. Follow the steps below for proper shimming of the calipers once the measurements have been taken:
  - a. Select the required shims from the shim kit provided.
  - b. Remove the caliper.
  - c. Place the shims between the caliper mounting ears and the aluminum bracket.
  - d. Install the appropriate shims one bolt at a time. Snug bolts at this time.
  - e. Reinstall the caliper and recheck the gap as described above. If necessary, add or remove shims.

**NOTE:** Shimming of the caliper is required due to variations in spindle manufacturing and wear at the bearing seat area of the inner bearing. Refer to Figure 6a on next page for measuring reference and Figure 6b for the location of the shims.

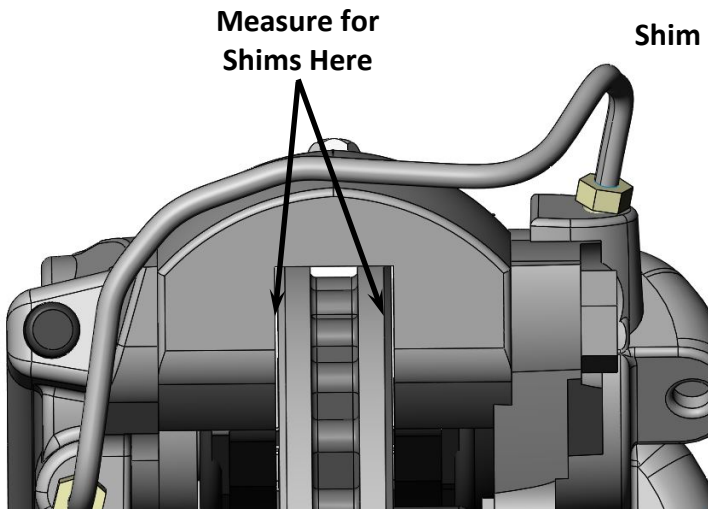

Figure 6a – Measure Location

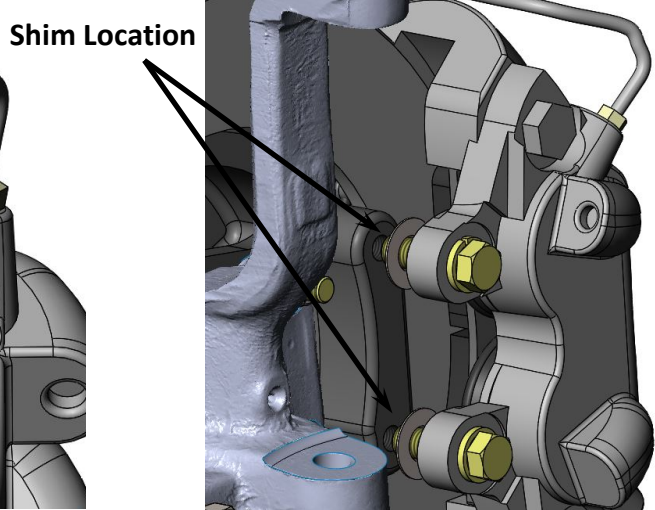

Figure 6b – Shim Location

9. Once proper shimming has been done, torque the caliper mounting bolts to the bracket to 60 ft/lbs.
10. Install the brake hoses onto the caliper and attach to the original plumbing on the vehicle. **NOTE:** Be sure the copper crush washer has been installed on the brake hose to prevent leaks before installing. Figure 7 below shows the installed brake hose at the caliper.

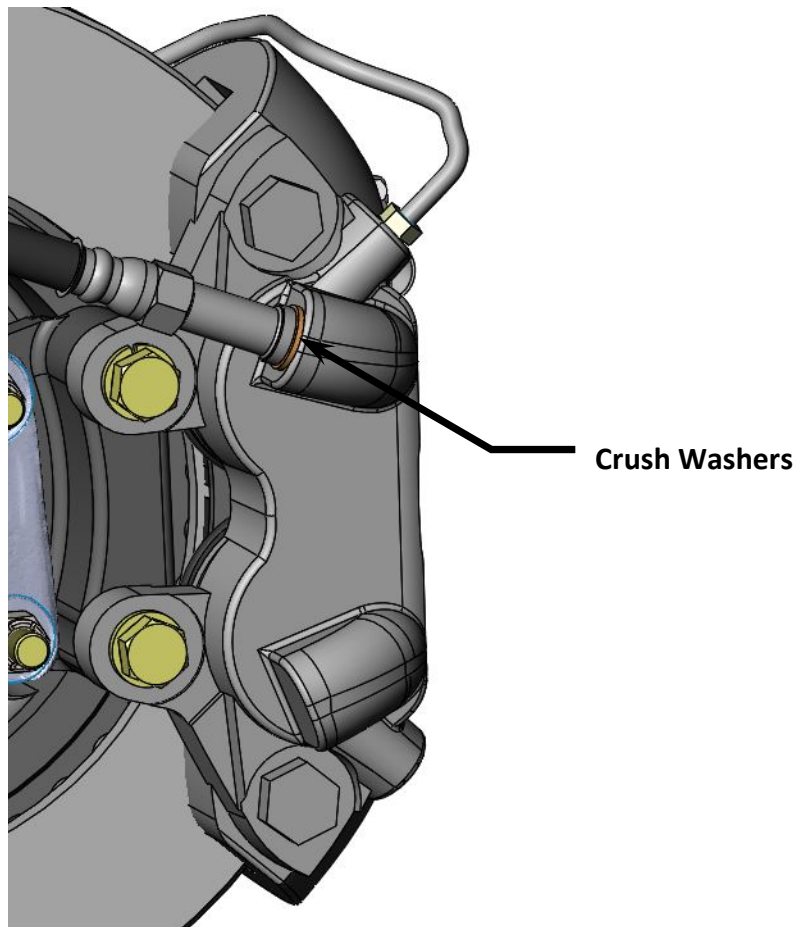

Figure 7 – Brake Hose Installed

11. Once the master cylinder has been properly bench bled and then installed on the vehicle, the remaining brake system can be bled to remove all of the air from the system. **REMEMBER:** Master Power Brakes requires the use of either DOT 3 or DOT 4 brake fluid and recommends the use of Pentosin Super Dot 4 fluid as seen below in Figure 8. Any warranty is void if DOT 5 fluid is used.



Figure 8 – Pentosin Super Dot 4

12. The installation is complete.

If you have any questions or comments, please call Master Power Brakes at (888) 351-8781.