



Master Power Brakes

Power Brake Booster Conversion Kit

1966-1972 B-Body Mopar & 1970-1974 E-Body Mopar Vehicles w/OE Power Brakes

P/N: BM13403-1 & BM13403-2 and
BM13503-1 & BM13503-2

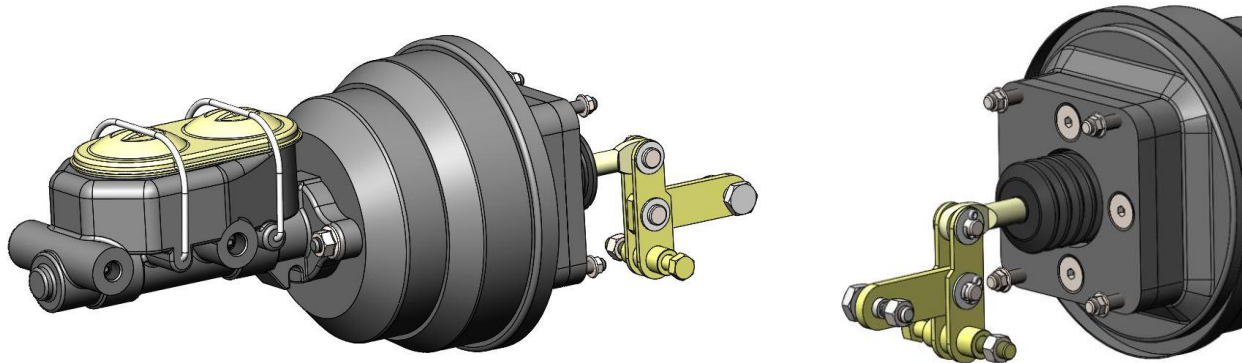

Thank you for your purchase of our Power Brake Booster Conversion Kit for the 1966-1972 Mopar B-Body and the 1970-1974 Mopar E-Body vehicles when equipped with OE Power Brakes. This system is designed using a billet aluminum adapter plate for vehicles originally equipped with Power Brakes. This is a complete bolt-in solution to replace your existing factory power booster. Depending on application, it will include either a 1" or a 1-1/8" bore master cylinder and is designed to work with both manual and automatic transmission applications.

Installation Notes:

- Please read all instructions before attempting the installation.
- Proper operation of your brakes is essential for your safety and the safety of others. Any brake service should be performed by a professional technician experienced in the installation of brake systems.
- Any installation requiring you to remove a wheel or gain access under the vehicle requires use of jack stands or a lift appropriate to the weight of the vehicle. In all cases, recommended ratings for jack stands should be at least 2-tons. If using a floor jack, be sure to use the appropriate wheel chocks.
- All installations require proper safety procedures and protective eyewear.
- A selection of hand tools sufficient to engage in the installation of these products is assumed and is the responsibility of the installer to have in his/her possession prior to beginning this installation. All installations, which require removal of hydraulic hoses and/or bleeding of the brakes, require appropriate fitting/line wrenches, as well as a safety catch can and protective eyewear. Other than these items, if unique or special tools are required they are listed in the section for that step.
- **ALWAYS CONFIRM WHEEL FITMENT PRIOR TO BEGINNING THE INSTALLATION OF ANY BRAKE SYSTEM!!** Returns will not be accepted for ANY installed part or assembly. Use great care to prevent cosmetic damage when performing wheel fit check!
- Before starting the installation, verify that all parts are included with the brake kit. If items are missing, notify Master Power Brakes immediately.
- Master Power Brakes recommends the use of a high quality DOT 3 or DOT 4 brake fluid. **ALL WARRANTY IS VOID IF DOT 5 FLUID IS USED.**

If you have any questions regarding installation, feel free to contact Master Power Brakes at (888) 351-8781 or through our website at www.mpbrakes.com.

Parts List	
Quantity	Description
1	8" Dual Diaphragm Brake Booster
1	1" or 1-1/8" Bore Master Cylinder
1	Pushrod Pivot Assembly
1	Inner Billet Aluminum Adapter Plate (Pre-assembled on booster)
1	Outer Billet Aluminum Adapter Plate (Pre-assembled on booster)
4	5/16"-18 Flanged Hex Nuts (Threaded on booster studs)
1	Vacuum Hose Kit (Includes Syringe Bleeder, 3/8"-NPT Fitting and Vacuum Hose)

1. Remove the existing brake apply system from the vehicle.
 - a. Disconnect the push rod under the dash from the brake pedal.
 - b. Remove the brake lines from the master cylinder.
 - c. Unbolt the stock booster/master cylinder from the firewall and remove it as well as the stock pushrod from the vehicle.
 - d. Clean the mounting area in preparation of the new brake booster assembly.
2. Test fit the booster assembly to the firewall to verify proper clearance between the engine along with any support braces or other accessories within the engine compartment.
3. After test fitting, remove the assembly from the vehicle and separate the master cylinder from the booster for bench bleeding. There are two methods that can be used for bench bleeding the master cylinder. They are listed below:

Syringe Bleeding (Tools provided in system)

1. Position the master cylinder in a vise clamped by a mounting ear.
2. Pour brake fluid into each chamber of the master cylinder to between $\frac{1}{4}$ and $\frac{1}{2}$ full.
3. Using the syringe with the rubber tip attached, fill the syringe using the fluid in the master cylinder chamber. Fill the syringe to about half full.
4. Press the rubber tip to the port on the master cylinder. Holding the syringe firm against the master cylinder, inject the fluid into the master cylinder. The fluid as it flows into the master cylinder will turn from bubbles in the chamber to a steady stream of fluid.
5. When pulling the syringe away from the master cylinder, fluid will drip from the port so have a damp towel handy to wipe off the master cylinder especially if you have painted it.
6. Plug the port with the provided plastic plugs from the Vacuum Hose Kit included with the system.
7. Once a steady stream has been detected, empty the syringe of fluid and then repeat steps 3 through 6 from above for the remaining port.

Hose Bleeding (Tools not provided in system)

1. Position the master cylinder in a vise clamped by a mounting ear.
2. Pour brake fluid into each chamber of the master cylinder to between $\frac{1}{4}$ and $\frac{1}{2}$ full.
3. Thread the plastic fittings into each port on the master cylinder and attach the hoses to the fittings. Route the hoses into the chambers on the master cylinder and secure. Make sure the hoses are submerged into the fluid.
4. Using a large Phillips screwdriver inserted into the end of the master cylinder piston, press the piston slowly into the master cylinder and release. Repeat until there is no air coming from the hoses.

5. Remove the hoses and fittings from the master cylinder. When removing the fittings from the master cylinder, fluid will drip from the port so have a damp towel handy to wipe off the master cylinder especially if you have painted it.
6. Plug each port with the provided plugs from the Vacuum Hose Kit included with the system.
4. Reinstall the master cylinder back onto the brake booster and install the unit to the firewall. Using the provided 5/16"-18 Flanged Hex Nuts, tighten the hardware.
5. Install the provided pivot assembly in the factory location on the firewall and install the pushrod to the brake pedal. Some adjustment may be necessary for proper brake lamp switch operation and pedal position. **NOTE:** When adjusting the pushrod, be sure to leave adequate free play at the top of the pedal to avoid any unnecessary application of the brakes.
6. Using the provided fittings, install the vacuum tee in the engine. The best source for obtaining vacuum from the engine is to install the fitting in an intake runner in the intake manifold. **NOTE:** The provided fitting is a 3/8"-NPT fitting. For proper operation, find a location that does not require adapting to a smaller fitting and thread size if possible. Connect the provided hose from the fitting to the check valve on the booster.

IMPORTANT: For proper operation of the brake booster, the engine must produce 18" of vacuum. Anything under 18" vacuum will produce a firm pedal.

7. Route the brake lines from the master cylinder to whatever valve is being used in the system. Refer to Figure 1 below for proper orientation of the brake lines to the master cylinder.

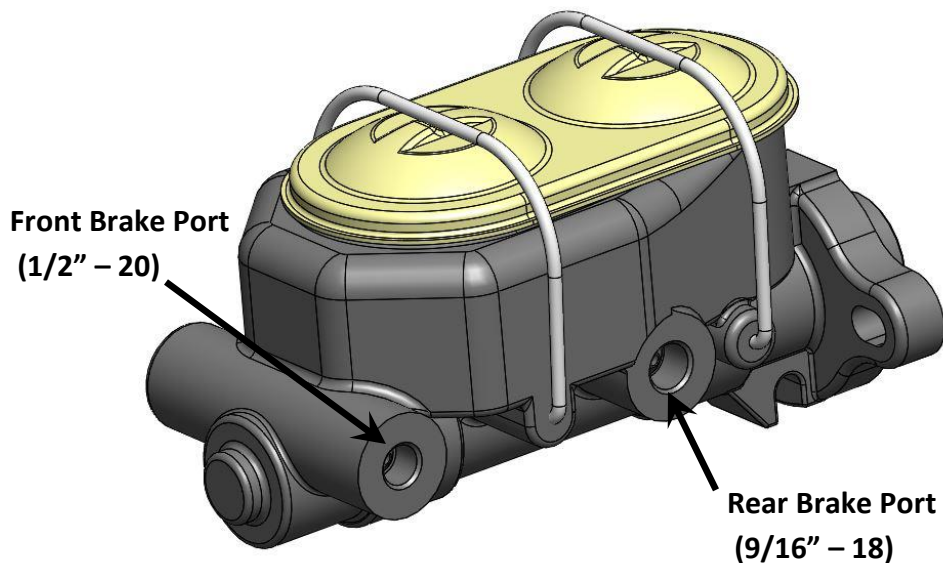

Figure 1 - Brake Line Orientation

8. Bleed the remaining portion of the brakes system. **REMEMBER:** Use only DOT 3 or DOT 4 fluid in your brakes system. Anything else will void the warranty of the master cylinder.
9. The installation of the Power Brake Booster Conversion Kit is now complete.

If you have any questions or comments, please call Master Power at (888) 351-8781.