

# PLEASE READ THIS FIRST!

Take time to read all of the literature that came with your brake kit and to check the provided list of parts against what you received to be sure that you are fully prepared to complete your brake changeover!

Your kit was designed to make the process of changing your brake parts as simple and painless as possible. However, in some cases, you will find it necessary to make minor changes to your car, so be prepared to do that. Also, please allow enough time to complete the job properly. It is not unusual for you to encounter something unforeseen and have to make a modification or ask a question.

We are constantly updating our literature to reduce and help you answer your own questions. You can find technical help in the packet we provide with your kit or on the website at: ([www.911brakes.com](http://www.911brakes.com)). You may also call our technical department Monday - Friday between the hours of 8:00 am & 5:00 pm, Eastern standard time at: (888-533-1199). Be advised that you may be asked to leave your name, phone number, account information, and the description of the problem you are experiencing. If this happens then please leave this information, so when your call is returned, our tech department will be fully prepared to deal with your problem. This will keep time on the phone to a minimum, which gets you back to your task at hand as soon as possible and allows us to help others.

*Once again,  
Thanks for choosing Master Power Brakes!*

## NOTE

Proper operation of your brakes is essential for your safety and the safety of others, so any brake service should be performed by persons experienced in the installation and proper operation of brake systems. It is the responsibility of the person installing any brake component or kit to determine the suitability of the component or kit for that particular application.

## INSTALLATION INSTRUCTIONS

### INCLUDED COMPONENTS

Your power brake conversion kit will contain the following components:

1. 8" dual diaphragm power booster
2. Master cylinder
3. Hanging pedal bracket
4. Pedal arm
5. Booster to pedal linkage
6. Under dash support strap
7. Firewall gasket

**NOTE: A DISC / DRUM BRAKING SYSTEM WILL REQUIRE THE USE OF A COMBINATION VALVE FOR PROPER SYSTEM BALANCE.**

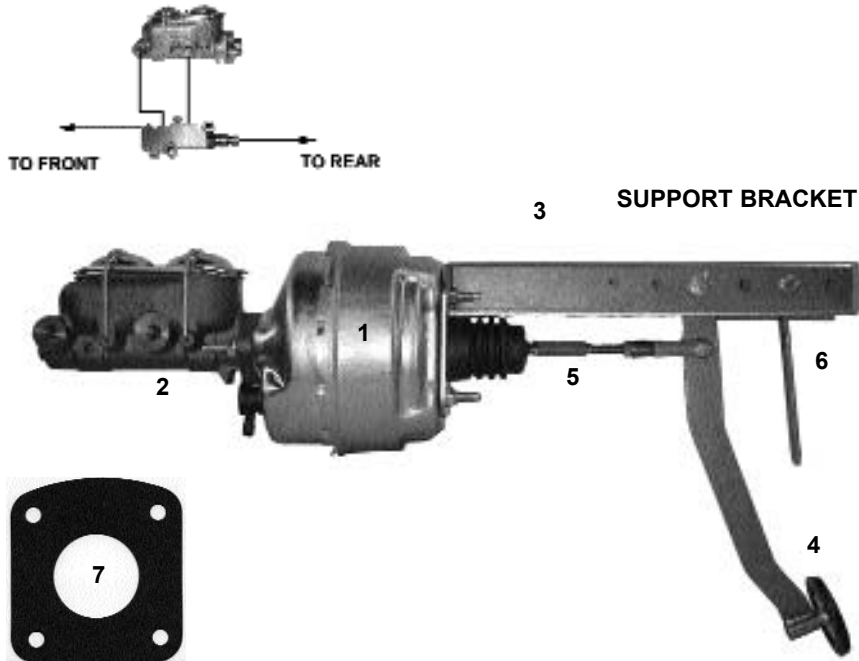

### INSTALLATION

1. Using the supplied template gasket for position of the booster on the firewall make sure that you have sufficient clearance for the booster. Pick a location that lines up with a proper brake pedal location.
2. Using the template gasket mark the firewall for drilling the center hole and the four booster mounting holes. The center hole is 2 1/2" diameter and the mounting holes are 3/8".
3. Measure the length of the pedal channel needed under the dash and cut off any excess.
4. Install the support bracket into position under the dash and attach the booster to the outside of the firewall using the 4 mounting studs and the supplied 3 MM nuts.
5. Mount the under dash support strap to the pedal support. Bend the support strap to conform to the dash as needed. Drill a 1/4" hole in the dash for attaching the strap.
6. Install the pedal on the pedal support using the 3/8 x 2 3/4" bolt Do not use a nut at this time. Check to be sure that this is where you want the pedal located. If the position is correct install the lock nut just enough to engage the nylon locking portion of the nut and have enough free play so the pedal will not bind.
7. Measure the distance between the booster push rod and the attachment hole in the swing pedal.
8. Pre assemble the push rod and forked clevis to the approximate measured length.
9. Screw the female end of the extension rod onto the booster rod with a minimum of 1/2" thread engaged. Secure the locknut to the push rod.
10. Adjust the clevis to fit the pedal. Note: at this time you may adjust your correct pedal height.
11. Mount the master to the booster. Check the pedal travel to be sure that the pedal will bottom out the master cylinder before the pedal touches the floor. You should be 1 1/2" off the floor.
12. Remove the master cylinder and bench bleed it.
13. Bleed the entire braking system using the included instructions.
14. Test drive the vehicle in a safe area before using. If pedal is spongy re bleed system.

# PA1200K PARTS LIST PEDAL, UNIVERSAL SWING

MASTER POWER BRAKES 888-533-1199

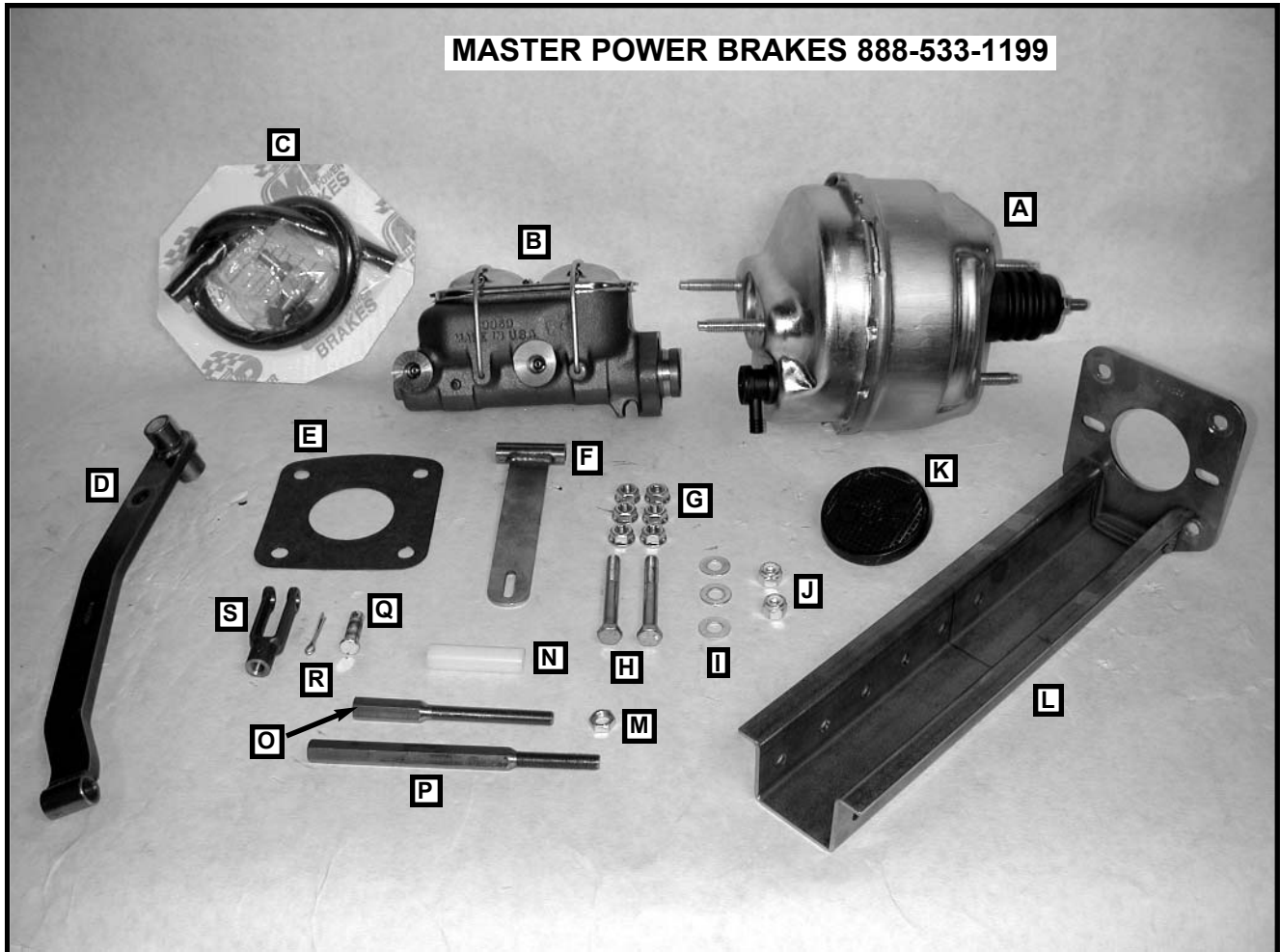

## PARTS LIST

Revised 11/4/03

- A) (1) BS8001 BOOSTER, 8" DUAL DIA.
- B) (1) MC390545P MASTER, 1-1/8 BORE 4WD, CORVETTE STYLE MASTER
- C) (1) HS4001K HOSE KIT, VACUUM
  - (1) AC2002 BLEEDER KIT, USED IN DUAL MASTER CYL. APPL.
  - (1) HS4001-2 VACUUM HOSE, 2FT PER KIT
  - (1) HW40066 FITTING, MALE ELBOW, 3/8 O.D. TUBE, 3/8 PIPE VAC. HOSE
  - (1) HW413-66 FITTING, MALE INVERTED, 3/8 HOSE I.D., 3/8 MANIFOLD VAC. HOSE
- D) (1) PA1200 PEDAL ARM
- E) (1) GK9-8206 GASKET, BOOSTER, 65-70 CHEVY
- F) (1) PA1200 UNDER DASH SUPPORT BRACKET
- G) (6) 37CNWFZ 3/8-16, WHIZ FLANGE ZINC
- H) (2) 37C275HCS8Y BOLT, 3/8-16 X 2 3/4 HCS
- I) (3) 37NSAEFWZ FLAT WASHER, 3/8
- J) (2) 37CNNEZ NUT, 3/8-16 NYLOCK ZINC
- K) (1) HW15093 PEDAL PAD, UNDER FLOOR AND SWING PEDALS
- L) (1) PA1200 PEDAL SUPPORT BRACKET
- M) (1) 37FNFJOZ NUT, 3/8-24 HEX FINISH J-NUT ZINC
- N) (1) BU1521 BUSHING, NYLON, PEDAL MUSTANG
- O) (1) PRBL3 PUSH ROD 3" FOR BOOSTER
- P) (1) PRBL7 PUSH ROD 7" FOR BOOSTER
- Q) (1) 37N112PCLZ PIN, 3/8 X 1 1/8 CLEVIS
- R) (1) 12R100PCOZ COTTER PIN, 1/8 X 1"
- S) (1) HW3719 CLEVIS PIN/ CAST IRON 3/8 X 24 THREAD/ FEMALE