



WARNING

Proper operation of your brakes is essential for your safety and the safety of others. Any brake service should be performed ONLY by persons experienced in the installation and proper operation of brake systems. It is the responsibility of the person installing any brake component or kit to determine the suitability of the component or kit for the particular application. After installation and before operating your vehicle, be sure to test the function of the brakes under controlled conditions.

DO NOT DRIVE WITH UNTESTED BRAKES!

FOR TECHNICAL ASSISTANCE CALL:

888-533-1199

MONDAY - FRIDAY

8:00 AM TO 5:00 PM EST

IMPORTANT

Take time to read all the literature that came with this kit. Check the provided list of parts against what you received to ensure all parts are present. While this kit was designed to make the process of changing brake parts as simple as possible. **NOTE: WITH SOME KITS IT MAY BE NECESSARY TO MAKE MINOR CHANGES TO YOUR CAR!**

**READ ALL WARRANTY DISCLAIMERS AND RETURN POLICIES
INCLUDED IN THIS KIT PRIOR TO INSTALLATION!**

MASTER POWER BRAKES

110 CROSSLAKE PARK RD. MOORESVILLE, N.C. 28117

www.mpbrakes.com

DB1755D DB1756D SERIES INSTALLATION INSTRUCTIONS DROP SPINDLE DISC KITS

NOTE: THE INSTALLATION OF DISC BRAKES WILL REQUIRE THE USE OF 15" WHEELS. ANY ATTEMPT TO INSTALL DISC BRAKES WITH A 14" WHEEL WILL BE THE CUSTOMERS RESPONSIBILITY.

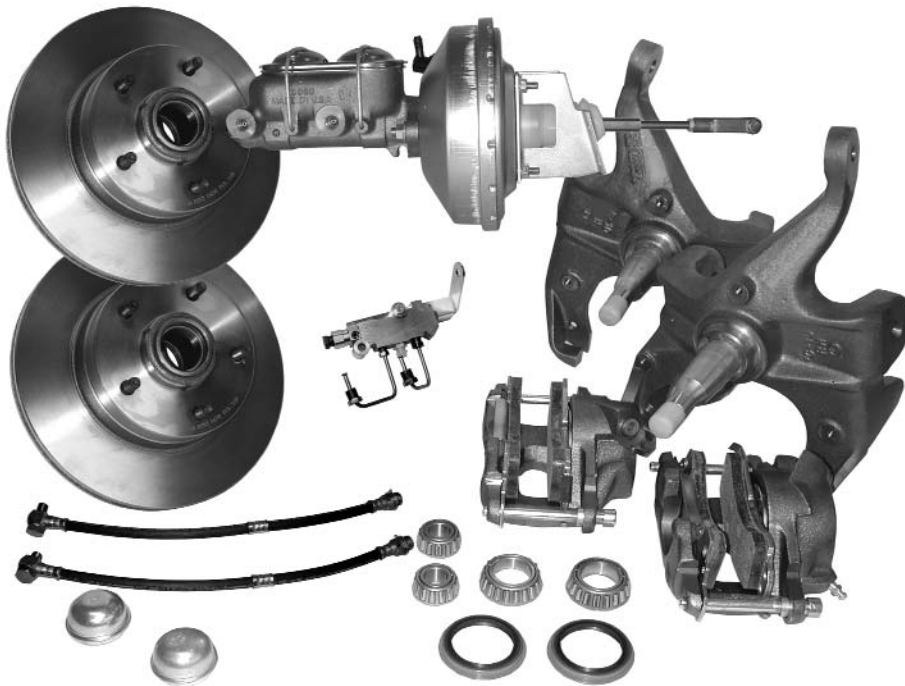

INSTALLATION INSTRUCTIONS

INCLUDED COMPONENTS

Your disc brake conversion kit may contain the following components:

1. Power booster with vacuum hose and intake manifold fitting.
2. Master cylinder
3. Combination valve kit
4. Drop spindles with integral caliper bracket
5. Calipers with pads
6. Rotors
7. Bearings, seals and dust caps
8. Caliper hoses

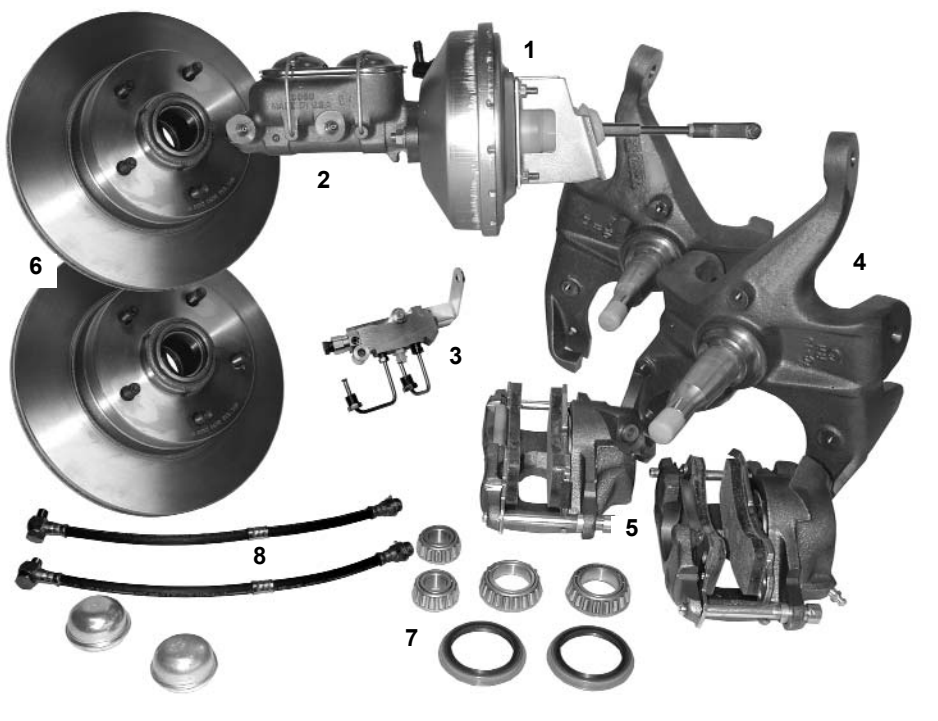

INSTALLATION

Installation of the disc brake kit will require the use of the following tools:

3/8" ratchet drive set
Box end wrench set
Pliers
Line flaring tool

Mallet
Ball joint fork
Screwdriver
Line bending tool

Flare wrench set
Drum brake tool
Snips

Always refer to the vehicle owners manual for the correct torque specifications when installing this kit

1. If you are performing the installation with a jack, be sure that the parking brake is set and that the rear wheels are chocked. Support the front of the vehicle with jack stands. Never work on sloping ground.
2. If you are using a lift, raise the vehicle to a comfortable working height.
3. Remove the front wheels.
4. At this point, be sure to place the proper support under the lower control arm. **Failure to do so will allow the coil spring to blow out when the spindle is removed which could result in serious injury and damage to the vehicle.**
5. Utilizing a mallet and screwdriver, remove the brake hose clip at the frame bracket by tapping it loose. Disconnect the brake hose from the hard line using the appropriate flare wrenches.
6. Locate the ball joint at the tie rod end and the steering arm. Remove the cotter pin and loosen the ball joint nut approximately 1/2 off. This allows for a controlled , separation. Place the ball joint fork between the steering arm and the ball joint. Strike the fork with a mallet until the steering are and ball joint separate. Remove the ball joint nut.
7. Repeat the process described in step 6 for the upper ball joint at the spindle. Place the ball joint fork between the spindle and the ball joint and remove the ball joint.
8. Slowly lower the support and remove the drum brake assembly as a unit.
9. Inspect the ball joints for signs of excessive wear and check to see if the rubber boot is torn. If the ball joint wobbles excessively or is worn, now is the time for replacement. Clean the ball joints with a rag.
10. Place the disc brake spindle onto the lower ball joint. Torque the nut to the specification in the owners manual. Insert the cotter pin and bend it.
11. Raise the control arm support and repeat step 10 for the upper ball joint. Remember to use the torque specification in the owners manual.
12. The caliper bracket is located on the spindle so that the caliper will be mounted toward the rear of the vehicle.
13. Attach the steering arm to the tie rod. Torque the nut to the recommended specification. Install the cotter pin and bend it.
14. Check the fit of the inner and outer bearing on the spindle. If the fit is too tight, lightly sand the spindle with emery cloth until the bearings slide on easily.

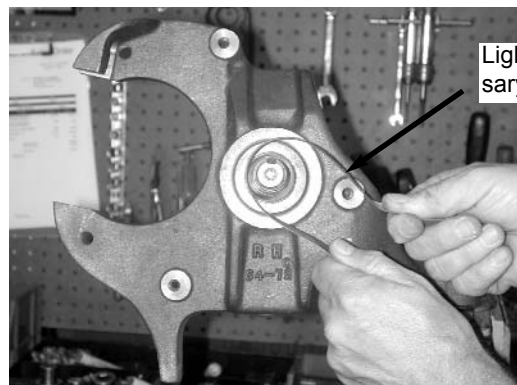

Lightly sand as necessary for inner bearing fit

15. **Grease the inner and outer bearing** by "packing" grease between the rollers and coating the inside and out side diameters. **Be sure to use a good high temperature bearing grease.**

16. Grease the inner and outer race on the inside of the rotor. Install the inner bearing into the rotor. Lightly tap the grease seal into place with a mallet until it is seated. **Clean the rotor before installation with brake cleaner followed by soap and water.**

Install the greased inner bearing into the rotor

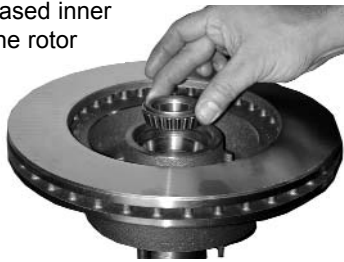

Install the grease seal into the rotor



17. Grease the spindle where the bearings fit. Install the rotor onto the spindle followed by the outer bearing, the keyed washer and spindle nut. Tighten the spindle nut to the specified torque and insert the cotter pin. Bend the cotter pin, snip off the excess, and install the dust cap, by tapping a socket that fits on the cap edge, or by tapping a screwdriver on the edge of the cap. Spin the rotor and check to be sure that it rotates smoothly and there is no wobble. **Clean the rotor.**



Mount the rotor with the installed inner bearing onto the rotor

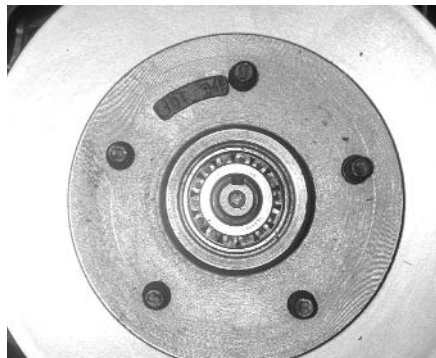

Install the greased outer bearing

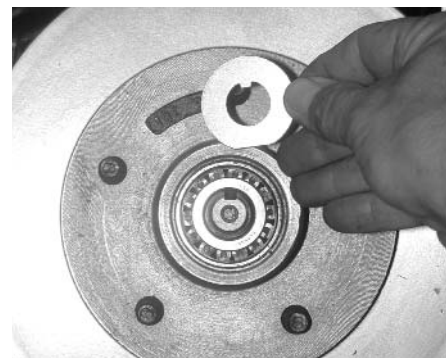

Install the keyed washer

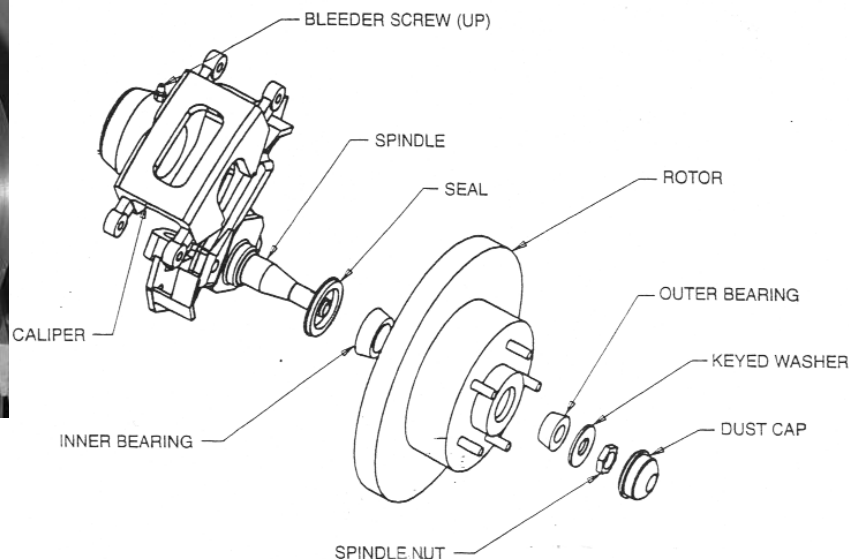
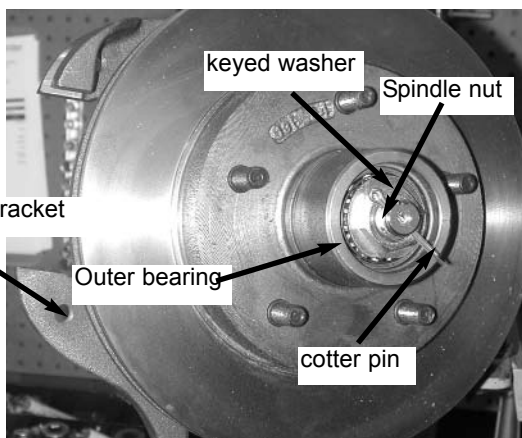

18. Install the loaded caliper onto the mounting bracket with the bleeder screw facing up. Insert the caliper mounting bolts and torque to the recommended specifications. Spin the rotor to be sure that it rotates smoothly. **The bleeder screw on the caliper must be on top.**

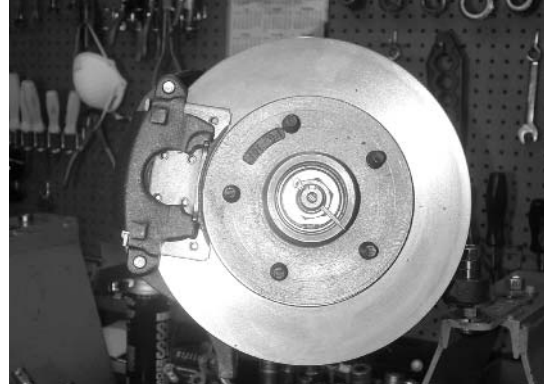
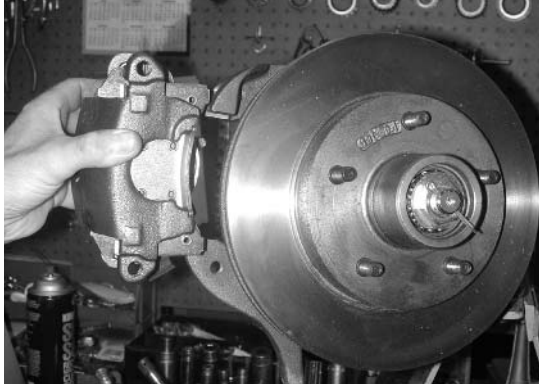

Bleeder screw must be on top of caliper

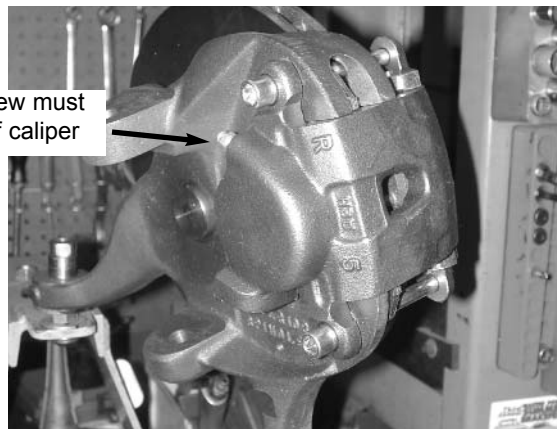

Caliper mounting bolts

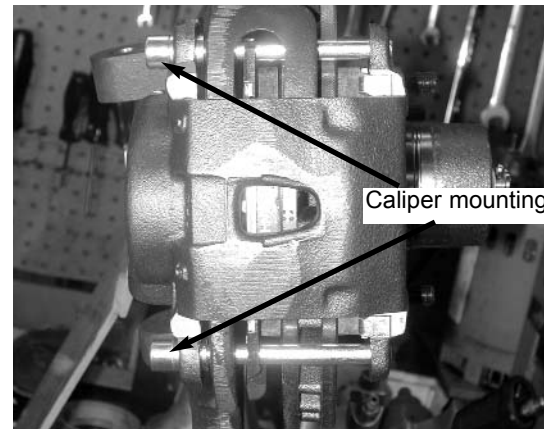

19. Install the hose onto the caliper. Be sure that the brass end of the hose is sandwiched between the two copper washers. The sequence must be: bolt - washer - hose fitting - washer - caliper. Tighten the bolt to the recommended specifications.
20. Using the flare wrenches, attach the other end of the hose to the hard line at the chassis. Tap the hose clip back into place with a mallet. Turn the steering assembly full right and left to be sure that the hose does not bind or twist.
21. Repeat this process for the other side and the disc portion of the conversion is complete.

MANUAL MASTER INSTALLATION:

1. Disconnect the master cylinder push rod from the brake pedal.
2. Remove the old master cylinder.
3. Using the two holes which line up with the larger hole, install the new master.
4. Attach the master cylinder push rod to the pedal with the supplied clevis attachment.
5. Place the proportioning valve bracket onto one of the nuts that holds the master and tighten.
6. Mount the valve to the bracket.
7. Run the two supplied pre-bent lines from the master to the valve.
8. Run hard line from the valve to the front and rear part of the braking system as per the valve diagram.

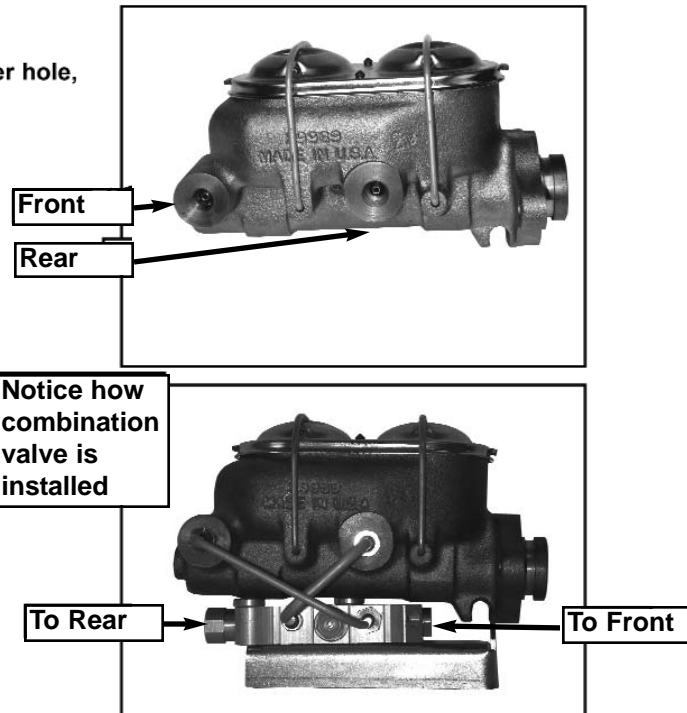

NOTE: When running lines to the front, you can plug one of the outlets on the valve (to front) and splice the one brake line to front calipers. You do not need to run two separate lines to the combination valve.

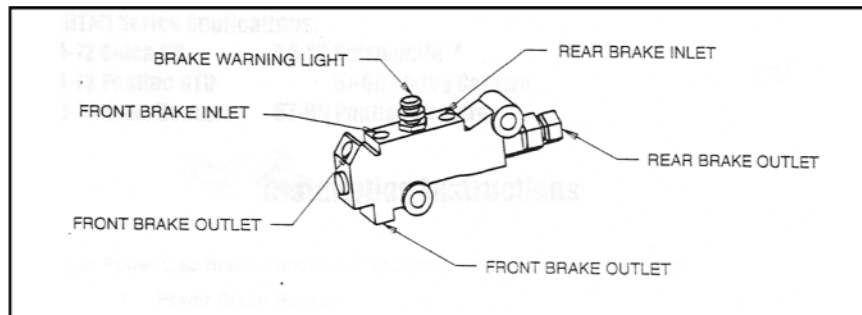

DB1755MD
DISC KIT, 63-70 TRUCK 2 1/2 DROPPED 5 LUG
PARTS LIST

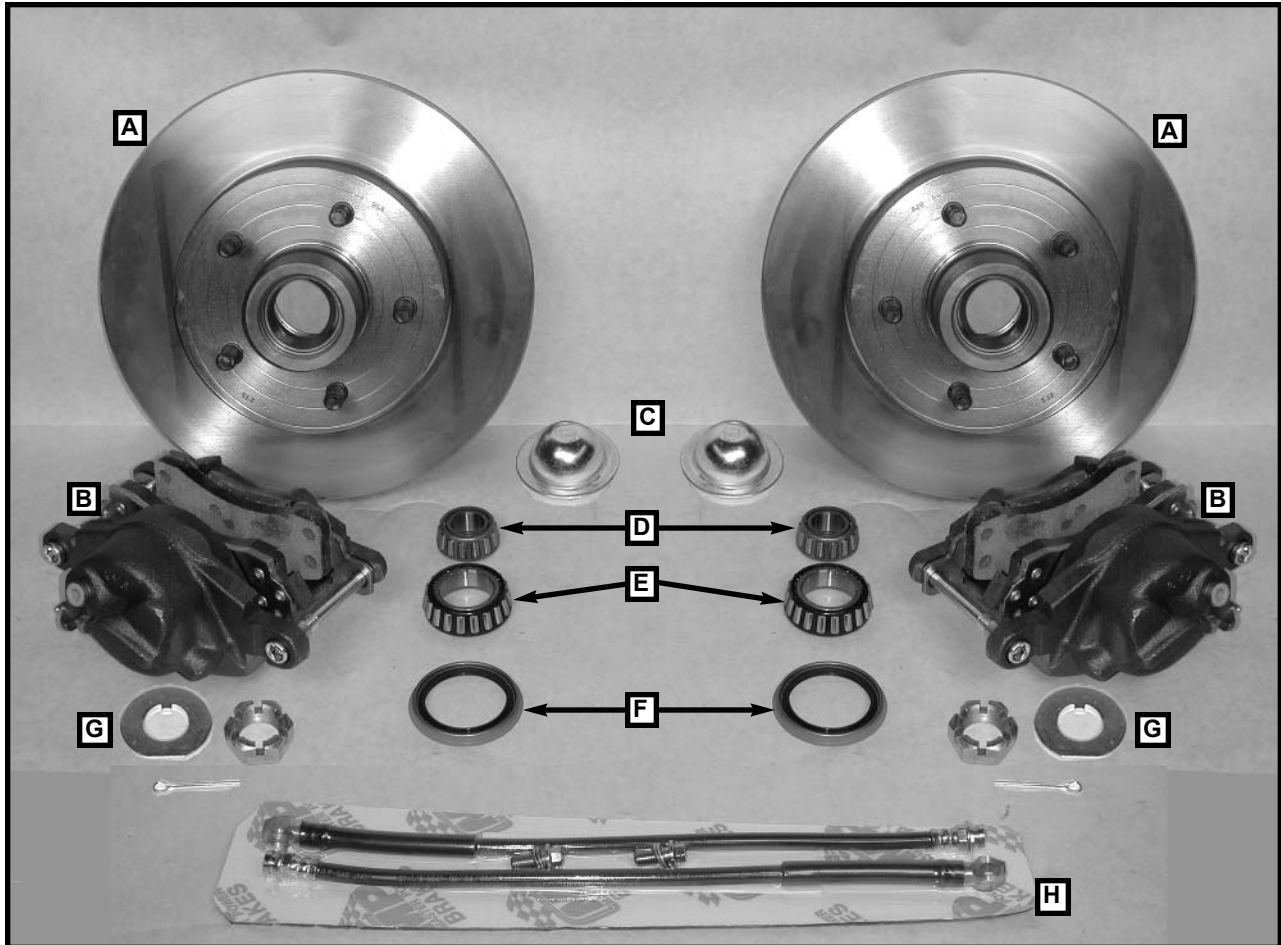

PARTS LIST

- A) (2) RT141043 ROTOR, GM TRUCK 5 LUG
- B) (2) CA404546 CALIPERS, 60-72 CHEVY TRUCK 5 OR 6 LUG PATTERN
- C) (2) HW4002 CAP, DUST, 53.2MM/2 3/32
- D) (2) HWA3 BEARING, OUTER
- E) (2) HWA5 BEARING, INNER
- F) (2) HW8871 SEAL, ROTOR
- G) (2) HW615005 WASHER, SPINDLE ORG. GM
- (2) HW615065 NUT, SPINDLE GM
- (2) 12R100PCOZ COTTER PIN, 1/8 X 1"
- H) (1) HS5157K HOSE KIT, 18" HOSES 10MM
- (2) HS5157 HOSE, 18" 10MM HOSE
- (4) HW21206 WASHER, COPPER USED FOR METRIC HOSE BOLTS
- (2) HW5155 10MM METRIC BOLT COURSE

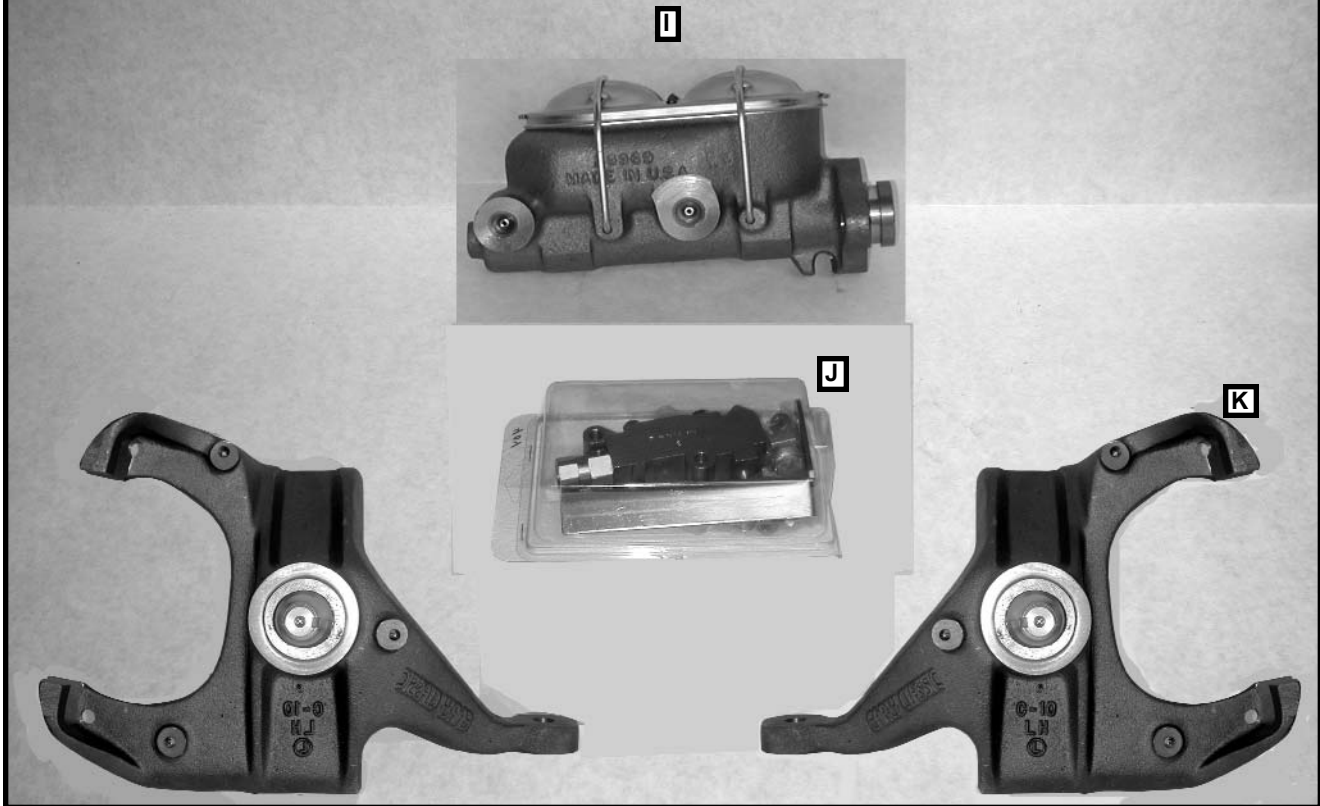

PARTS LIST (CONT.)

- I) (1) MC390360M MASTER CYLINDER, GM 1" BORE, 7/16" STROKE
DUAL RESERVOIR
- J) (1) VL3360K VALVE KIT, W/ FITTINGS
 - (1) 25C175HCS5Z 1/4 X .175 BOLT
 - (1) 25CNNEZ 1/4 COURSE NYLOCK NUT
 - (1) BR1261N BRACKET, VALVE, UNIVERSAL
 - (2) HW105-3 NUT, 3/16 TUBE 3/8-24 THD
 - (1) HW106-3 PLUG, 3/16"
 - (2) HW106-4 PLUG, INVERTED STEEL 1/4" O.D.
 - (1) HW115-37 NUT, 3/16 TUBE 7/16-24 THD RED
 - (1) HW115-38 NUT, 3/16 TUBE 1/2-20 THD BLACK
 - (1) HW115-39 NUT, 3/16 TUBE 9/16-18 THD OLIVE
 - (1) HW1709 PLUG, SWITCH, COMBO VALVE
 - (1) HW210-43 ADAPTOR, BRASS 7/16-3/8M
 - (2) HW300-3 COUPLER 3/16
 - (2) HW300-4 COUPLER 1/4
 - (2) HW300-5 COUPLER 1/2
 - (1) HW3359 PLUG, COMBO VALVE, 4 WHEEL DISC
 - (1) HW702-3 T-FITTING 3/16 X 3/16 X 3/16
 - (1) VL3350 VALVE, COMBO, DISC / DRUM
- K) (2) SP1755D DROPPED SPINDLE 63-70 2 1/2 DROP NEW

MASTER POWER BRAKES 888-533-1199