



WARNING

Proper operation of your brakes is essential for your safety and the safety of others. Any brake service should be performed ONLY by persons experienced in the installation and proper operation of brake systems. It is the responsibility of the person installing any brake component or kit to determine the suitability of the component or kit for the particular application. After installation and before operating your vehicle, be sure to test the function of the brakes under controlled conditions.

DO NOT DRIVE WITH UNTESTED BRAKES!

FOR TECHNICAL ASSISTANCE CALL:

888-533-1199

MONDAY - FRIDAY

8:00 AM TO 5:00 PM EST

IMPORTANT

Take time to read all the literature that came with this kit. Check the provided list of parts against what you received to ensure all parts are present. While this kit was designed to make the process of changing brake parts as simple as possible. **NOTE: WITH SOME KITS IT MAY BE NECESSARY TO MAKE MINOR CHANGES TO YOUR CAR!**

READ ALL WARRANTY DISCLAIMERS AND RETURN POLICIES INCLUDED IN THIS KIT PRIOR TO INSTALLATION!

MASTER POWER BRAKES

110 CROSSLAKE PARK RD. MOORESVILLE, N.C. 28117

www.mpbrakes.com

DB1754M6
DISC KIT, 60-62 TRUCK 6 LUG, MANUAL
PARTS LIST

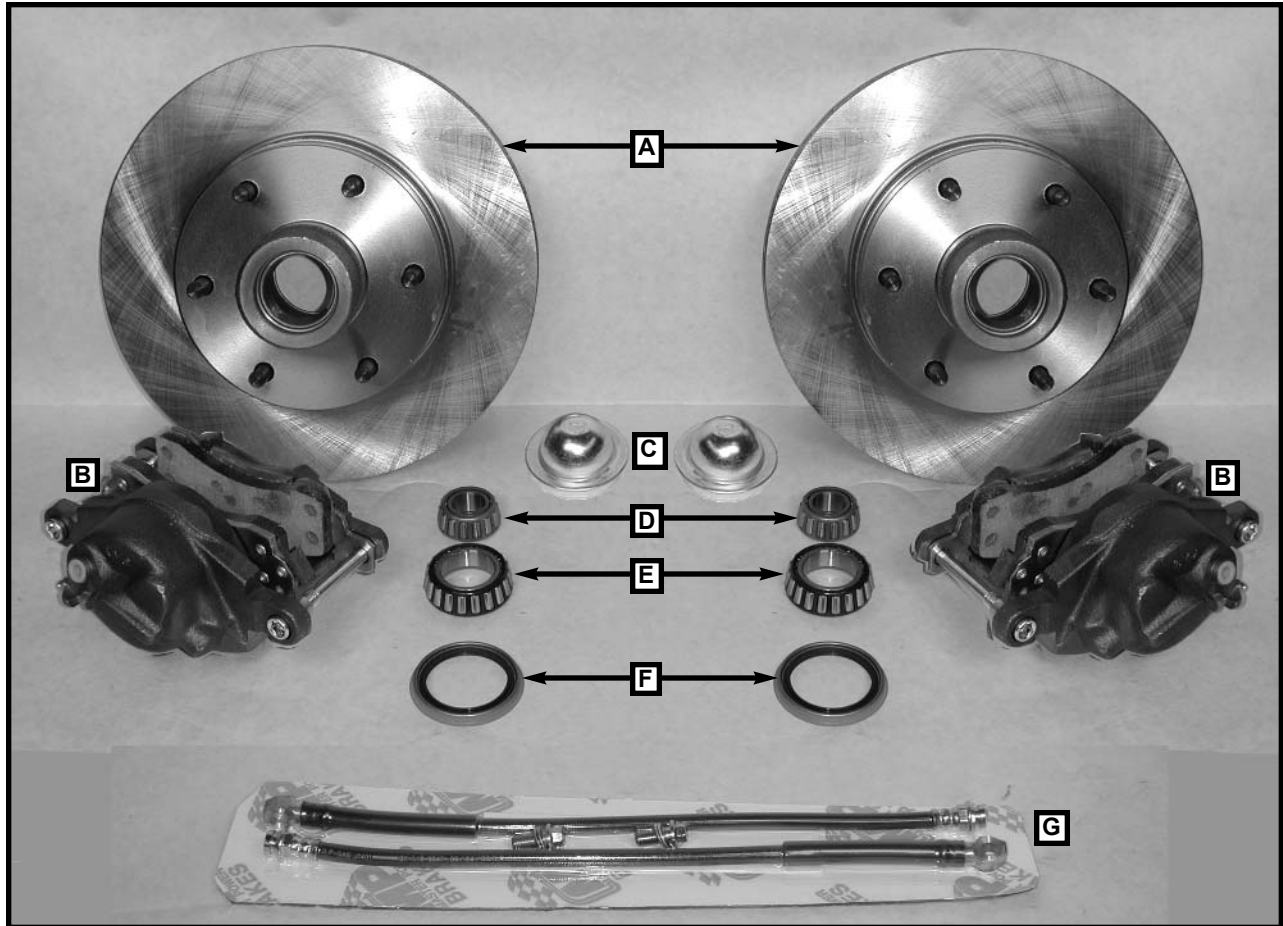

PARTS LIST

- A) (2) RTECE03-6070 6 LUG CHEVY TRUCK ROTORS
 60-70 MOD. ROTORS
 EARLY CLASSIC ENTERPRISE
- B) (2) CA404546 CALIPERS, 6072 CHEVY TRUCK 5 OR 6 LUG PATTERN
- C) (2) HW4002 CAP, DUST, 53.2 MM/2 3/32
- D) (2) HWA3 BEARING, OUTER
- E) (2) HWA5 BEARING, INNER
- F) (2) HW8871 SEAL, ROTOR
- G) (1) HS88520K HOSE KIT, FRONT, 69-77, 16" GM SING. PISTON CALIPER
 (2) HS88520 HOSE, F, 69-71 CAMARO, 16
 (4) HW21082 BOLT, HOSE 7/16 X 20 SHORT
 (2) HW4390 COPPER SEALING WASHER USED W/ 4039 & 4040 CALIPER
- H) (2) SP1755 63-70 TR SPINDLES STD. ← → (NOT SHOWN)

DB1754M6
CONTINUED

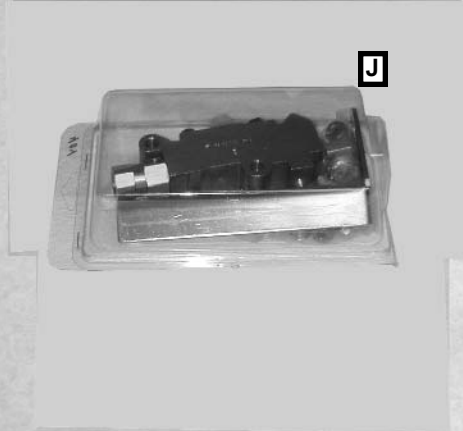
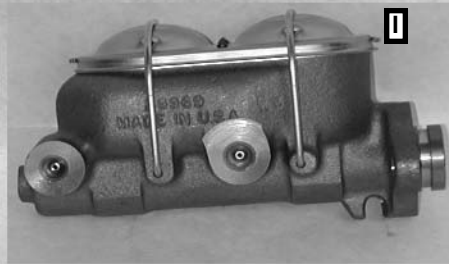

PARTS LIST (CONT.)

- I) (1) MC390360M MASTER CYLINDER, GM 1" BORE, 7/16" STROKE
DUAL RESERVOIR
- J) (1) VL3360K VALVE KIT, W/ FITTINGS
 - (1) 25C175HCS5Z 1/4 X .175 BOLT
 - (1) 25CNNEZ 1/4 COURSE NYLOCK NUT
 - (1) BR1261N BRACKET, VALVE, UNIVERSAL
 - (2) HW105-3 NUT, 3/16 TUBE 3/8-24 THD
 - (1) HW106-3 PLUG, 3/16"
 - (2) HW106-4 PLUG, INVERTED STEEL 1/4" O.D.
 - (1) HW115-37 NUT, 3/16 TUBE 7/16-24 THD RED
 - (1) HW115-38 NUT, 3/16 TUBE 1/2-20 THD BLACK
 - (1) HW115-39 NUT, 3/16 TUBE 9/16-18 THD OLIVE
 - (1) HW1709 PLUG, SWITCH, COMBO VALVE
 - (1) HW210-43 ADAPTOR, BRASS 7/16-3/8M
 - (2) HW300-3 COUPLER 3/16
 - (2) HW300-4 COUPLER 1/4
 - (2) HW300-5 COUPLER 1/2
 - (1) HW3359 PLUG, COMBO VALVE, 4 WHEEL DISC
 - (1) HW702-3 T-FITTING 3/16 X 3/16 X 3/16
 - (1) VL3350 VALVE, COMBO, DISC / DRUM
- L) (1) AC2002 BLEEDER KIT, USED IN DUAL MASTER CYLINDER APPLICATION ←→ (NOT SHOWN)

MASTER POWER BRAKES 888-533-1199



Series: DB1754

It's more than brakes...it's confidence!

1960-70 Chevy/GMC 1/2 Ton Pick-Up Truck Lowering Spindle/Disc Brake Conversion



Installation Instructions

The installation of this front brake kit is a complicated process, and should **not** be attempted by those who are mechanically inexperienced or unsure of their abilities. Failure to use high quality tools and jacks, safe practices, and proper safety equipment such as eye protection, could result in serious injury. We recommend this installation be performed by an experienced brake or suspension shop.

READ THESE INSTRUCTIONS BEFORE INSTALLATION

- 1.** Support truck by placing jack stands or lift arms under the truck's frame just behind the wheel well. Remove front wheels. Now is a good time to inspect brake assembly and suspension components for signs of wear and damage.
- 2.** Remove the front brake drum. With drain pan in place, loosen the steel brake line fitting at the brake hose. After draining all brake fluid, remove the retaining slip holding the brake hose.
- 3.** Remove the outer tie rod end cotter pin and loosen the castle unit. The tie rod ends and ball joints can be removed using several methods. A pickle fork can be used, but will damage the grease boots. A ball joint puller can be purchased or rented, or, you can strike the steering arm or spindle assembly with a heavy hammer. Caution: Always make sure to use protective eyewear.
- 4.** Unfasten the two steering arm retaining bolts and remove the steering arm. This will allow access to the lower ball joint. Remove the upper and lower ball joint cotter pins and loosen the castle nuts. Use the same method as the tie rod ends to pop the ball joints loose. Make absolutely certain that the castle nuts are still threaded partially on the ball joint stems. This will prevent the front springs from exiting the vehicle under great pressure.
- 5.** Using a floor jack, raise the lower control arm to relieve spring tension. Remove the ball joint nuts and remove the stock spindle. Place the Lowering Spindle onto the lower ball joint. Lift the upper control arm and insert the upper ball joint into the spindle. Tighten the ball joint nuts to 50 ft. lbs. and the lower ball joint to 90 ft. lbs. Install the new cotter pins included with your kit. Install the outer tie rod and torque to 35 ft. lbs. Install the new cotter pins.

- 6.** Install the vibration ring gasket and dust shield using the supplied 5/16" bolts and lock washers. Coat the spindle pin with high temp grease. Pack the new inner wheel bearings thoroughly with high temp grease and install into the new rotor. Install the new inner grease seal by gently tapping into place with a hammer.
- 7.** Install the rotor onto the spindle pine. Pack the new outer wheel bearing with high temp grease and install with the slotted washer and the castle nut. Torque the spindle nut to 15 ft. lbs. to seat the bearings. Then back off the nut to align cotter pin at nearest slot.
- 8.** Install the brake caliper onto the spindle using the included hardware. Torque the caliper bolts to 35 ft. lbs. The brake hose attaches to the caliper using the supplied banjo bolts. Make certain that you install the copper washers on each side of the brake hose fitting. Torque the banjo bolts to 22 ft. lbs. The new brake hose installs towards the rear of the vehicle and into the original crossmember bracket. Slight modification may be required to fit the hose end into the bracket.
- 9.** Remove the vertical brake lines below the brake light switch. Unbolt the stock master cylinder from the firewall. A power upgrade can be made at this point by using our truck unit, along with the brackets and linkage. A bench-bleed kit is included. After bench-bleeding the master cylinder, install the proportioning valve as shown in instructions.
- 10.** Double check all brake line fittings and bleed the entire brake system, starting at the farthest wheel from the master cylinder and working forward. Make sure to check the master cylinder fluid level after every 2-3 pumps of the brake system.

Happy motoring...

MANUAL MASTER INSTALLATION:

1. Disconnect the master cylinder push rod from the brake pedal.
2. Remove the old master cylinder.
3. Using the two holes which line up with the larger hole, install the new master.
4. Attach the master cylinder push rod to the pedal with the supplied clevis attachment.

5. Place the proportioning valve bracket onto one of the nuts that holds the master and tighten.

6. Mount the valve to the bracket.

7. Run the two supplied pre-bent lines from the master to the valve.

8. Run hard line from the valve to the front and rear part of the braking system as per the valve diagram.

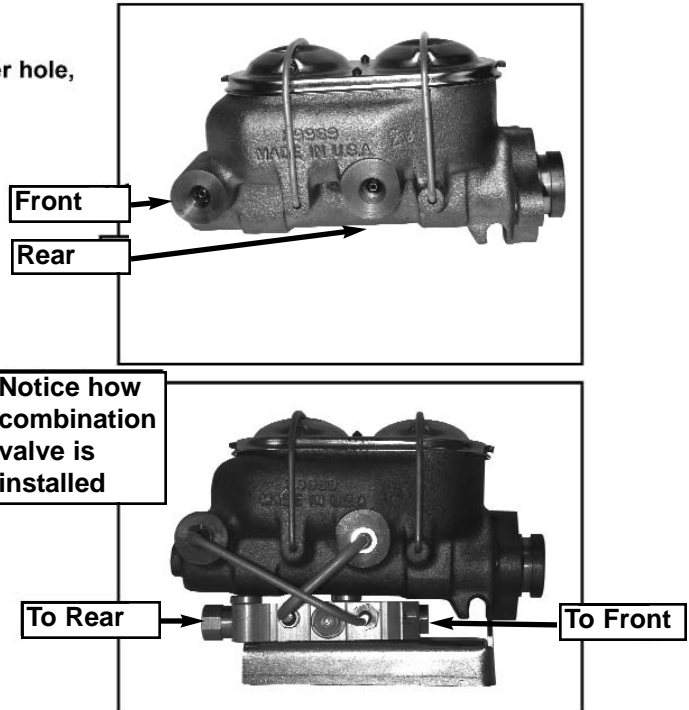

NOTE: When running lines to the front, you can plug one of the outlets on the valve (to front) and splice the one brake line to front calipers. You do not need to run two separate lines to the combination valve.

