



WARNING

Proper operation of your brakes is essential for your safety and the safety of others. Any brake service should be performed ONLY by persons experienced in the installation and proper operation of brake systems. It is the responsibility of the person installing any brake component or kit to determine the suitability of the component or kit for the particular application. After installation and before operating your vehicle, be sure to test the function of the brakes under controlled conditions.

DO NOT DRIVE WITH UNTESTED BRAKES!

FOR TECHNICAL ASSISTANCE CALL:

888-533-1199

MONDAY - FRIDAY

8:00 AM TO 5:00 PM EST

IMPORTANT

Take time to read all the literature that came with this kit. Check the provided list of parts against what you received to ensure all parts are present. While this kit was designed to make the process of changing brake parts as simple as possible. **NOTE: WITH SOME KITS IT MAY BE NECESSARY TO MAKE MINOR CHANGES TO YOUR CAR!**

READ ALL WARRANTY DISCLAIMERS AND RETURN POLICIES INCLUDED IN THIS KIT PRIOR TO INSTALLATION!

MASTER POWER BRAKES

110 CROSSLAKE PARK RD. MOORESVILLE, N.C. 28117

www.mpbrakes.com

DB1741D DB1742D SERIES INSTALLATION INSTRUCTIONS DROP SPINDLE DISC KITS

NOTE: THE INSTALLATION OF DISC BRAKES WILL REQUIRE THE USE OF 15" WHEELS. ANY ATTEMPT TO INSTALL DISC BRAKES WITH A 14" WHEEL WILL BE THE CUSTOMERS RESPONSIBILITY.

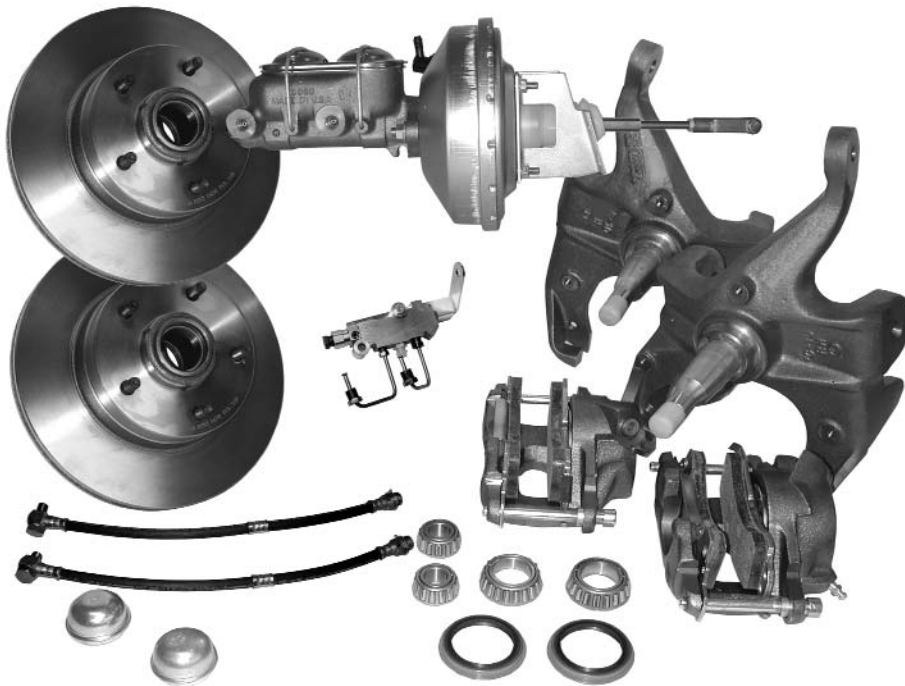

INSTALLATION INSTRUCTIONS

INCLUDED COMPONENTS

Your power brake conversion kit will contain the following components:

1. Power booster with vacuum hose and intake manifold fitting.
2. Master cylinder
3. Combination valve kit
4. Drop spindles with integral caliper bracket
5. Calipers with pads
6. Rotors
7. Bearings, seals and dust caps
8. Caliper hoses

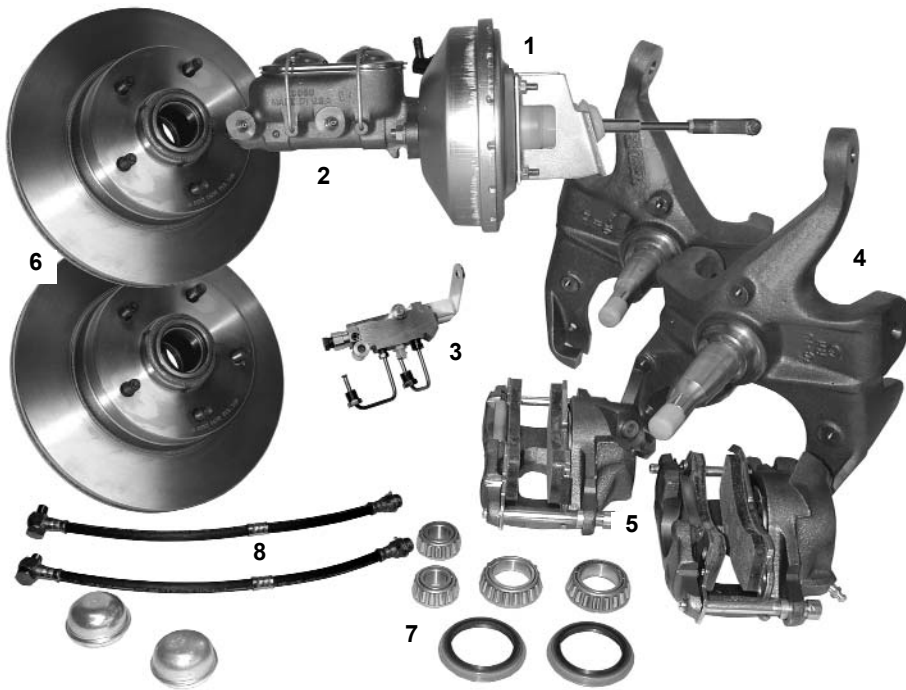

INSTALLATION

Installation of the disc brake kit will require the use of the following tools:

3/8" ratchet drive set
Box end wrench set
Pliers
Line flaring tool

Mallet
Ball joint fork
Screwdriver
Line bending tool

Flare wrench set
Drum brake tool
Snips

Always refer to the vehicle owners manual for the correct torque specifications when installing this kit

1. If you are performing the installation with a jack, be sure that the parking brake is set and that the rear wheels are chocked. Support the front of the vehicle with jack stands. Never work on sloping ground.
2. If you are using a lift, raise the vehicle to a comfortable working height.
3. Remove the front wheels.
4. At this point, be sure to place the proper support under the lower control arm. **Failure to do so will allow the coil spring to blow out when the spindle is removed which could result in serious injury and damage to the vehicle.**
5. Utilizing a mallet and screwdriver, remove the brake hose clip at the frame bracket by tapping it loose. Disconnect the brake hose from the hard line using the appropriate flare wrenches.
6. Locate the ball joint at the tie rod end and the steering arm. Remove the cotter pin and loosen the ball joint nut approximately 1/2 off. This allows for a controlled , separation. Place the ball joint fork between the steering arm and the ball joint. Strike the fork with a mallet until the steering are and ball joint separate. Remove the ball joint nut.
7. Repeat the process described in step 6 for the upper ball joint at the spindle. Place the ball joint fork between the spindle and the ball joint and remove the ball joint.
8. Slowly lower the support and remove the drum brake assembly as a unit.
9. Inspect the ball joints for signs of excessive wear and check to see if the rubber boot is torn. If the ball joint wobbles excessively or is worn, now is the time for replacement. Clean the ball joints with a rag.
10. Place the disc brake spindle onto the lower ball joint. Torque the nut to the specification in the owners manual. Insert the cotter pin and bend it.
11. Raise the control arm support and repeat step 10 for the upper ball joint. Remember to use the torque specification in the owners manual.
12. The caliper bracket is located on the spindle so that the caliper will be mounted toward the rear of the vehicle.
13. Attach the steering arm to the tie rod. Torque the nut to the recommended specification. Install the cotter pin and bend it.
14. Check the fit of the inner and outer bearing on the spindle. If the fit is too tight, lightly sand the spindle with emery cloth until the bearings slide on easily.

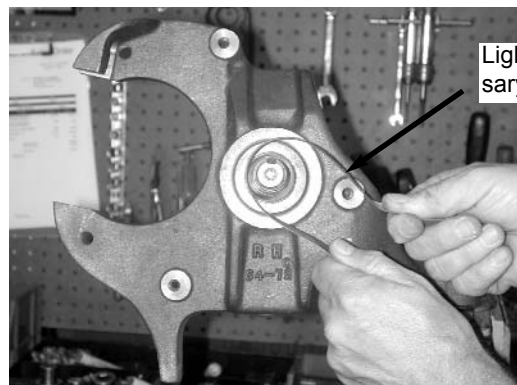

Lightly sand as necessary for inner bearing fit

15. **Grease the inner and outer bearing** by "packing" grease between the rollers and coating the inside and out side diameters. **Be sure to use a good high temperature bearing grease.**

16. Grease the inner and outer race on the inside of the rotor. Install the inner bearing into the rotor. Lightly tap the grease seal into place with a mallet until it is seated. **Clean the rotor before installation with brake cleaner followed by soap and water.**

Install the greased inner bearing into the rotor

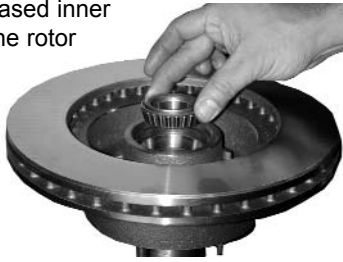

Install the grease seal into the rotor



17. Grease the spindle where the bearings fit. Install the rotor onto the spindle followed by the outer bearing, the keyed washer and spindle nut. Tighten the spindle nut to the specified torque and insert the cotter pin. Bend the cotter pin, snip off the excess, and install the dust cap, by tapping a socket that fits on the cap edge, or by tapping a screwdriver on the edge of the cap. Spin the rotor and check to be sure that it rotates smoothly and there is no wobble. **Clean the rotor.**



Mount the rotor with the installed inner bearing onto the rotor

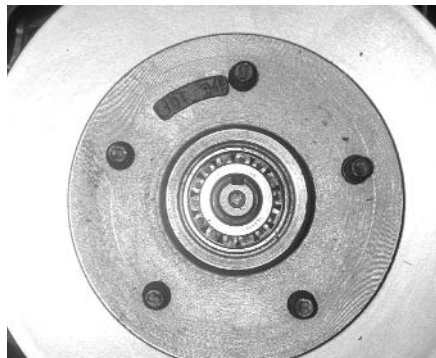

Install the greased outer bearing

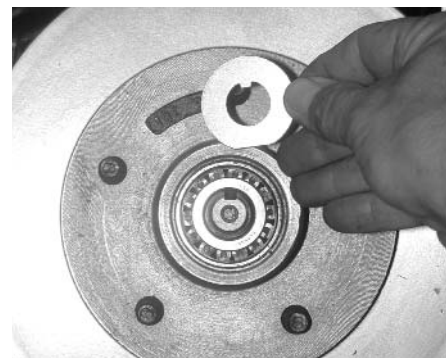

Install the keyed washer

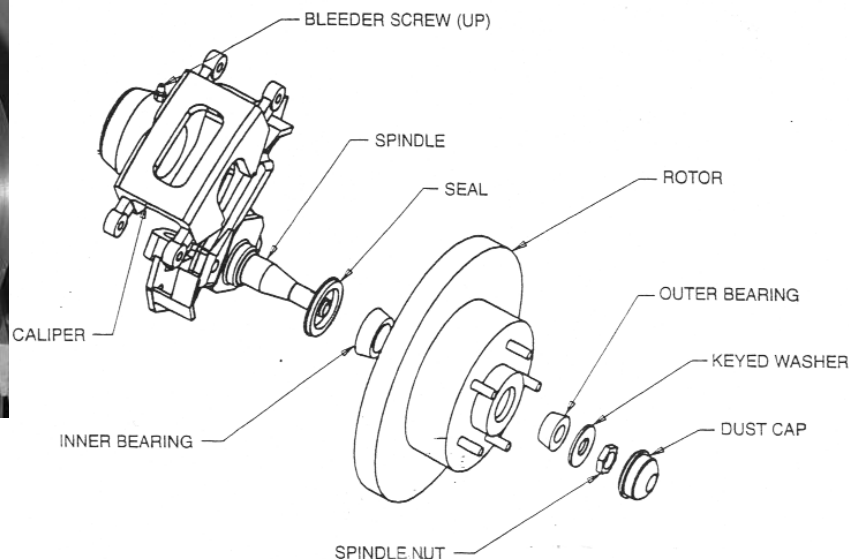
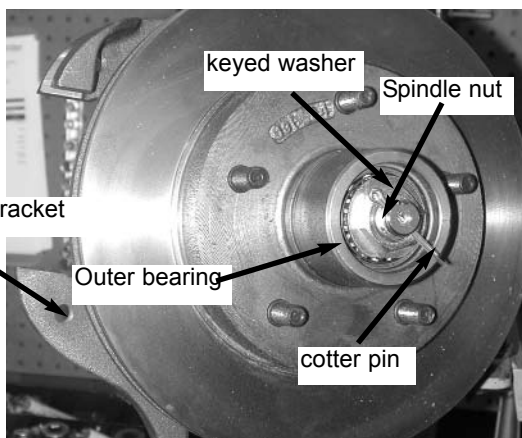

18. Install the loaded caliper onto the mounting bracket with the bleeder screw facing up. Insert the caliper mounting bolts and torque to the recommended specifications. Spin the rotor to be sure that it rotates smoothly. **The bleeder screw on the caliper must be on top.**

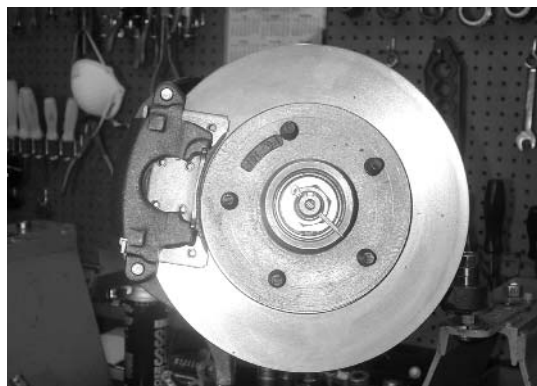
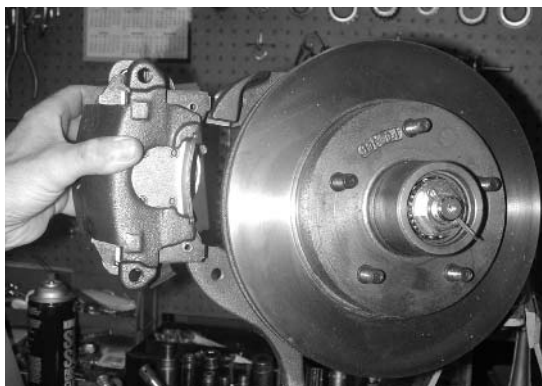

Bleeder screw must be on top of caliper

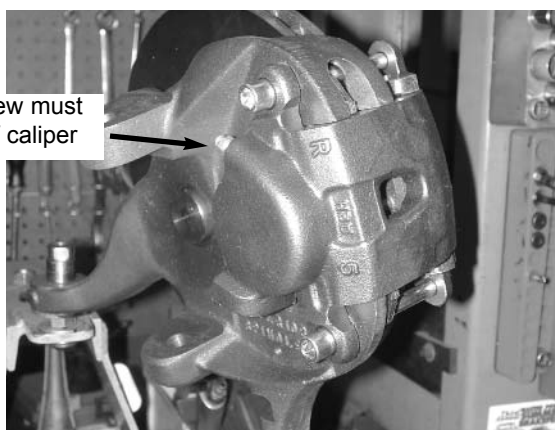

Caliper mounting bolts

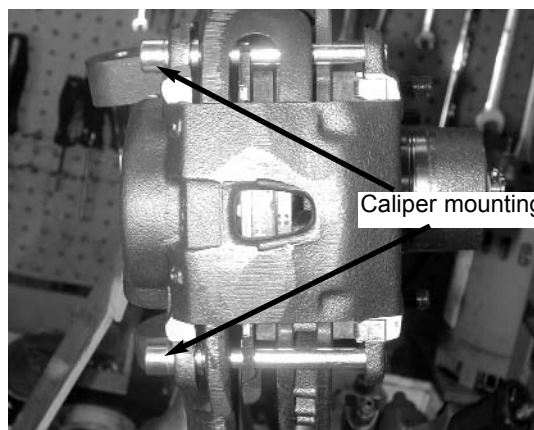

19. Install the hose onto the caliper. Be sure that the brass end of the hose is sandwiched between the two copper washers. The sequence must be: bolt - washer - hose fitting - washer - caliper. Tighten the bolt to the recommended specifications.
20. Using the flare wrenches, attach the other end of the hose to the hard line at the chassis. Tap the hose clip back into place with a mallet. Turn the steering assembly full right and left to be sure that the hose does not bind or twist.
21. Repeat this process for the other side and the disc portion of the conversion is complete.

MASTER CYLINDER / POWER BOOSTER INSTALLATION

1. Disconnect the old master cylinder lines (Remember, if operating around painted surfaces, avoid brake fluid to paint contact). Remove any valves that are installed in the drum system and discard. If the vehicle has a pressure differential switch, it must also be removed. Remove the old master cylinder.
2. When changing from a manual brake system to a power system, the clevis assembly that attaches the push rod to the brake pedal must be removed and lowered one inch. If two holes are in the pedal use the lower hole for the power booster rod attachment. If only one hole exists from the manual system a second hole must be drilled one inch lower. Remove the clip and pin that attaches the clevis to the brake pedal and retain them. If the lower hole does not already exist, one must be drilled. Screw the clevis assembly onto the new push rod on the booster about 1 1/2".
3. Mount the booster to the firewall with the existing studs or bolts. Place the clevis assembly into the lower hole in the pedal and install the pin and clip.

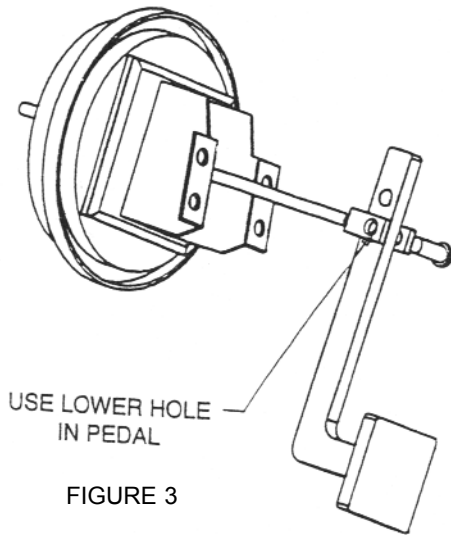

FIGURE 3

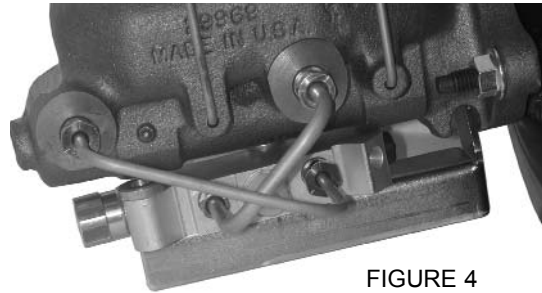
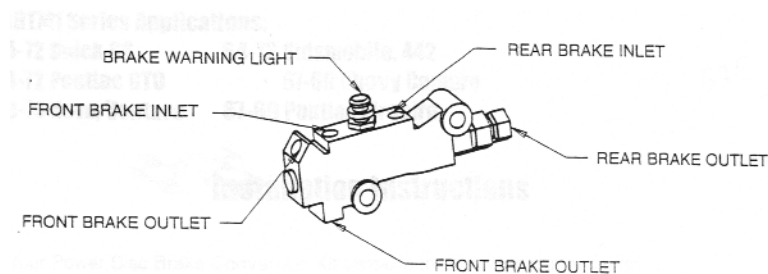

FIGURE 4

If you are installing disc brakes without a power booster just mount the manual master to the firewall on the two studs that line up with the large hole. Attach the manual brake push rod to the pedal in the upper hole and adjust it so that it seats into the piston hole without applying pressure to the piston while at rest.

4. Install the proper fitting into the intake manifold for vacuum. Connect the vacuum hose from the engine to the power booster. **YOU WILL NEED AT LEAST 18" VACUUM TO OPERATE A BOOSTER.**
5. Bench bleed the master cylinder with the supplied bleeder kit.
6. Install the master cylinder onto the booster.
7. Mount the combination valve to supplied bracket and attach the bracket and lines as shown in fig. 4.
8. You will now need to run two lines from the supplied combination valve to the frame. Tie the lines into the existing front and rear lines with brake line couplers. You may run two separate lines from the combination valve to each front wheel or you may plug one outlet to the front, run one line and then split it to each front wheel.



9. Flush out the old brake fluid and replace with DOT 4.
10. Bleed the entire system starting at the wheel farthest from the master cylinder. Check the pedal feel for firmness. Adjust the clevis so there is 1/4" free play at the pedal stop. If pedal is spongy, bleed again.

TEN REASONS FOR A POOR BRAKE PEDAL

CAUSE

REASON

1. Bleeder screws on calipers not on top.

1. The bleeder screws on calipers must be at the 12:00 position on the caliper to allow all the air to escape during bleeding. A very common mistake installers will make is to reverse the side the caliper goes on giving you a situation where the caliper bleeder screw is facing down. It's also common to use the wrong caliper on a bolt on disc kit giving a situation where the bleeder hole is shifted from the 12:00 position producing a pocket of air at the top of the caliper bore which can not be dislodged. Check your bleeder hole orientation.

2. A defective master cylinder which does not hold pressure.

2. If brake fluid bypasses a pressure seal on a master cylinder you will get a pedal that fades. To test for this obtain two inverted flare plugs at an auto parts store and plug both master cylinder outlets. Try your pedal. If the pedal is high and firm the master is good. If the pedal fades the master is bad. Replace master as necessary.

3. No residual pressure valve to rear drum brakes.

3. Drum brakes require the use of a 10 lb residual pressure valve in the line. This residual pressure counter balances the drum brake spring tension keeping the shoes close to the drums. This results in a higher firmer pedal. You can test this by clamping off the rear hose removing the rear drums from the system. Now test your pedal. If the pedal gets better you will need to splice a 10 lb residual pressure valve into the rear line.

4. Hard line that loops up.

4. Hard brake line that loops up and then back down will tend to trap air. It doesn't take much air to cause problems so check your lines carefully.

5. Incorrect master cylinder.

5. If the bore size of the master cylinder is too small for the fluid requirements of the system you will get a very poor pedal. This will happen most frequently with four piston calipers and with four wheel disc brakes. The only solution for this is to install a larger bore master cylinder or a true four wheel disc master.

6. Incorrectly bled or adjusted rear calipers.

6. Rear calipers that have an internal parking brake with a lever can be troublesome. These calipers must be adjusted so that the piston is moved out and the pads are close to the rotor. If this initial adjustment is not made the pistons will travel outward during activation but no squeezing of the rotor will occur. This can be checked by clamping off the rear hoses and checking if the pedal gets better. Adjust as necessary.

7. Incorrect booster pin length.

7. The booster pin that pushes on the master cylinder must almost be touching the master cylinder piston face. A gap larger than 1/32" will begin to introduce a spongy pedal. Adjust as necessary.

8. Silicone brake fluid.

8. While silicone fluid is great because it does not attack paint it also aerates very easily and can give a spongy pedal.

9. Rear wheel cylinders too large.

9. Rear drum wheel cylinders that are too large will give a poor pedal. Check as in step six above.

10. Loose front wheel bearings.

10. Loose front wheel bearings will cause rotor wobble. This will cause the caliper pistons to retract too far into the caliper giving a spongy pedal every time you hit the brakes. Check and adjust as necessary.

DB1742PD
DISC KIT, DROP 64-72 GTO, CHEVELLE, SKYLARK
2" DROP FRONT STEER
PARTS LIST

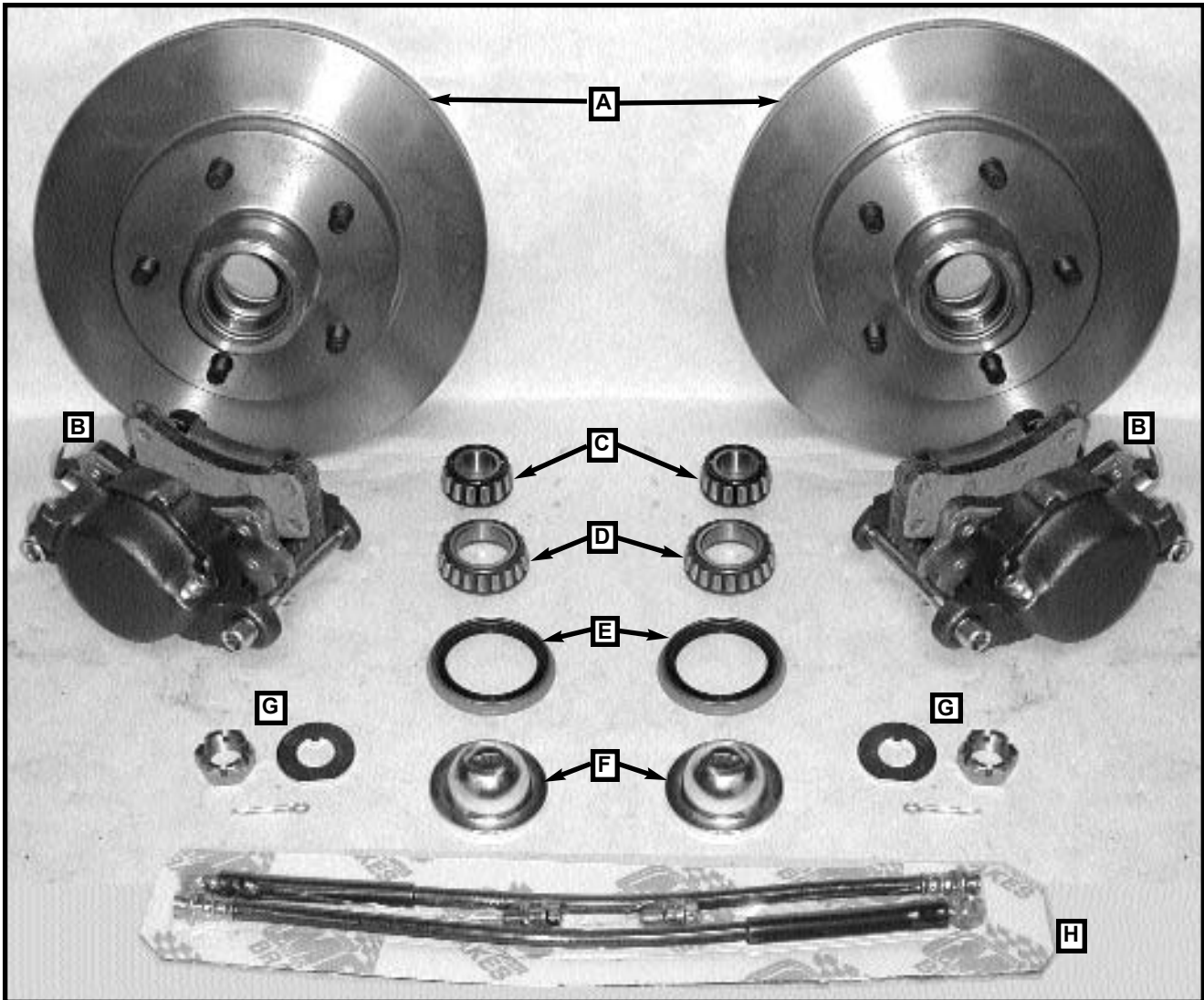

PARTS LIST

- A) (2) RT141219 ROTOR, F, 79-812 GM MID-SIZE USED WITH DROP SPINDLES
- B) (2) CA412526 CALIPERS, SET SMALL GM USED IN DROP SPINDLE APPLICATIONS
- C) (2) HWA3 BEARING, OUTER
- D) (2) HWA6 BEARING, INNER
- E) (2) HW8871 SEAL, ROTOR
- F) (2) HW4002 CAP, DUST, 53.2/ 2 3/32
- G) (1) HW1701K SPINDLE NUT/ WASHER KIT, 3708
 - (2) 12R100PCOZ COTTER PIN, 1/8 X 1"
 - (2) HW615005 WASHER, SPINDLE ORG. GM
 - (2) HW615065 NUT, SPINDLE GM
- H) (1) HS5157K HOSE KIT, 18" HOSES 10MM
 - (2) HS5157 HOSE, 18" 10MM HOSE
 - (4) HW21206 WASHER, COPPER USED FOR METRIC HOSE BOLTS
 - (2) HW5155 10MM METRIC BOLT COURSE

DB1742PD
CONTINUED

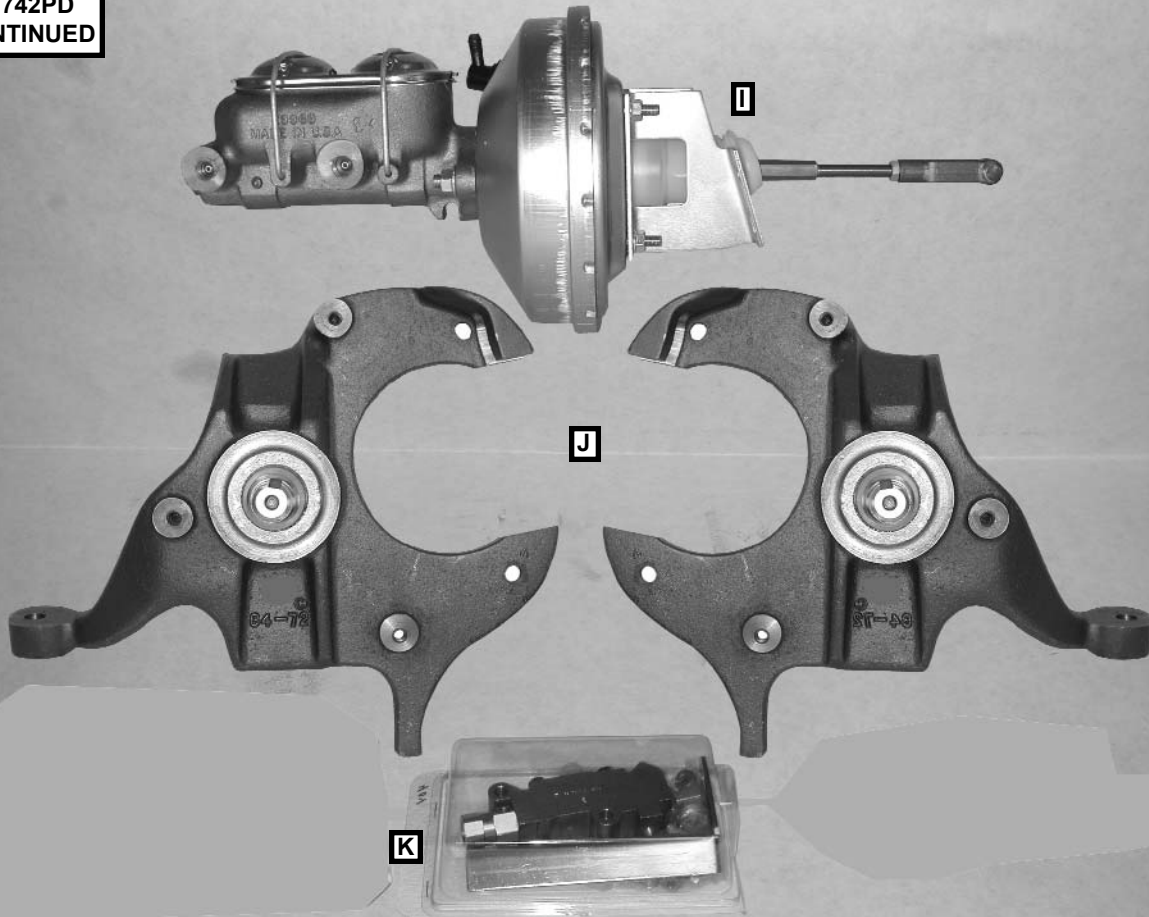

PARTS LIST (CONT.)

- I) (1) BM1741 BOOSTER, M/C, 9" SLIMLINE, 64-74 MIDSIZE, 67-69 CAMARO, 68-74 NOVA
- J) (2) SP8742D SPINDLES, DROP CHEVELLE 64-72 FRONT STEER
- K) (1) VL3360K VALVE KIT, W/ FITTINGS
 - (1) 25C175HCS5Z 1/4 X .175 BOLT
 - (1) 25CNNEZ 1/4 COURSE NYLOCK NUT
 - (1) BR1261N BRACKET, VALVE, UNIVERSAL
 - (2) HW105-3 NUT, 3/16 TUBE 3/8-24 THD
 - (1) HW106-3 PLUG, 3/16"
 - (2) HW106-4 PLUG, INVERTED STEEL 1/4" O.D.
 - (1) HW115-37 NUT, 3/16 TUBE 7/16-24 THD RED
 - (1) HW115-38 NUT, 3/16 TUBE 1/2-20 THD BLACK
 - (1) HW115-39 NUT, 3/16 TUBE 9/16-18 THD OLIVE
 - (1) HW1709 PLUG, SWITCH, COMBO VALVE
 - (1) HW210-43 ADAPTOR, BRASS 7/16-3/8M
 - (2) HW300-3 COUPLER 3/16
 - (2) HW300-4 COUPLER 1/4
 - (2) HW300-5 COUPLER 1/2
 - (1) HW3359 PLUG, COMBO VALVE, 4 WHEEL DISC
 - (1) HW702-3 T-FITTING 3/16 X 3/16 X 3/16
 - (1) VL3350 VALVE, COMBO, DISC / DRUM

MASTER POWER BRAKES 888-533-1199