



MASTER POWER BRAKES

110 Crosslake Park Road, Mooresville, NC 28117

Website: www.mpbrakes.com

Technical Support: 888-533-1199

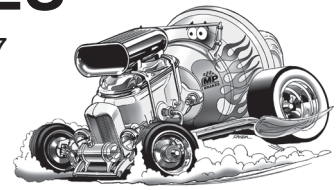

WARNING

Proper operation of your brakes is essential for your safety and the safety of others. Any brake service should be performed **ONLY** by persons experienced in the installation and proper operation of brake systems. It is the responsibility of the person installing the component or kit for the particular application. After installation and before operating your vehicle, be sure to test the function of the brakes under controlled conditions.

→ **DO NOT DRIVE WITH UNTESTED BRAKES!** ←

FOR TECHNICAL ASSISTANCE CALL:

888-533-1199

MONDAY - FRIDAY

8:00 A.M. TO 5:00 P.M. E.S.T.

CHECK ORDER IMMEDIATELY WARRANTY INFORMATION

Take time to read all the literature that came with this kit. Check the provided list of parts against what you received to ensure all parts are present. While this kit was designed to make the process of changing brake parts as simple as possible, **with some kits it may be necessary to make minor changes to your car.**

Read all warranty disclaimers and return policies included in this kit prior to installation.

You have: **5 days** to declare shipping damages
30 days to declare missing or incorrect parts
90 days for exchanges or returns (RA req'd)
1 year before product warranty expires.

No exceptions allowed.

Thank you for your business!



MASTER POWER BRAKES

110 Crosslake Park Road, Mooresville, NC 28117

Website: www.mpbrakes.com Technical Support: 888-533-1199

© 2006 MP Brakes. All rights reserved. Master Power® is a registered trademark of Master Power Brakes, LLC



INSTALLATION INSTRUCTIONS

INCLUDED COMPONENTS

Your disc brake conversion kit will contain the following components:

1. Disc brake spindles
2. Caliper brackets
3. Calipers with pads
4. Rotors
5. Splash shields
6. Bearings, seals and dust caps
7. Caliper hoses

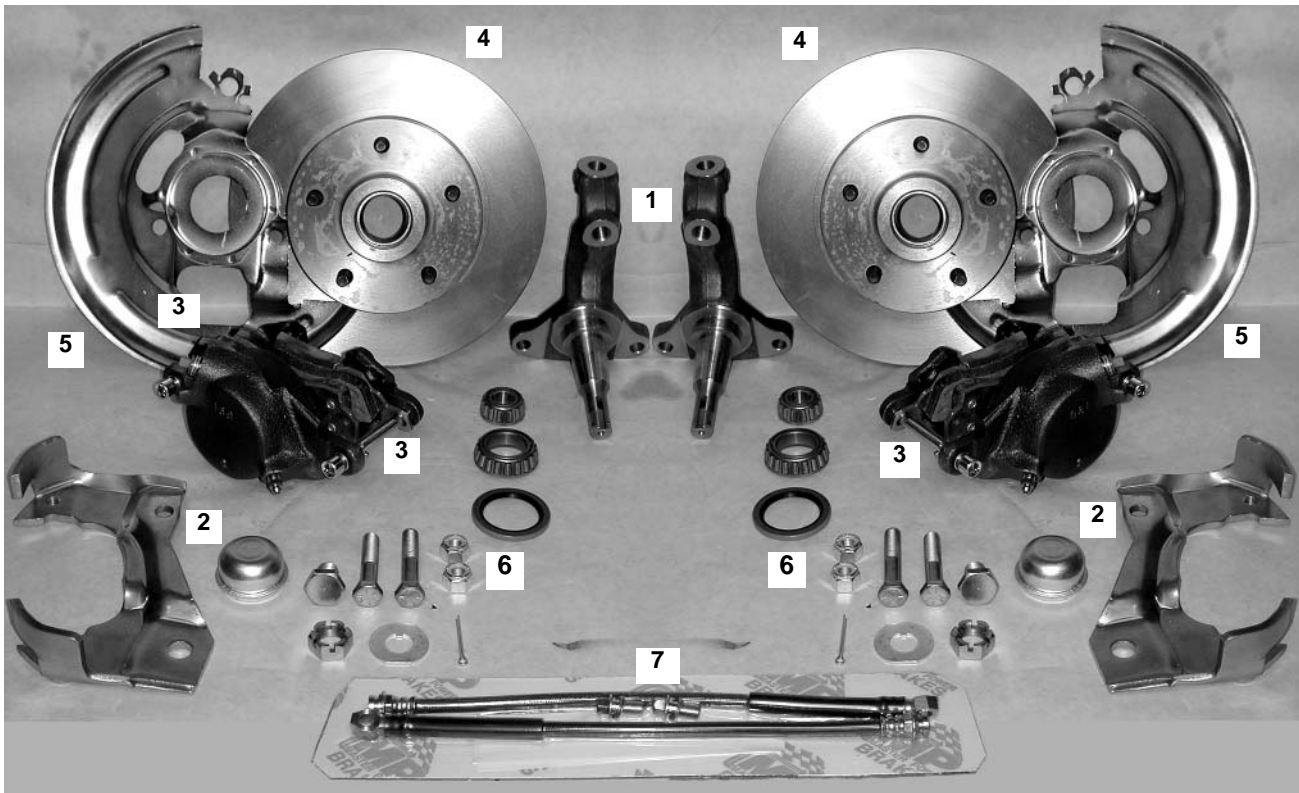

INSTALLATION

Installation of the disc brake kit will require the use of the following tools:

3/8" ratchet drive set
Box end wrench set
Pliers
Line flaring tool

Mallet
Ball joint fork
Screwdriver
Line bending tool

Flare wrench set
Drum brake tool
Snips

Always refer to the vehicle owners manual for the correct torque specifications when installing this kit

1. If you are performing the installation with a jack, be sure that the parking brake is set and that the rear wheels are chocked. Support the front of the vehicle with jack stands. Never work on sloping ground.
2. If you are using a lift, raise the vehicle to a comfortable working height.
3. Remove the front wheels.
4. At this point, be sure to place the proper support under the lower control arm. Failure to do so will allow the coil spring to blow out when the spindle is removed which could result in serious injury and damage to the vehicle.
5. Utilizing a mallet and screwdriver, remove the brake hose clip at the frame bracket by tapping it loose. Disconnect the brake hose from the hard line using the appropriate flare wrenches.
6. Locate the ball joint at the tie rod end and the steering arm. Remove the cotter pin and loosen the ball joint nut approximately 1/2 off. This allows for a controlled , separation of the tie rod end and the steering arm. Place the ball joint fork between the steering arm and the ball joint. Strike the fork with a mallet until the steering are and ball joint separate. Remove the ball joint nut.
7. Repeat the process described in step 6 for the lower and upper ball joint at the spindle. Place the ball joint fork between the spindle and the ball joint.
8. Slowly lower the support and remove the drum brake assembly as a unit.
9. Inspect the ball joints for signs of excessive wear and check to see if the rubber boot is torn. If the ball joint wobbles excessively or is worn, now is the time for replacement. Clean the ball joints with a rag.
10. Take the drum brake assembly to a bench to disassemble it. Remove the dust cover by twisting a screwdriver between the dust cover and the hub. Remove the cotter pin and take off the spindle nut. Save the spindle nut and the keyed washer to use on the disc spindle. Remove the bolts that hold the steering are to the spindle and retain the arm and the bolts to use on the disc spindle. (This requires removing the brake shoes which is easier with a drum brake tool.)
11. Place the disc brake spindle onto the lower ball joint. Torque the nut to the specification in the owners manual. Insert the cotter pin and bend it.
12. Raise the control arm support and repeat step 11 for the upper ball joint. Remember to use the torque specification in the owners manual.
13. The caliper bracket attaches to the spindle so that the caliper will be located toward the rear of the vehicle. This is accomplished by mounting the bracket with the ears toward the rear and the "tangs" pointing toward the out side (see Figure 1). Using the 5/8" bolt supplied, attach the bracket to the spindle. Attach the steering arm with the bolts from the drum assembly, using one of the bolts to attach the bracket to the spindle. Torque all three bolts to the specifications in the owners manual.

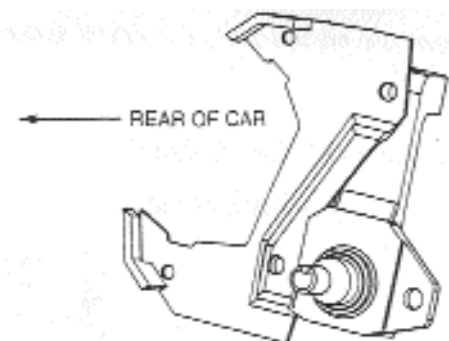

FIGURE 1



FIGURE 2

14. Attach the steering arm to the tie rod. Torque the nut to the recommended specification. Install the cotter pin and bend it. Place the .322" thick spacer onto the stud with the thinner hole on the steering arm.
15. Check the fit of the inner and outer bearing on the spindle. If the fit is too tight, lightly sand the spindle with emery cloth until the bearings slide on easily.
16. Grease the inner and outer bearing by "packing" grease between the rollers and coating the inside and outside diameters. Be sure to use a good high temperature bearing grease.
17. Grease the inner and outer race on the inside of the rotor. Install the inner bearing into the rotor. Lightly tap the grease seal into place with a mallet until it is seated. **(Clean the rotor before installation with brake cleaner followed by soap and water.)**

Install the greased inner bearing into the rotor.



Install the grease seal into the rotor.



18. Grease the spindle where the bearings fit. Install the rotor onto the spindle followed by the outer bearing, the keyed washer, a new-spindle nut. Tighten the spindle nut to the specified torque and insert the cotter pin. Bend the cotter pin, snip off the excess, and install the dust cap, by tapping a socket that fits on the cap edge, or by tapping a screwdriver on the edge of the cap. Spin the rotor and check to be sure that it rotates smoothly and there is no wobble. Clean the rotor.
19. Install the loaded caliper onto the mounting bracket with the bleeder screw facing up (Notice the diagram). Insert the caliper mounting bolts and torque to the recommended specifications. Spin the rotor to be sure that it rotates smoothly.
20. Install the hose onto the caliper. Be sure that the brass end of the hose is sandwiched between the two copper washers. The sequence must be: bolt - washer - hose fitting - washer - caliper. Tighten the bolt to the recommended specifications.
21. Using the flare wrenches, attach the other end of the hose to the hard line at the chassis. Tap the hose clip back into place with a mallet. Turn the steering assembly full right and left to be sure that the hose does not bind or twist.
22. Repeat this process for the other side and the disc portion of the conversion is complete.

Notice bleeder screw is up.

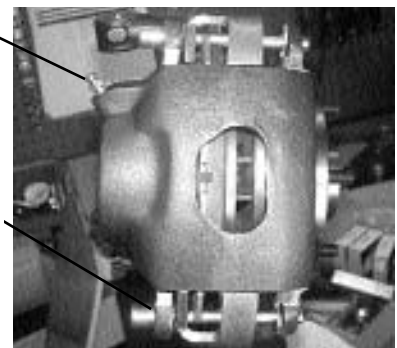

Caliper bolts thread into bracket.

Bend over cotter pin.

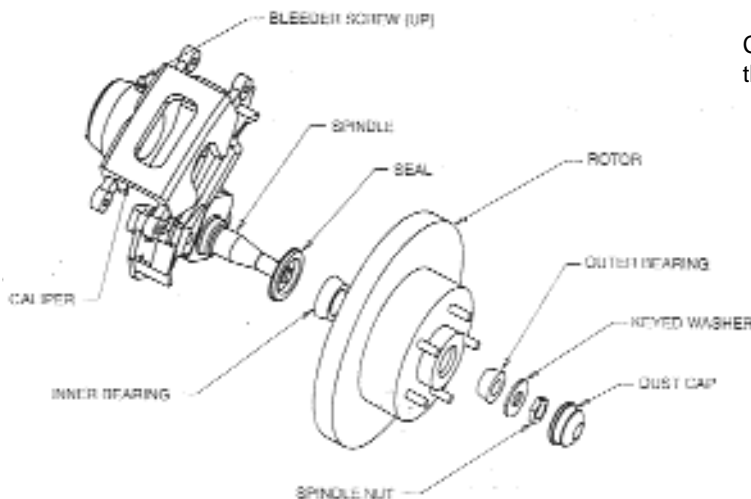

MANUAL MASTER INSTALLATION:

1. Disconnect the master cylinder push rod from the brake pedal.
2. Remove the old master cylinder.
3. Using the two holes which line up with the larger hole, install the new master.
4. Attach the master cylinder push rod to the pedal with the supplied clevis attachment.
5. Place the proportioning valve bracket onto one of the nuts that holds the master and tighten.
6. Mount the valve to the bracket.
7. Run the two supplied pre-bent lines from the master to the valve.
8. Run hard line from the valve to the front and rear part of the braking system as per the valve diagram.

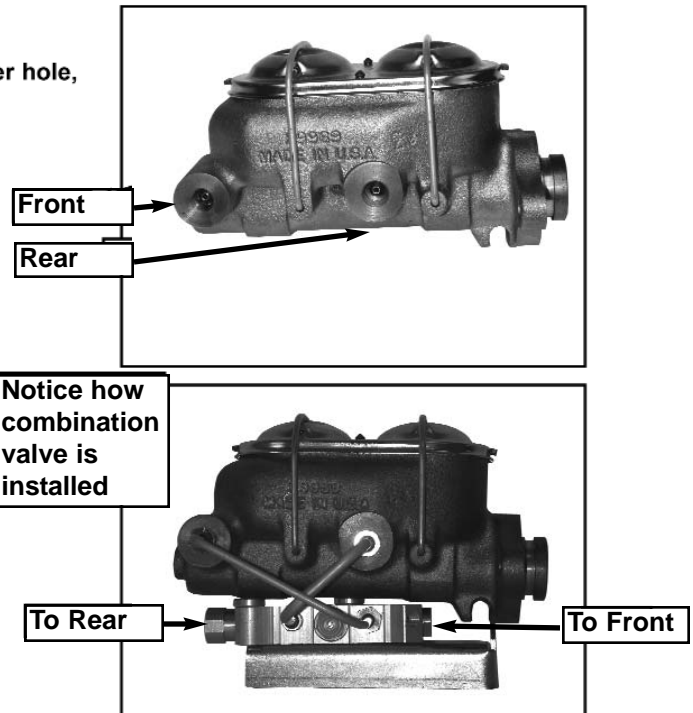

NOTE: When running lines to the front, you can plug one of the outlets on the valve (to front) and splice the one brake line to front calipers. You do not need to run two separate lines to the combination valve.

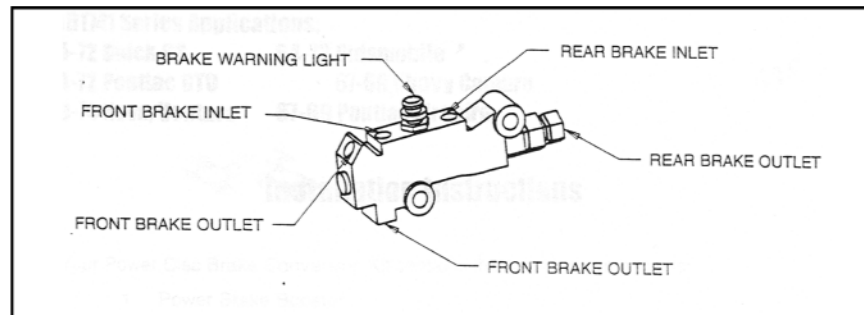

DB1731M
DISC BRAKE KIT, MANUAL, 64-67 CHEVY II
PARTS LIST

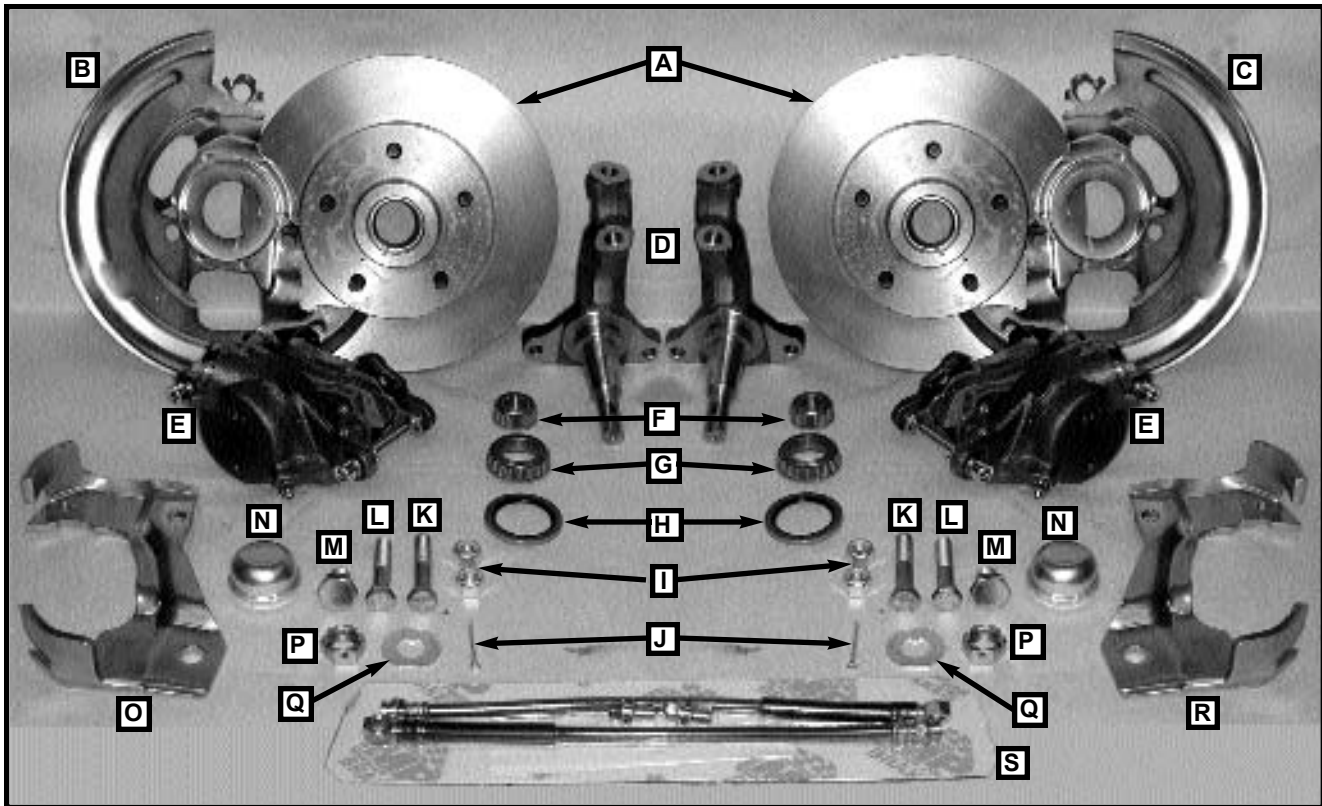

PARTS LIST

- A) (2) RT141039 ROTOR, SINGLE PISTON CALIPER 69-72 CHEVELLE, 67-69 CAMARO, 69-74 MONTE CARLO
- B) (1) AC1700D DUST SHIELD, GM, DRIVER-SIDE
- C) (1) AC1700P DUST SHIELD, GM, PASS.-SIDE
- D) (2) SP1731 SPINDLES, DISC BRAKE, CHEVY II ***NEW***
- E) (2) CA403940 CALIPERS, GM, LARGE, SINGLE PISTON
- F) (2) HWA2 BEARING, OUTER
- G) (2) HWA6 BEARING, INNER
- H) (2) HW8705 SEAL, ROTOR
- I) (4) 50FNNEZ NUT, 1/2-20, NYLOCK, ZINC
- J) (2) 12R150PCOZ PIN, COTTER, 1/8 X 1 1/2 ZINC
- K) (2) 50F275HCS8Y BOLT, 1/2-20 X 2 3/4 HCS GR-8 ZINC YELLOW
- L) (2) 50F250HCS8Y BOLT, 1/2-20 X 2 1/2 HCS ZINC YELLOW
- M) (2) HW1702 BOLTS, CALIPER BRACKET
- N) (2) HW4001 CAPS, DUST, 45.2MM /1 25/
- O) (1) BRCA1741L BRACKETS, CALIPER LEFT S 64-72 GM MID-SIZE
- P) (2) HW615065 NUT, SPINDLE, GM
- Q) (2) HW615005 WASHER, SPINDLE ORG. GM
- R) (1) BRCA1741R BRACKETS, CALIPER RIGHT S 64-72 GM MID-SIZE
- S) (1) HS88520K HOSE KIT, FRONT, 69-77, 16 GM, SINGLE PISTON CALIPER SET
 - (2) HS88520 HOSE, F, 69-71 CAMARO 16
 - (2) HW210-82 BOLT, HOSE 7/16 X 20 SHORT
 - (4) HW4390 COPPER SEALING WASHER USED W/ 4039 & 4040 CALIPER

DB1731M
CONTINUED

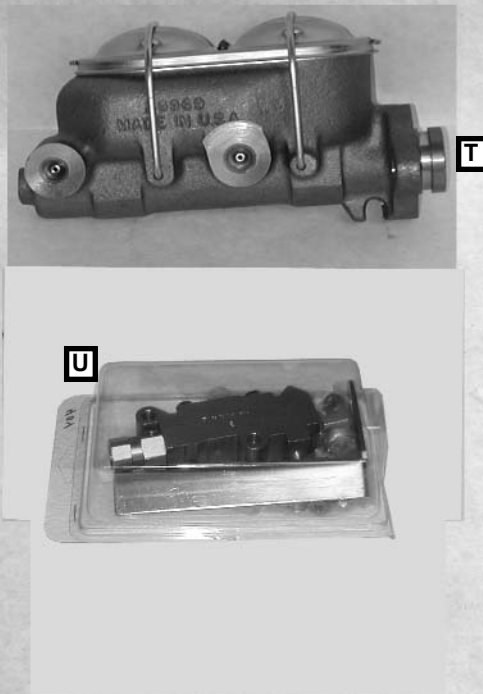

PARTS LIST

- T) (1) MC390360M MASTER CYLINDER, GM, 1" BORE, 7/16" STROKE
DUAL RESERVOIR
- U) (1) VL3360K VALVE KIT, W/ FITTINGS
- (1) 25C175HCS5Z 1/4 X .175 BOLT
 - (1) 25CNNEZ 1/4 COURSE NYLOCK NUT
 - (1) BR1261N BRACKET, VALVE, UNIVERSAL
 - (2) HW105-3 NUT, 3/16 TUBE 3/8-24 THD
 - (1) HW106-3 PLUG, 3/16"
 - (2) HW106-4 PLUG, INVERTED STEEL 1/4" O.D.
 - (1) HW115-37 NUT, 3/16 TUBE 7/16-24 THD RED
 - (1) HW115-38 NUT, 3/16 TUBE 1/2-20 THD BLACK
 - (1) HW115-39 NUT, 3/16 TUBE 9/16-18 THD OLIVE
 - (1) HW1709 PLUG, SWITCH, COMBO VALVE
 - (1) HW210-43 ADAPTOR, BRASS 7/16-3/8M
 - (2) HW300-3 COUPLER 3/16
 - (2) HW300-4 COUPLER 1/4
 - (2) HW300-5 COUPLER 1/2
 - (1) HW3359 PLUG, COMBO VALVE, 4 WHEEL DISC
 - (1) HW702-3 T-FITTING 3/16 X 3/16 X 3/16
 - (1) VL3350 VALVE, COMBO, DISC / DRUM

MASTER POWER BRAKES 888-533-1199