



## **WARNING**

Proper operation of your brakes is essential for your safety and the safety of others. Any brake service should be performed ONLY by persons experienced in the installation and proper operation of brake systems. It is the responsibility of the person installing any brake component or kit to determine the suitability of the component or kit for the particular application. After installation and before operating your vehicle, be sure to test the function of the brakes under controlled conditions.

**DO NOT DRIVE WITH UNTESTED BRAKES!**

**FOR TECHNICAL ASSISTANCE CALL:**

**888-533-1199**

**MONDAY - FRIDAY**

**8:00 AM TO 5:00 PM EST**

## **IMPORTANT**

Take time to read all the literature that came with this kit. Check the provided list of parts against what you received to ensure all parts are present. While this kit was designed to make the process of changing brake parts as simple as possible. **NOTE: WITH SOME KITS IT MAY BE NECESSARY TO MAKE MINOR CHANGES TO YOUR CAR!**

**READ ALL WARRANTY DISCLAIMERS AND RETURN POLICIES INCLUDED IN THIS KIT PRIOR TO INSTALLATION!**

**MASTER POWER BRAKES**

**110 CROSSLAKE PARK RD. MOORESVILLE, N.C. 28117**

**[www.mpbrakes.com](http://www.mpbrakes.com)**

## INSTALLATION INSTRUCTIONS DB1711 SERIES

### INCLUDED COMPONENTS

Your disc brake conversion kit will contain the following components:

1. Caliper mounting brackets and hardware
2. Calipers with pads
3. Rotors
4. Bearings, seals and dust caps
5. Caliper hoses

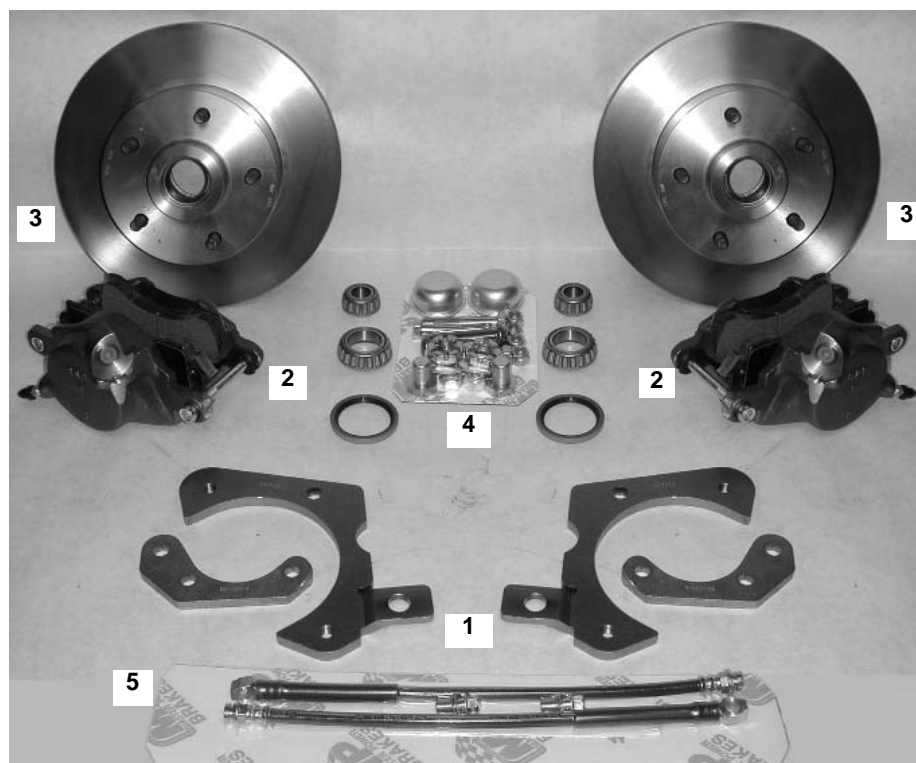

### INSTALLATION

Installation of the disc brake kit will require the use of the following tools:

3/8" ratchet drive set  
Box end wrench set  
Pliers  
Line flaring tool

Mallet  
Ball joint fork  
Screwdriver  
Line bending tool

Flare wrench set  
Drum brake tool  
Snips

Always refer to the vehicle owners manual for the correct torque specifications when installing this kit

1. Remove the stock Chevy front drums, brakes and backing plates. Clean and inspect the spindles for cracks or damage. Be sure to thoroughly clean out the 5/8" threaded hole at the top of the spindle. This is extremely important. Use a non oil based cleaner such as Brake Clean. Clean the threads out with a bottoming tap if necessary.
2. In order to install the inner bearing on some spindles, you must remove .0004" from the inner bearing seating diameter. This can be accomplished with 240 grit emery paper and a rotary sanding motion on the spindle. This operation must be continued until the inner bearing can be slid onto the spindle without binding. Do not try grinding or filing the spindle. It only takes a few minutes with emery paper.
3. Once the bearings have been fitted to the-spindle, take the small support bracket (see figure) and install it on the outer surface of the spindle in the two lower holes. Install the shorter 7/16-20 bolt (2 1/4") in a similar manner through the front hole. Install the locknuts supplied in the kit and tighten.
4. Take the appropriate caliper bracket (LH or RH as marked on the inside of the bracket) and install it as per the figure. Install the 1/2" x 2 1/2" bolt and support bracket as shown. Install the 1/2" locknut but do not tighten it yet, just snug it up.

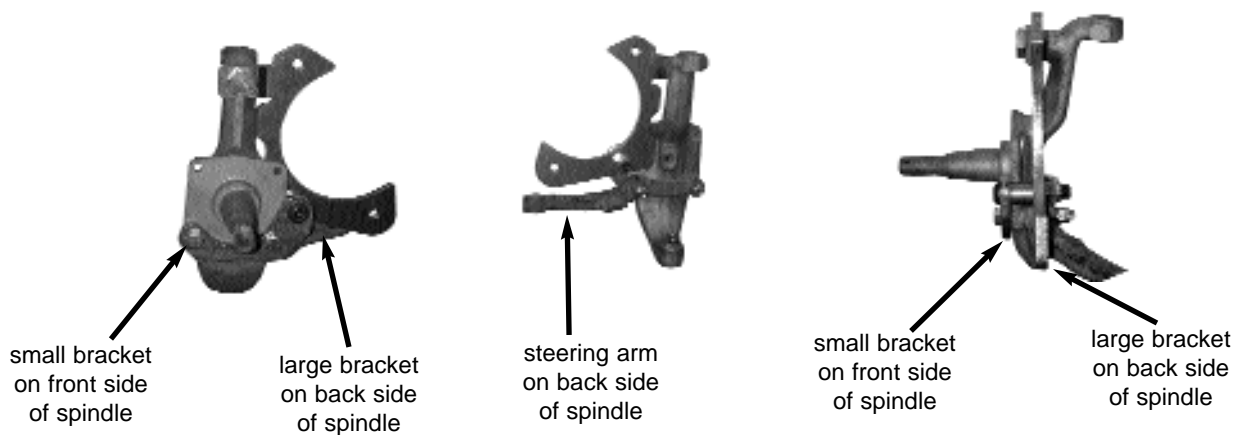

5. Take the 5/8 x 1" bolt and install it through the bracket into the spindle. Do not tighten it yet, just snug it up.
6. Take the rotor, clean it and inspect as necessary. Install the inner bearing with grease followed by the 7934 S seal.
7. Install the rotor on the spindle followed by the outer bearing. Put the bearing retaining washer and nut-on the spindle to hold everything in place temporarily.
8. Turn the rotor on the spindle and check for any interference or minimal clearance between the inside surface of the rotor and the attaching hardware.
9. When you have adequate clearance, make sure the threads in the spindle are clean. Install the bolt, tighten it and the 1/2" bolt previously installed.
10. Re-check all the bolts--for tightness and re-install the rotor and. outer bearing. Install the new bearing retainer washer followed by the special wheel bearing retaining nut supplied in the kit. Do no attempt to use the stock bearing- nut, the cotter pin hole will not line up. Adjust the wheel bearings and install the cotter pin. Check for clearance and freedom of movement once more.
11. Install the caliper on the bracket (remember there is a left hand and right hand caliper) using the standard GM caliper mounting belts. Tighten bolts to recommended GM torque specifications. **BLEEDER SCREWS MUST FACE UP ON THE CALIPERS.**
12. Repeat the procedure for the opposite side.
13. Connect the calipers to the brake lines using the supplied hoses.

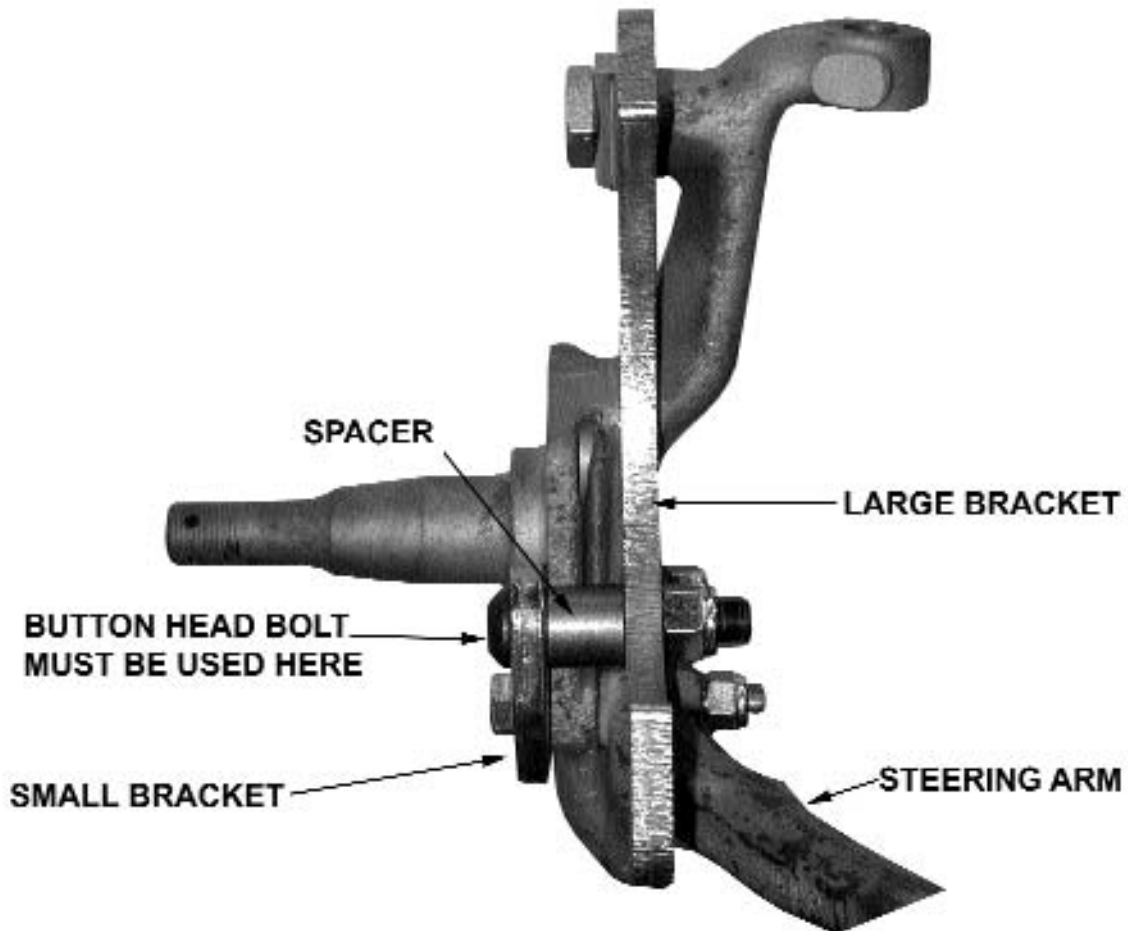

**MANUAL MASTER INSTALLATION:**

1. Disconnect the master cylinder push rod from the brake pedal.
2. Remove the old master cylinder.
3. Using the two holes which line up with the larger hole, install the new master.
4. Attach the master cylinder push rod to the pedal with the supplied clevis attachment.
5. Place the proportioning valve bracket onto one of the nuts that holds the master and tighten.
6. Mount the valve to the bracket.
7. Run the two supplied pre-bent lines from the master to the valve.
8. Run hard line from the valve to the front and rear part of the braking system as per the valve diagram.

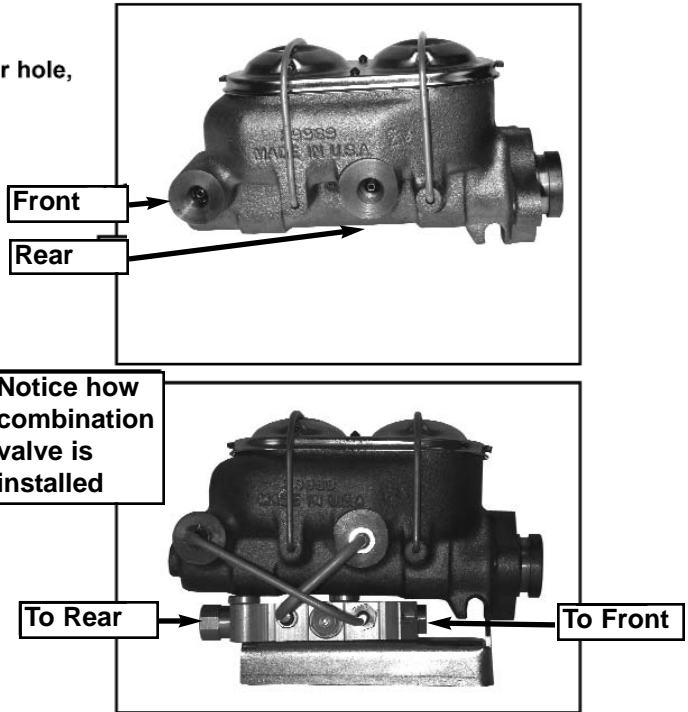

**NOTE:** When running lines to the front, you can plug one of the outlets on the valve (to front) and splice the one brake line to front calipers. You do not need to run two separate lines to the combination valve.

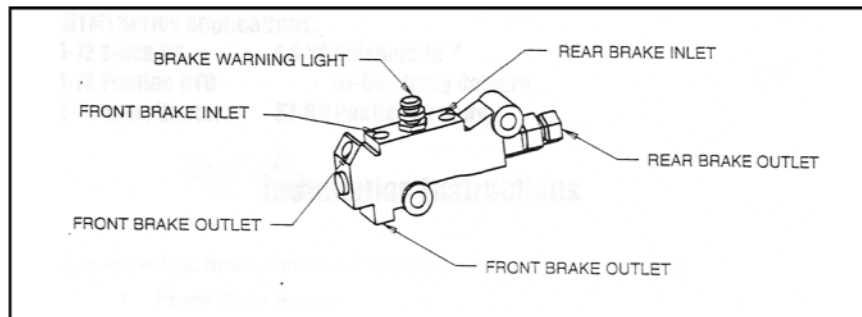

# DB1711M

## DISC BRAKE KIT, MANUAL 55-58 CHEVY

### PARTS LIST

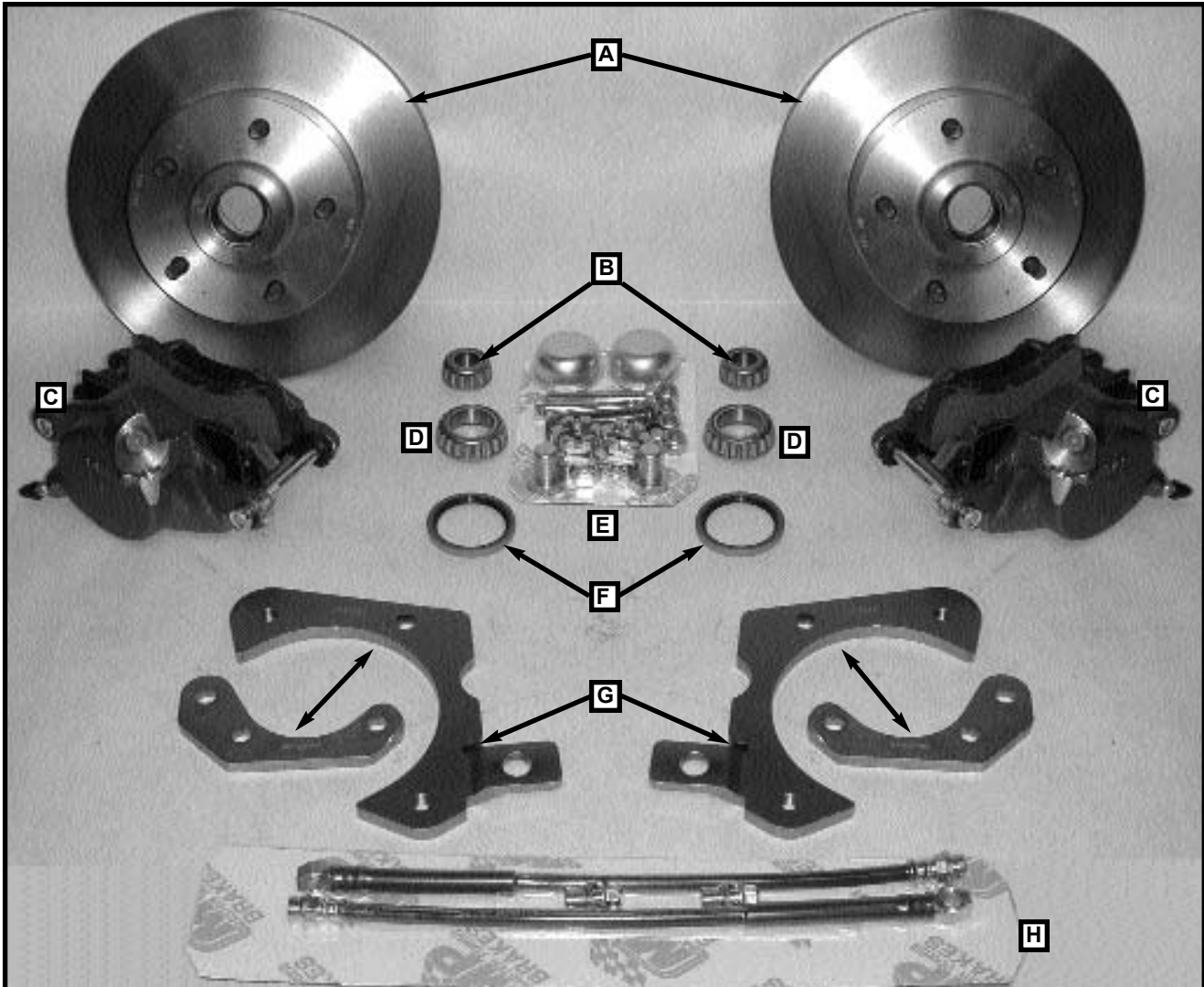

#### PARTS LIST

- A) (2) RT141039 ROTOR, SINGLE PISTON CALIPER 69-72 CHEVELLE, 67-69 CAMARO, 69-74 MONTE CARLO
- B) (2) HWA2 BEARING, OUTER
- C) (2) CA403940 CALIPERS, GM, LARGE, SINGLE PISTON
- D) (2) HWA6 BEARING, INNER
- E) (1) HW1711HK HARDWARE KIT
  - (2) 12R150PCOZ PIN, COTTER, 1/8 X 1 1/2 ZINC
  - (2) 43C225HCS8Y BOLT, 7/16-20 X 2 1/4 HCS GR-8 ZINC YELLOW
  - (2) 43C275HCS8Y BOLT, 7/16-20 X 2 3/4 HCS GR-8 ZINC YELLOW
  - (4) 43CNNEZ 7/16-14 NYLOCK NUT
  - (2) 50F250KBC BOLT, 1/2-20 X 2 1/2 BUT SOC CAP SCREW
  - (2) 50FNNEZ NUT, 1/2-20, NYLOCK, ZINC
  - (2) BU1711 SPACER, CALIPER BKTS, 55-58 CHEVY
  - (2) HW1702 BOLTS, CALIPER BRACKET
  - (2) HW4001 CAPS, DUST, 45.2MM /1 25/
  - (2) HW615005 WAHSER, SPINDLE ORG. GM
  - (2) HW615065M SPINDLE NUT, GM, MODIFIED MACHINED
- F) (2) HW7934 SEAL, ROTOR
- G) (1) BR1711K BRACKET KIT, CALIPER, SINGLE
  - (2) BR1711-2 BRACKET, CALIPER, SMALL DOG BONE SHAPE
  - (1) BR1711L BRACKET, CALIPER LEFT
  - (1) BR1711R BRACKET, CALIPER RIGHT
- H) (1) HS88520K HOSE KIT, FRONT, 69-77, 16"
  - (2) HS88520 HOSE, F, 69-71 CAMARO 16"
  - (2) HW21082 BOLT, HOSE 7/16 X 20 SHORT
  - (4) HW4390 COPPER SEALING WASHER USED W/ 4039 & 4040 CALIPER

**CONTINUED  
ON PAGE 2**

**DB1711M  
CONTINUED**

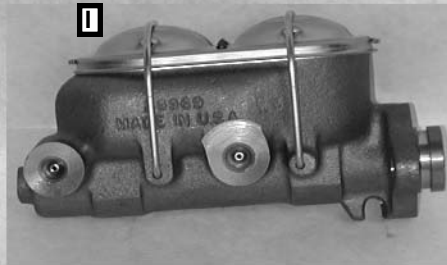

**PARTS LIST**

- I) (1) MC390360M MASTER CYLINDER, GM 1" BORE, 7/16" STROKE  
DUAL RESERVOIR
- J) (1) VL3360K VALVE KIT, W/ FITTINGS
  - (1) 25C175HCS5Z 1/4 X .175 BOLT
  - (1) 25CNNEZ 1/4 COURSE NYLOCK NUT
  - (1) BR1261N BRACKET, VALVE, UNIVERSAL
  - (2) HW105-3 NUT, 3/16 TUBE 3/8-24 THD
  - (1) HW106-3 PLUG, 3/16"
  - (2) HW106-4 PLUG, INVERTED STEEL 1/4" O.D.
  - (1) HW115-37 NUT, 3/16 TUBE 7/16-24 THD RED
  - (1) HW115-38 NUT, 3/16 TUBE 1/2-20 THD BLACK
  - (1) HW115-39 NUT, 3/16 TUBE 9/16-18 THD OLIVE
  - (1) HW1709 PLUG, SWITCH, COMBO VALVE
  - (1) HW210-43 ADAPTOR, BRASS 7/16-3/8M
  - (2) HW300-3 COUPLER 3/16
  - (2) HW300-4 COUPLER 1/4
  - (2) HW300-5 COUPLER 1/2
  - (1) HW3359 PLUG, COMBO VALVE, 4 WHEEL DISC
  - (1) HW702-3 T-FITTING 3/16 X 3/16 X 3/16
  - (1) VL3350 VALVE, COMBO, DISC / DRUM

**MASTER POWER BRAKES 888-533-1199**