



# MASTER POWER BRAKES

110 Crosslake Park Road, Mooresville, NC 28117

Website: [www.mpbrakes.com](http://www.mpbrakes.com)

Technical Support: 888-533-1199

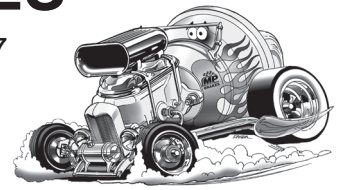

## WARNING

Proper operation of your brakes is essential for your safety and the safety of others. Any brake service should be performed **ONLY** by persons experienced in the installation and proper operation of brake systems. It is the responsibility of the person installing the component or kit for the particular application. After installation and before operating your vehicle, be sure to test the function of the brakes under controlled conditions.

→ **DO NOT DRIVE WITH UNTESTED BRAKES!** ←

FOR TECHNICAL ASSISTANCE CALL:

**888-533-1199**

MONDAY - FRIDAY

8:00 A.M. TO 5:00 P.M. E.S.T.

## CHECK ORDER IMMEDIATELY WARRANTY INFORMATION

Take time to read all the literature that came with this kit. Check the provided list of parts against what you received to ensure all parts are present. While this kit was designed to make the process of changing brake parts as simple as possible, **with some kits it may be necessary to make minor changes to your car.**

***Read all warranty disclaimers and return policies included in this kit prior to installation.***

You have: **5 days** to declare shipping damages  
**30 days** to declare missing or incorrect parts  
**90 days** for exchanges or returns (RA req'd)  
**1 year** before product warranty expires.

*No exceptions allowed.*

*Thank you for your business!*



MASTER POWER BRAKES

110 Crosslake Park Road, Mooresville, NC 28117

Website: [www.mpbrakes.com](http://www.mpbrakes.com) Technical Support: 888-533-1199

© 2006 MP Brakes. All rights reserved. Master Power® is a registered trademark of Master Power Brakes, LLC



## INSTALLATION INSTRUCTIONS

### INCLUDED COMPONENTS

Your power brake conversion kit will contain the following components:

1. Power booster with vacuum hose and intake manifold fitting .
2. Master cylinder
3. Combination valve kit
4. Caliper mounting brackets and hardware
5. Calipers with pads
6. Rotors
7. Bearings, seals and dust caps
8. Caliper hoses
9. Firewall boot and plate.

**IMPORTANT NOTE:  
KIT REQUIRES USE  
OF 1972 OR NEWER  
FULL-SIZE FORD  
DISC BRAKE  
WHEELS**

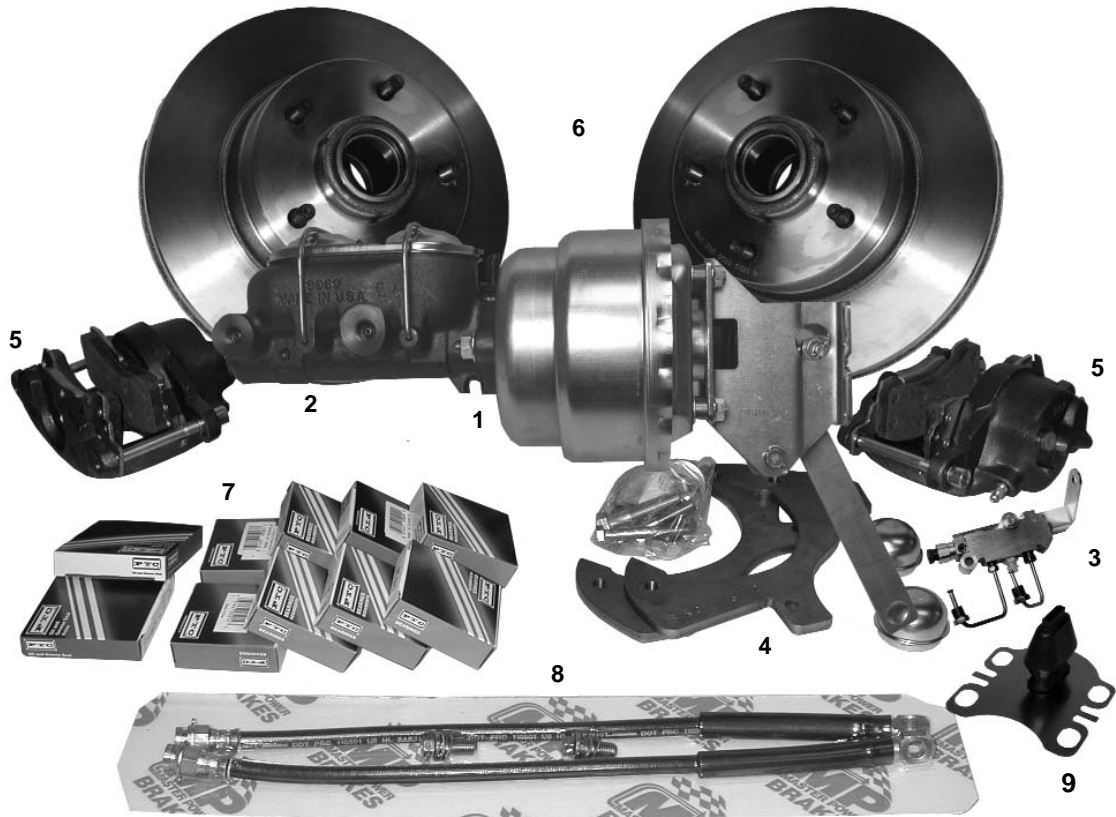

### DISC BRAKE INSTALLATION

Installation of the disc brake kit will require the use of the following tools:

3/8" ratchet drive set  
Box end wrench set  
Pliers  
Line flaring tool

Mallet  
Drum brake tool  
Screwdriver  
Line bending tool

Flare wrench set

Always refer to the vehicle owners manual for the correct torque specifications when installing this kit

1. Remove the stock front drums, brakes and backing plates. Clean and inspect the spindles for cracks or damage. Be sure to thoroughly clean out the threaded hole at the top of the spindle. This is extremely important. Use a non oil based cleaner such as Brake Clean. Clean the threads out with a bottoming tap if necessary.
2. The installation of this disc kit will require some light grinding on the back of the spindle where the lower tab of the caliper bracket bolts to the spindle. See figure below.

**Drivers side**



**Drivers side**



3. Mount the caliper bracket to the spindle as shown using the supplied bolts and nuts.
4. There are two different size spindles possible on your car. Test fit the bearings supplied to determine which inner and outer bearings fit on your spindle. If the spindle diameter is 1.250 you will use the A2 and A6 bearings. If your spindle diameter is 1.375 you will use the A12 and A13 bearings. Using the A2 and A6 bearings will require that you change the races on the rotors with the races supplied with those bearings. Tap the races in the rotor out and install the larger races.

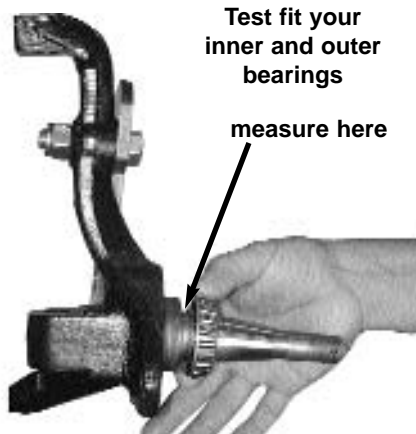

5. Install inner bearing into the rotor followed by the bearing seal. Be careful to tap the seal flush so it is secure in the rotor. Be sure to grease the bearings with bearing grease before installing.

**Installing the inner bearing**



**Installing the inner seal**



6. Install the rotor onto the spindle followed by the outerbearing, keyed washer and spindle nut. Tighten the nut until the rotor does not spin freely and then back off until it spins freely. Be sure to install the cotter pin on the spindle nut.

## GREASE BEARINGS BEFORE INSTALLING WITH A HIGH QUALITY BEARING GREASE

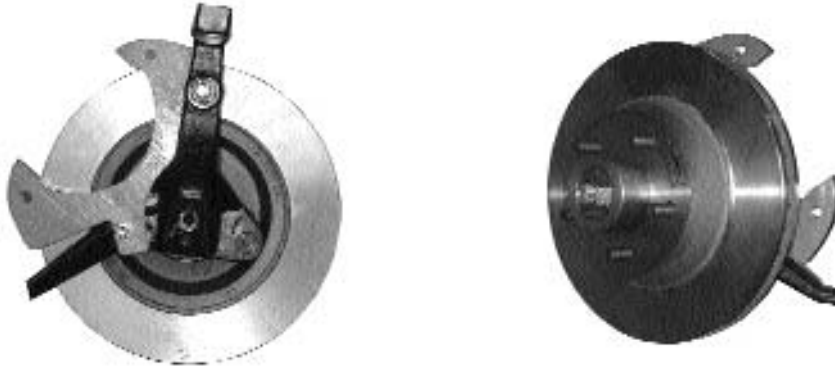

7. Install the pads into the caliper and slide the caliper over the rotor and secure to the bracket with the caliper mounting bolts. **The bleeder screw must up.**

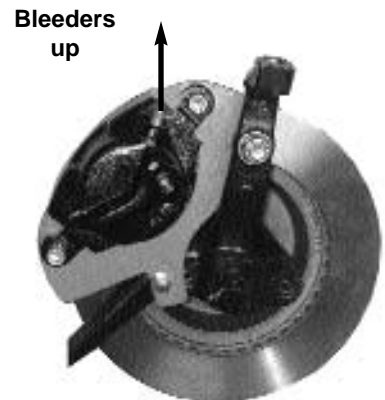
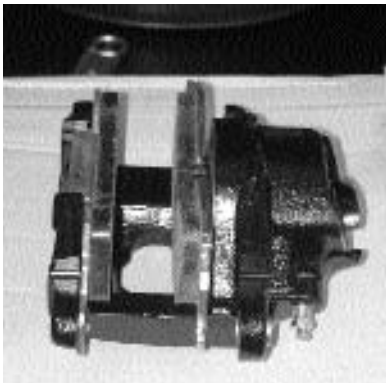

8. Attach the caliper hoses to the calipers using the supplied hose bolts and crush washers. The order of attachment should be caliper, copper washer, brass hose fitting, copper washer, hose bolt.

# BM1507

## Installation Instructions

### WARNING:

Installation of any component or kit should only be performed by persons experienced in the installation and proper operation of brake systems. It is also the responsibility of the person installing any brake component or kit to determine the suitability of the component or kit for that particular application.

### NOTE:

Before operating the vehicle after installation test the function of the brakes under controlled conditions. Make several stops in a safe area from low speed and gradually work up to normal speeds. **DO NOT DRIVE WITH UNTESTED BRAKES!**  
Always utilize safety restraints when operating the vehicle.

### STEP 1:

1. Check to be sure that your kit has all the necessary parts needed to complete this project! (Use the supplied parts list as a check list.)

### STEP 2:

Remove the following components from your car:

**Tech tip:** Prior to disassembly spray the nuts and bolts that you will be removing with a penetrant. (Also disconnect the battery to eliminate the risk of draining the battery or an electrical short.)

1. Disconnect the brake lines to the master cylinder.
2. Next, remove the push rod from the brake pedal.
3. Then remove the old manual master.

### STEP 3:

Things to prepare before assembly of the new booster & master kit.

1. Remove the new master cylinder from the booster assembly.
2. Bench bleed the new master cylinder to remove all the air. If all the air is removed from the master, then it will be difficult to push the piston in.

#### How to bench bleed:

Remove the master from the booster and place in a vice. (Be sure to clamp onto the mounting ear and not the cylinder.)

Install the proper size plugs in the outlet ports of the master.

Fill the master cylinder to the full line with brake fluid.

Use a rounded end rod or a phillips head screw driver and push the piston in repeatedly until no bubbles are visible.

**NOTE: This may take a minute or two of continuous pumping!**

## STEP 4:

### Installation of booster & master components:

1. Install the new booster with bracket to the firewall using the four studs or holes where the original master was located and secure. **(Be sure to place the firewall boot and plate between the booster brackets and the firewall.)**

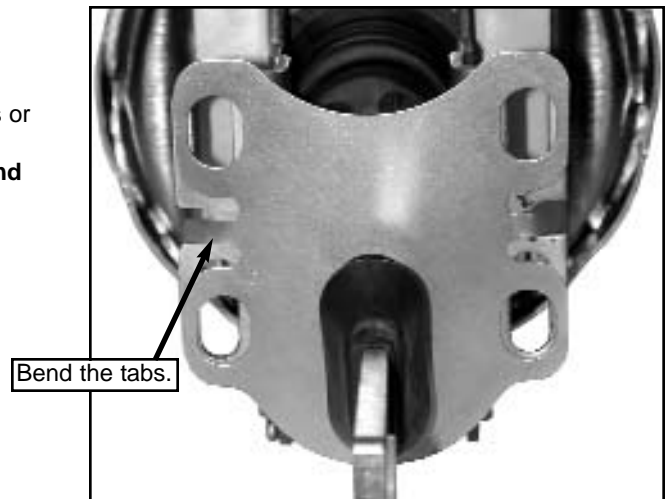

2. Now attach the booster push rod to the original location on the brake pedal using the existing hardware. **(The push rod should attach with no pressure on the pedal.)** Adjust the push rod to have approximately 1/4" free play at the top of the pedal.
3. Mount the master cylinder to the booster. **(Make sure that the master was properly bled.)**

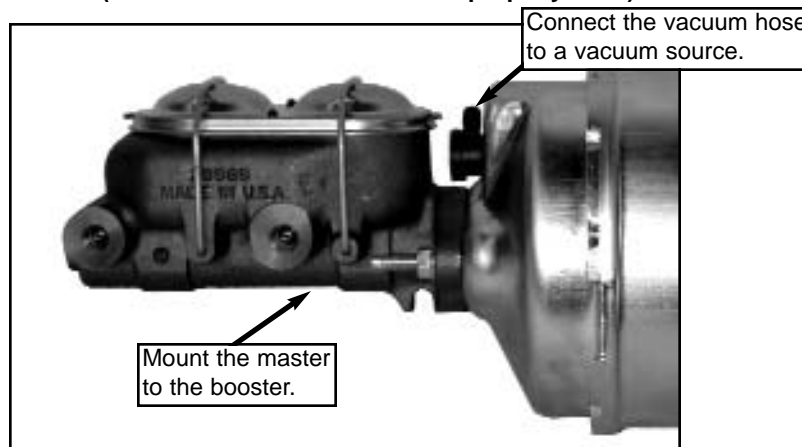

4. Connect the vacuum fitting and the hose to either the intake manifold or to the rear of the carburetor. Make sure that the vacuum source on the carburetor is manifold vacuum and not timed vacuum. **Note: The engine must provide a minimum of 18" of vacuum for the booster to work effectively.**

5. Attach the brake lines to the master. If your kit came with a combination valve go ahead and install it, as per the supplied valve kit instructions. **Note: It is important to remove any factory installed valves from the system. Failure to do so could result in a nonfunctional brake system.**

6. On vehicles which had a single outlet master cylinder you will need to install a new hard line from the proportioning valve outlet to a "T" fitting and then on to the rear wheels. There are two outlets for the front wheels on the combination valve. You have the option of running a line from each wheel to each outlet or running both lines to a "T" fitting and then one line into one of the outlets. **(In this scenario, you will have to plug the unused outlet.)** Either way is acceptable and neither routing has improved braking performance over the other. **(Be sure to keep all lines away from exhaust, steering or other things that could harm them.)**

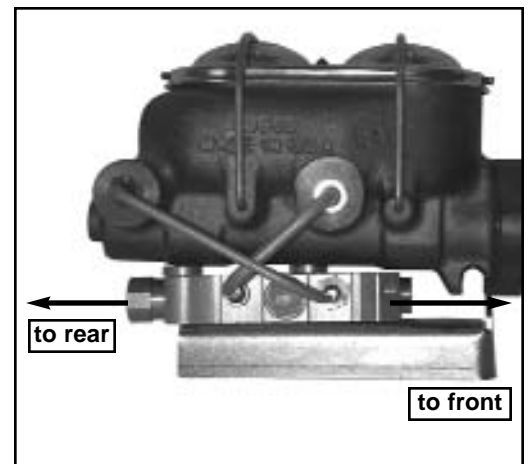

- When the valve is plumbed correctly and all hard lines are attached, bleed the entire system.
- If you are not using a combination valve, or you have four wheel drum brakes, you will need to run one line from the master cylinder to the front and one to the rear. The outlet furthest from the booster will feed the front brakes. We recommend that you use a 10lb residual valve on both the front and rear drum brakes to provide a firmer pedal feel.

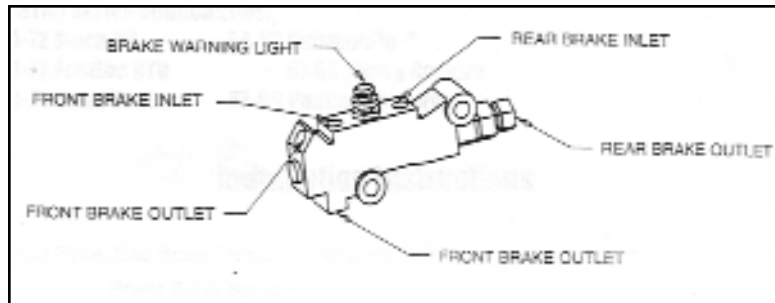

- Reconnect the battery and start the engine. Test the brakes. If the pedal goes to the floor or is very spongy then bleed the system once again.
- Test drive the car in a safe location before driving.

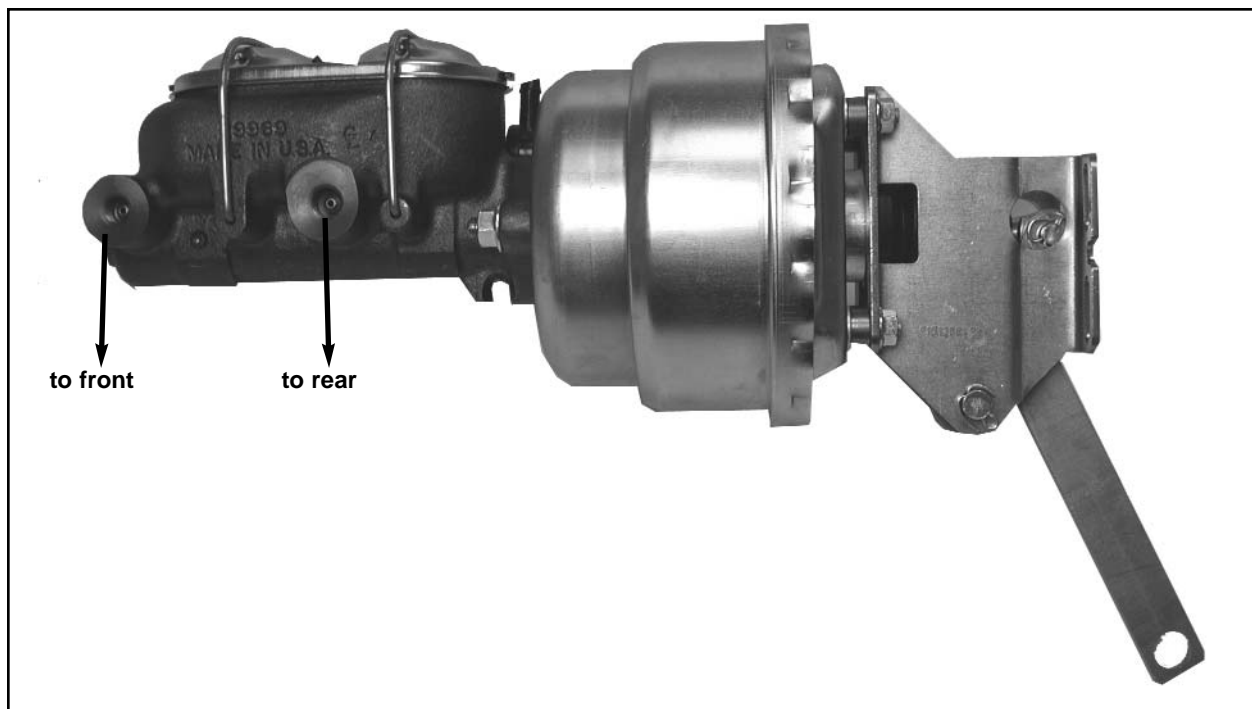

**Master Power Brakes**  
**888-533-1199**

# DB1513P

## DISC KIT, 57-72 F/S FORD POWER

### PARTS LIST

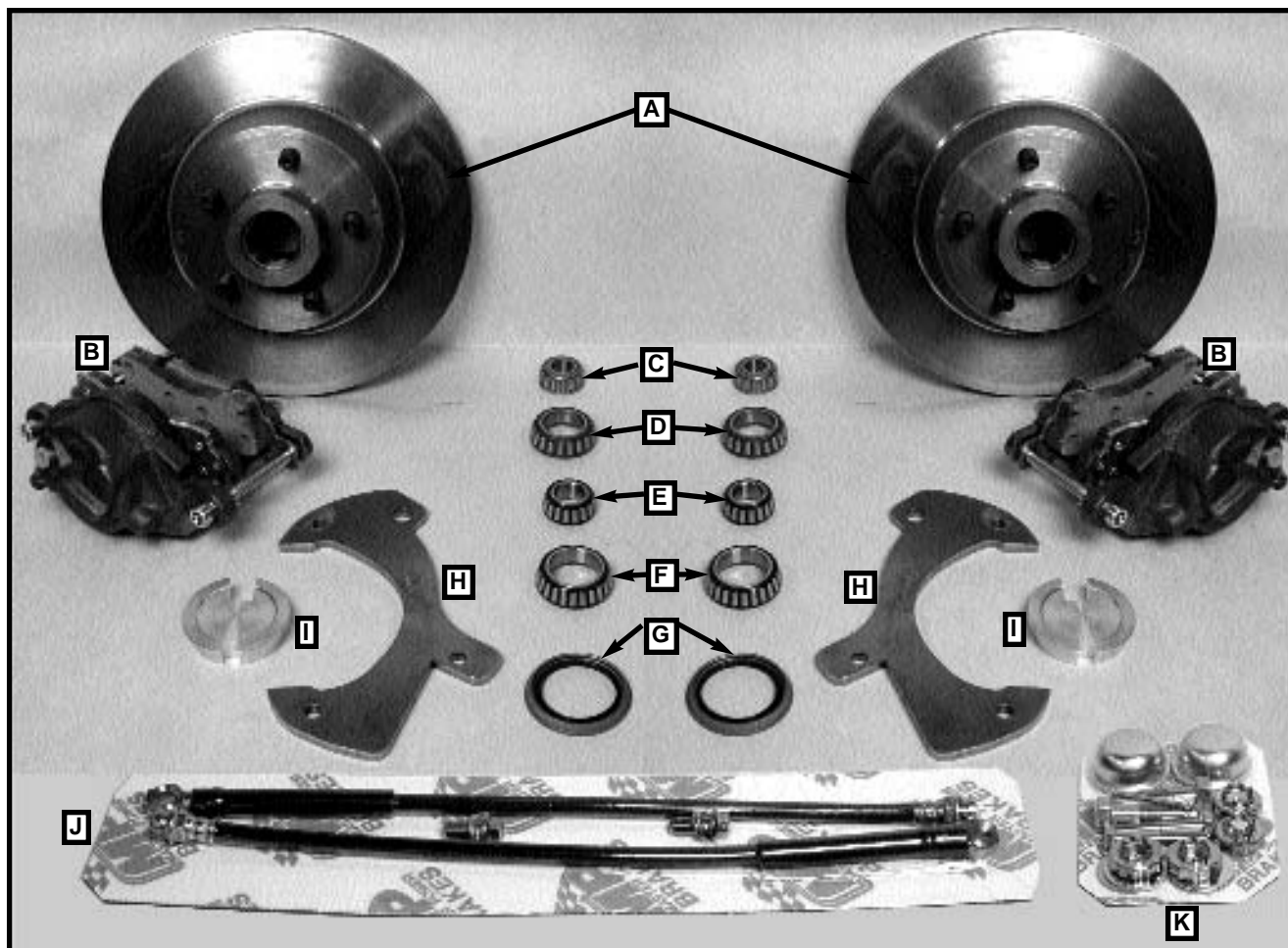

#### PARTS LIST

- A) (2) RT141016 ROTOR, 70-72 FORD
- B) (2) CA404546 CALIPERS, 60-72 CHEVY TRUCK 5 OR 6 LUG PATTERN
- C) (2) HWA2 BEARING, OUTER
- D) (2) HWA6 BEARING, INNER
- E) (2) HWA12 BEARING, OUTER
- F) (2) HWA13 BEARING, INNER
- G) (2) HW6815 SEAL, ROTOR, SEAL
- H) (2) BRCA1512 BRACKET, CALIPER F/S FORD
- I) (2) AD403940 ADAPTOR, PAD OR SPACER FOR MUSTANG II KIT, FORD
- J) (1) HS5157K HOSE KIT, 18" HOSES 10MM  
 (2) HS5157 HOSE, 18" 10MM HOSE  
 (4) HW21206 WASHER, COPPER USED FOR METRIC HOSE BOLT  
 (2) HW5155 10MM METRIC BOLT COURSE
- K) (1) HW1513HK HARDWARE KIT  
 (2) 12R150PCOZ PIN, COTTER, 1/8 X 1 1/2 ZINC  
 (2) 37F225HCS8Y BOLT, 3/8-24 X 2 1/4 HCS GR-8 ZINC  
 (2) 37FNNEZ NUT, 3/8-24 NYLOCK  
 (2) 56F225HCS8Y BOLT, 9/16 X 2 1/4  
 (2) 56FNNEZ 9/16-12 NYLOCK  
 (2) HW4001 CAPS, DUST, 45.2MM /1 25/  
 (2) HW615005 WASHER, SPINDLE ORG. GM  
 (2) HW615072 NUT, SPINDLE  
 (2) HW615073 NUT, SLOTTED  
 (2) HW615074 NUT, SPINDLE  
 (2) HW615075 RETAINER, SPINDLE NUT  
 (2) HW618013 WASHER, SPINDLE NUT

CONTINUED ON  
PAGE 2

L

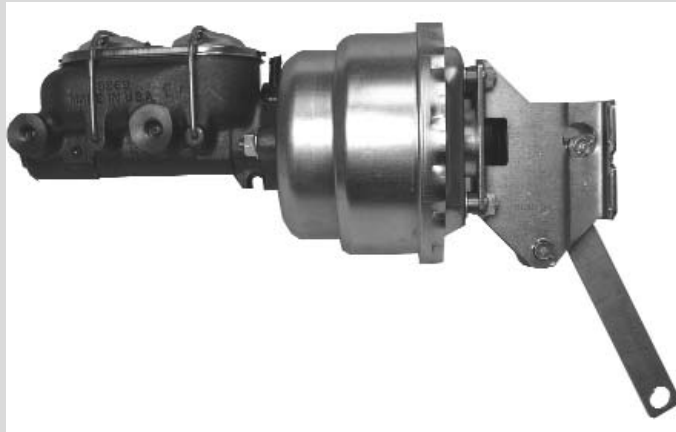

M



#### PARTS LIST

- L) (1) BM1507 BOOSTER, MASTER, FORD 57-72 FULL SIZE 7" BOOSTER (SEE BM1507 PARTS LIST)
- M) (1)(1) VL3360K VALVE KIT, W/ FITTINGS
  - (1) 25C175HCS5Z 1/4 X .175 BOLT
  - (1) 25CNNEZ 1/4 COURSE NYLOCK NUT
  - (1) BR1261N BRACKET, VALVE, UNIVERSAL
  - (2) HW105-3 NUT, 3/16 TUBE 3/8-24 THD
  - (1) HW106-3 PLUG, 3/16"
  - (2) HW106-4 PLUG, INVERTED STEEL 1/4" O.D.
  - (1) HW115-37 NUT, 3/16 TUBE 7/16-24 THD RED
  - (1) HW115-38 NUT, 3/16 TUBE 1/2-20 THD BLACK
  - (1) HW115-39 NUT, 3/16 TUBE 9/16-18 THD OLIVE
  - (1) HW1709 PLUG, SWITCH, COMBO VALVE
  - (1) HW210-43 ADAPTOR, BRASS 7/16-3/8M
  - (2) HW300-3 COUPLER 3/16
  - (2) HW300-4 COUPLER 1/4
  - (2) HW300-5 COUPLER 1/2
  - (1) HW3359 PLUG, COMBO VALVE, 4 WHEEL DISC
  - (1) HW702-3 T-FITTING 3/16 X 3/16 X 3/16
  - (1) VL3350 VALVE, COMBO, DISC / DRUM

**MASTER POWER BRAKES 888-533-1199**