



## WARNING

Proper operation of your brakes is essential for your safety and the safety of others. Any brake service should be performed ONLY by persons experienced in the installation and proper operation of brake systems. It is the responsibility of the person installing any brake component or kit to determine the suitability of the component or kit for the particular application. After installation and before operating your vehicle, be sure to test the function of the brakes under controlled conditions.

**DO NOT DRIVE WITH UNTESTED BRAKES!**

**FOR TECHNICAL ASSISTANCE CALL:**

**888-533-1199**

**MONDAY - FRIDAY**

**8:00 AM TO 5:00 PM EST**

## IMPORTANT

Take time to read all the literature that came with this kit. Check the provided list of parts against what you received to ensure all parts are present. While this kit was designed to make the process of changing brake parts as simple as possible. **NOTE: WITH SOME KITS IT MAY BE NECESSARY TO MAKE MINOR CHANGES TO YOUR CAR!**

**READ ALL WARRANTY DISCLAIMERS AND RETURN POLICIES INCLUDED IN THIS KIT PRIOR TO INSTALLATION!**

**MASTER POWER BRAKES**

**110 CROSSLAKE PARK RD. MOORESVILLE, N.C. 28117**

**[www.mpbrakes.com](http://www.mpbrakes.com)**

## INSTALLATION INSTRUCTIONS

### INCLUDED COMPONENTS

Your power brake conversion kit will contain the following components:

1. Bolt on bracket
2. Thru the floor pedal arm
3. 7" street rod power booster
4. Dual outlet master cylinder

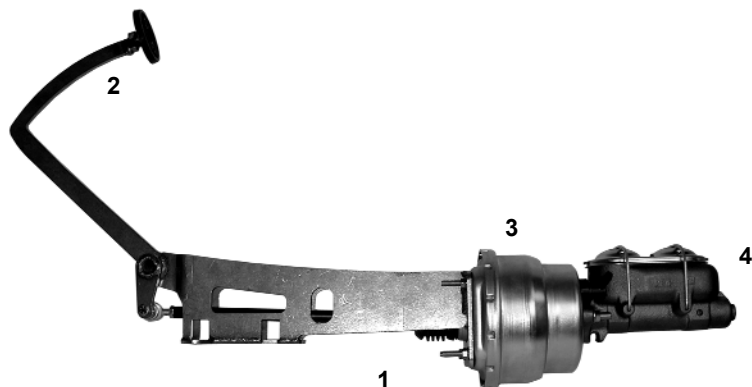

### INSTALLATION

1. Remove the original master cylinder, bracket and brake pedal..
2. Clean the cross member where the bracket will bolt to it.
3. Mount the bracket onto the cross member where the original bracket was located. Use the supplied bolts to mount the bracket keeping the nuts on the top side. Mount the booster to the pedal bracket.

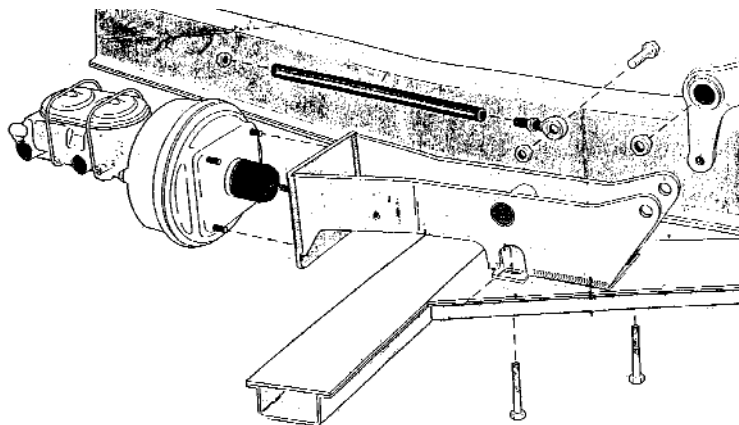

4. Mount the pedal arm to the bracket with the arm coming up through the floor in the original location.
5. Mount the swivel joint and extension rod from the pedal attachment to the threaded end of the booster. Be sure to place the 1/2" steel bushing between the pedal attachment and the swivel joint so the rod lines up directly with the center of the booster. Adjust the rod so there is 1/2" free play at the pedal pad. (no pre load on the booster).

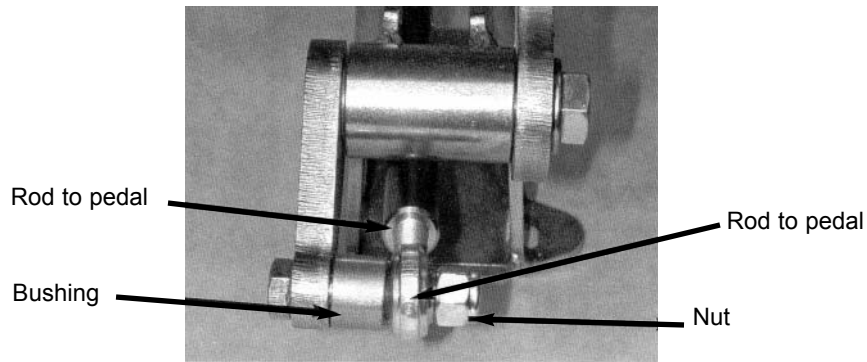

6. A new access door will have to be cut in the floor directly above the new master for cylinder service.
7. Bench bleed the master cylinder to remove all the air.
8. Mount the master cylinder to the booster.
9. Supply the booster with 18" of vacuum from either the back of the carburetor or the intake manifold.
10. Plumb the system as below and then bleed the entire system before driving. Always test drive in a safe area before going on the street

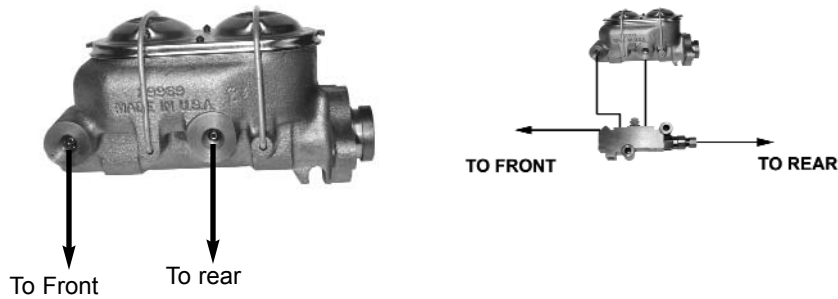

11. If you are our v13350 combination valve, plumb as above.

### WHAT TO DO IF YOU CAN'T GET A BRAKE PEDAL

1. Did you bench bleed the master?
2. Are the front caliper bleeder screws facing up?
3. Is there a 10 lb residual valve to the rear drum brakes?
4. Check the master cylinder by plugging both outlets. If the master is good the pedal will be firm. If the master is bad the pedal will go to the floor.
5. If you have rear calipers the caliper pistons must be adjusted outward so the pads are close to the rotor.

# PA1707 PEDAL ASSEMBLY PARTS LIST 1937-1948 CHEVY

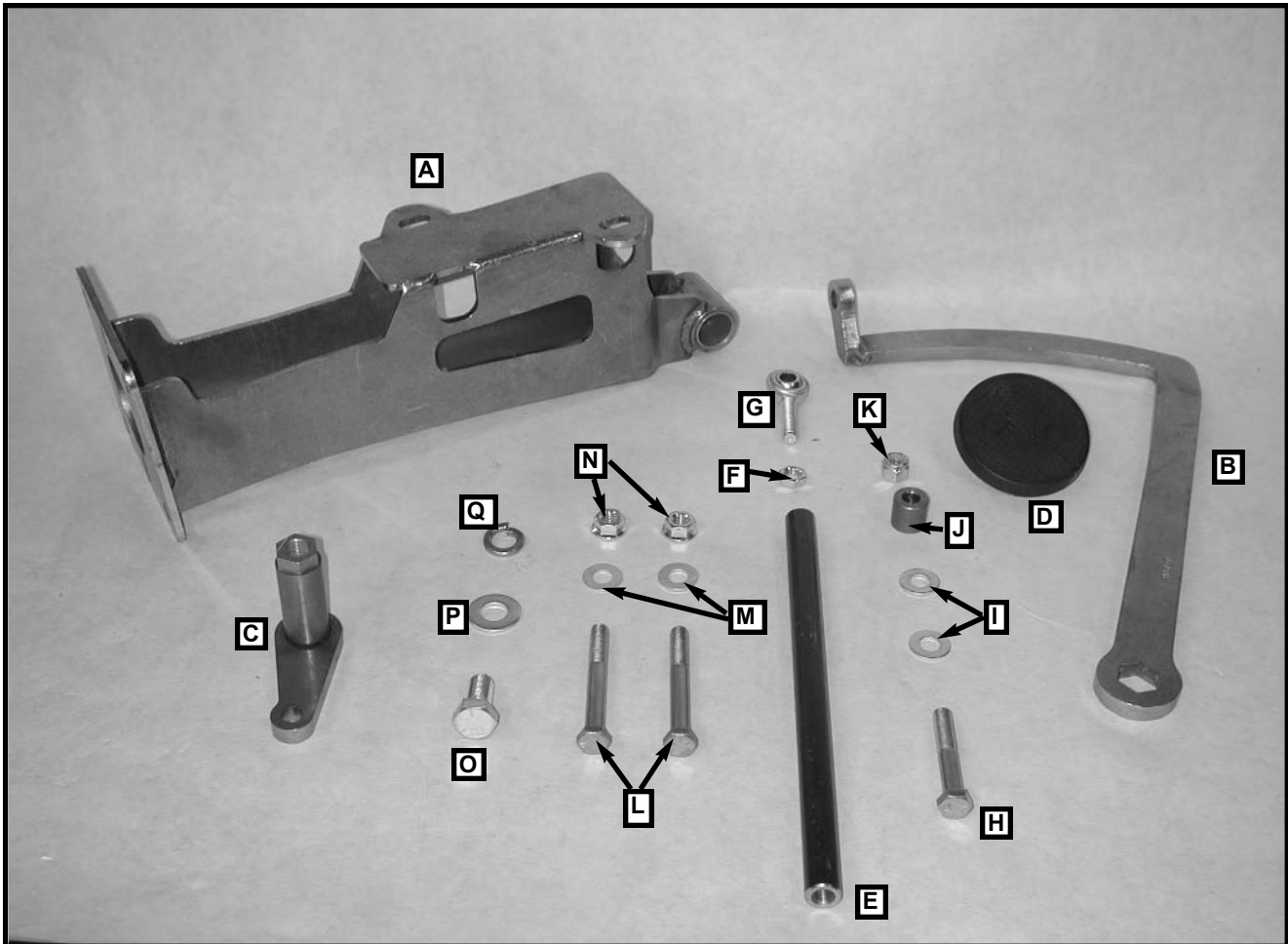

## PARTS LIST

- A) (1) PA1707 PEDAL BRACKET
- B) (1) PA1707 PEDAL ARM
- C) (1) PA1707 PEDAL ARM PIVOT
- D) (1) HW15093 PEDAL PAD
- E) (1) PR1707 PUSH ROD 10" LENGTH
- F) (1) 37FNFJOZ NUT, 3/8-24 HEX FINISH J-NUT ZINC
- G) (1) HW4035 ROD END, MALE 3/8 X 24
- H) (1) 37F225HCS8Y BOLT, 3/8-24 X 2 1/4 HCS GR-8 ZINC
- I) (2) 37NSAEFWZ WASHER, 3/8, FLAT, ZINC GR-5
- J) (1) BU1516 BUSHING, REAR DISC KIT 9" SIZE LENGTH 11/16 X .750, 3/8 HOLE
- K) (1) 37FNNEZ NUT, 3/8-24 NYLOCK
- L) (2) 31C300HCS5Z BOLT, 3" GR-5 ZINC
- M) (2) 31NWUSZ 5/16 USS FLAT WASHER
- N) (2) 31CNWFZ 5/16-18 WHIZ FLANGE NUT
- O) (1) 50F100HCS5Z 1/2-20 X 1 GR-5 HCS ZINC
- P) (1) 50NWSAIY FLAT WASHER, 1/2 SAE
- Q) (1) 50NLOC8Y WASHER, LOCK, 1/2 SPLIT YELLOW ZINC

**MASTER POWER BRAKES 888-533-1199**

Revised 9/29/03