



WARNING

Proper operation of your brakes is essential for your safety and the safety of others. Any brake service should be performed ONLY by persons experienced in the installation and proper operation of brake systems. It is the responsibility of the person installing any brake component or kit to determine the suitability of the component or kit for the particular application. After installation and before operating your vehicle, be sure to test the function of the brakes under controlled conditions.

DO NOT DRIVE WITH UNTESTED BRAKES!

FOR TECHNICAL ASSISTANCE CALL:

888-533-1199

MONDAY - FRIDAY

8:00 AM TO 5:00 PM EST

IMPORTANT

Take time to read all the literature that came with this kit. Check the provided list of parts against what you received to ensure all parts are present. While this kit was designed to make the process of changing brake parts as simple as possible. **NOTE: WITH SOME KITS IT MAY BE NECESSARY TO MAKE MINOR CHANGES TO YOUR CAR!**

READ ALL WARRANTY DISCLAIMERS AND RETURN POLICIES INCLUDED IN THIS KIT PRIOR TO INSTALLATION!

MASTER POWER BRAKES

110 CROSSLAKE PARK RD. MOORESVILLE, N.C. 28117

www.mpbrakes.com



PA1705KP

1940 - 1948 Chevrolet Power Brake Pedal Kit

INSTALLATION INSTRUCTIONS



For use without original K-member only
36-54 Chevy car instructions for brake pedal
Master cylinder / Power booster mount kit

Installation:

1. Remove original pedal / master cylinder. Slide new mount over rail and mark top outside hole.
2. Clamp securely to frame and install pedal arm (**floor hole will need to be enlarged**) and check the clearance. Mount may be moved forward and pedal arm may be heated and bent as needed for your application.
3. Mark and drill lower inner lip and install bolts tightly. Mark and drill upper holes through frame rail.
4. Install the master cylinder and adjust linkage rod with a slight amount of end play to cylinder.
5. Or if mounting a booster and master then install and adjust the linkage from the pedal to booster.
6. Tighten all bolts and grease pedal pivot bolt. Hook up booster vacuum to the engine and bleed the brakes properly. We recommend using DOT 4 fluid for a long lasting system.

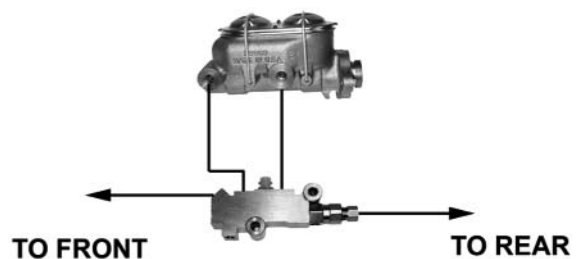

1936 Chevrolet Standard

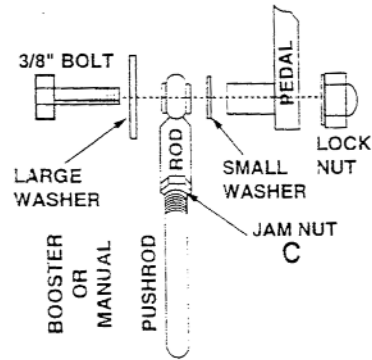
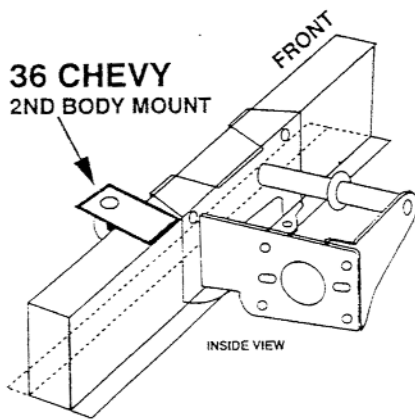
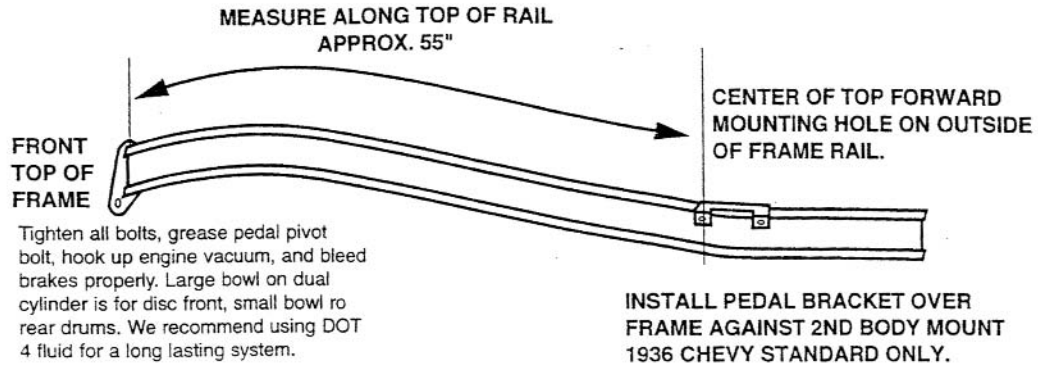

1937-39 Chev Passenger

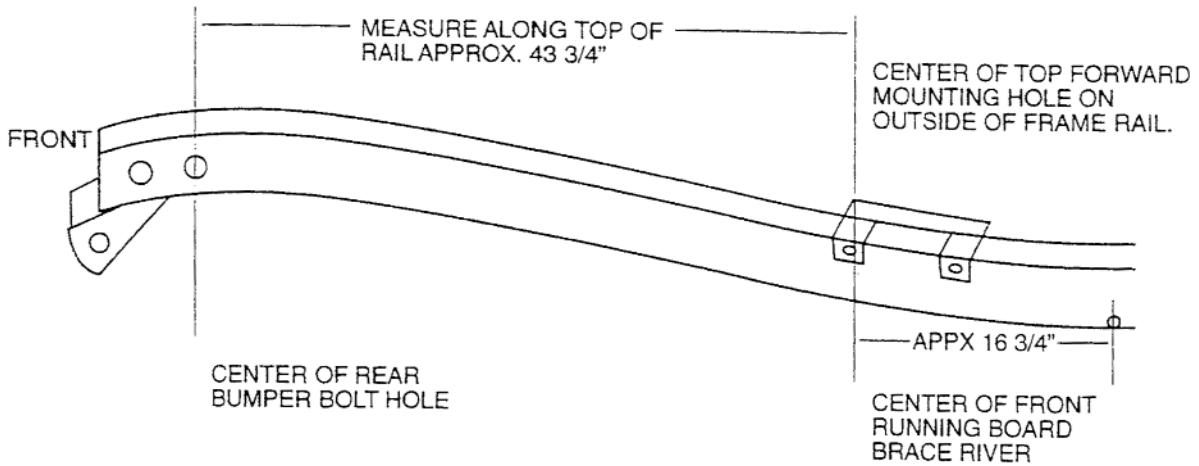

MASTER POWER BRAKES

110 CROSSLAKE PARK RD MOORESVILLE N.C. 28117

www.mpbrakes.com 888-533-1199



PA1705 PEDAL ASSEMBLY PARTS LIST

1940-1948 CHEVY

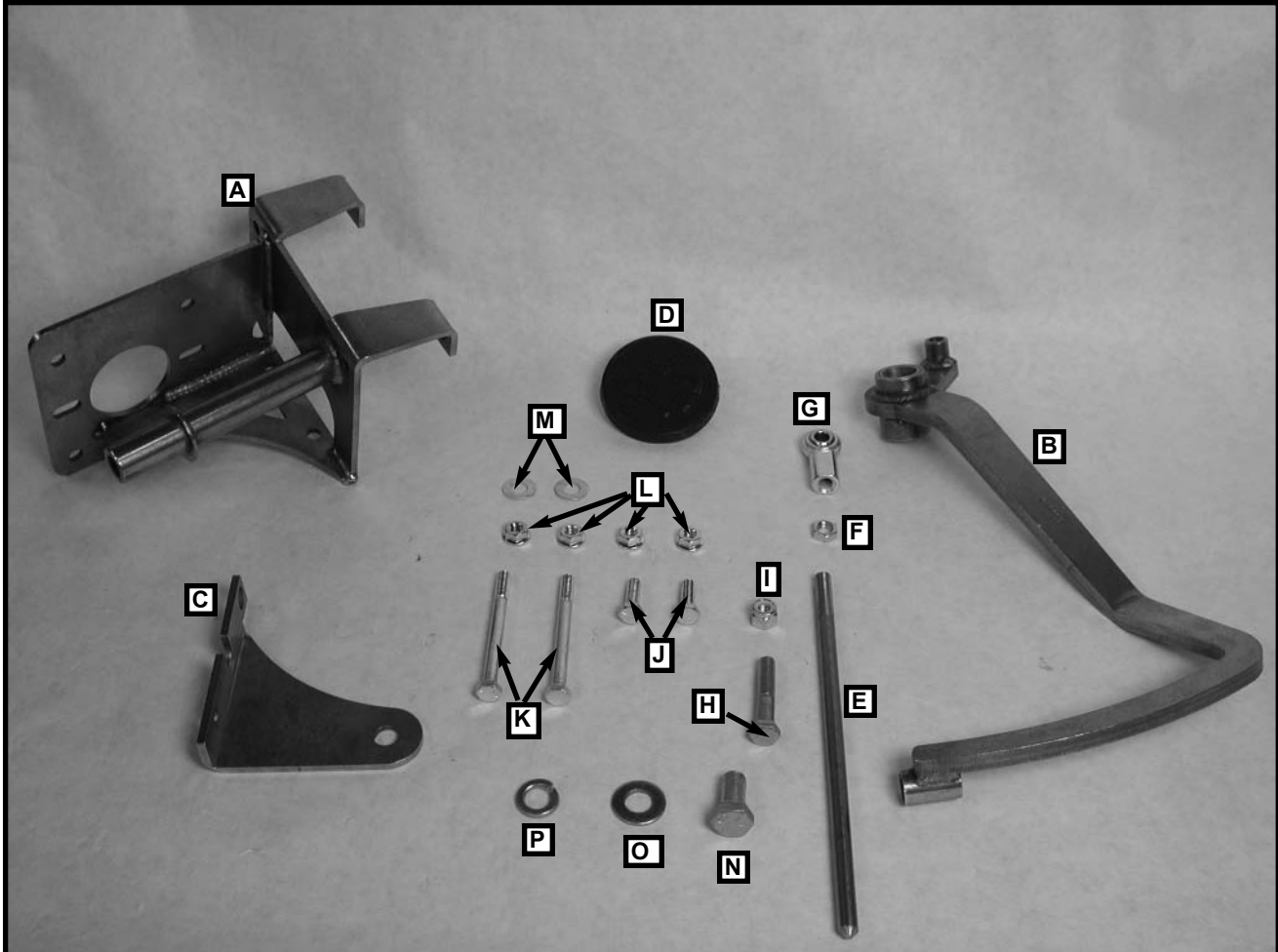

PARTS LIST

- A) (1) PA1705 PEDAL BRACKET
- B) (1) PA1705 PEDAL ARM
- C) (1) PA1705 SUPPORT BRACKET
- D) (1) HW15093 PEDAL PAD
- E) (1) PR4721 ROD, 9-3/8 X 3/8-24 THREAD END
- F) (1) 37FNFJOZ NUT, 3/8-24 HEX FINISH J-NUT ZINC
- G) (1) HW4034 ROD END, FEMALE 3/8-24
- H) (1) 37F200HCS5Z 3/8-24 X 2 GR-5 HCS ZINC
- I) (1) 37FNNEZ NUT, 3/8-24 NYLOCK
- J) (2) 31C100HCS5Z BOLT, 3/8 X 16 X 1"
- K) (2) 31C300HCS5Z BOLT, 3" GR-5 ZINC
- L) (4) 31CNWFZ 5/16-18 WHIZ FLANGE NUT
- M) (2) 37NSAEFWZ WASHER, 3/8, FLAT, ZINC, GR-5
- N) (1) 50F100HCS5Z 1/2-20 X 1 GR-5 HCS ZINC
- O) (1) 50NSAEFWY FLAT WASHER 1/2 SAE
- P) (1) 50NLOC8Y WASHER, LOCK, 1/2 SPLIT YELLOW ZINC