



## WARNING

Proper operation of your brakes is essential for your safety and the safety of others. Any brake service should be performed ONLY by persons experienced in the installation and proper operation of brake systems. It is the responsibility of the person installing any brake component or kit to determine the suitability of the component or kit for the particular application. After installation and before operating your vehicle, be sure to test the function of the brakes under controlled conditions.

**DO NOT DRIVE WITH UNTESTED BRAKES!**

**FOR TECHNICAL ASSISTANCE CALL:**

**888-533-1199**

**MONDAY - FRIDAY**

**8:00 AM TO 5:00 PM EST**

## IMPORTANT

Take time to read all the literature that came with this kit. Check the provided list of parts against what you received to ensure all parts are present. While this kit was designed to make the process of changing brake parts as simple as possible. **NOTE: WITH SOME KITS IT MAY BE NECESSARY TO MAKE MINOR CHANGES TO YOUR CAR!**

**READ ALL WARRANTY DISCLAIMERS AND RETURN POLICIES INCLUDED IN THIS KIT PRIOR TO INSTALLATION!**

**MASTER POWER BRAKES**

**110 CROSSLAKE PARK RD. MOORESVILLE, N.C. 28117**

**[www.mpbrakes.com](http://www.mpbrakes.com)**

# PA1506KPO

1949-1951 Ford Power Brakes  
For Automatic or Manual Transmission

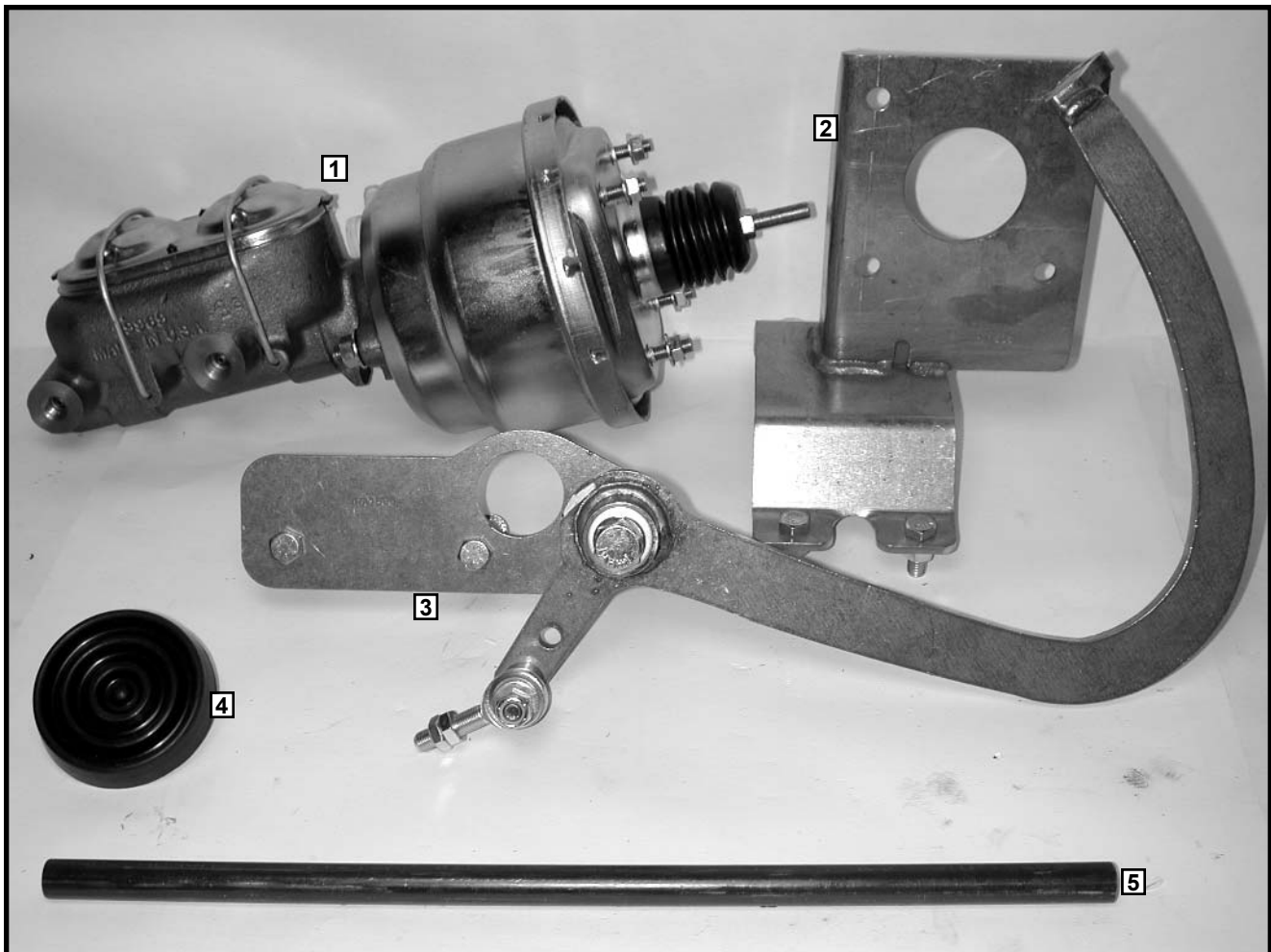

**Parts included in the box:**

1. (1) Booster and master unit.
2. (1) Booster mounting frame bracket.
3. (1) Pedal assembly with hardware.
4. (1) Pedal pad.
5. (1) Push rod.

**Master Power Brakes**  
**888-533-1199**

# PA1506KPO

## Installation Instructions

### WARNING:

Installation of any component or kit should only be performed by persons experienced in the installation and proper operation of brake systems. It is also the responsibility of the person installing any brake component or kit to determine the suitability of the component or kit for that particular application.

### NOTE:

Before operating the vehicle after installation test the function of the brakes under controlled conditions. Make several stops in a safe area from low speed and gradually work up to normal speeds. **DO NOT DRIVE WITH UNTESTED BRAKES!**

Always utilize safety restraints when operating the vehicle.

### STEP 1:

1. Check to be sure that your kit has all the necessary parts needed to complete this project! (Use the supplied parts list as a check list.)

### STEP 2:

Remove the following components from your car:

**Tech tip:** Prior to disassembly spray the nuts and bolts that you will be removing with a penetrant. (Also disconnect the battery to eliminate the risk of draining the battery or an electrical short.)

1. Disconnect the brake line to the master cylinder.
2. Then, disconnect the bolts that hold the old manual master cylinder to the frame and remove.
3. Now you should be able to remove the old master unit with the pedal still attached.

### STEP 3:

Things to prepare before assembly of the new booster & master with pedal kit:

1. Bench bleed the new master cylinder to remove all the air. If all the air is removed from the master, then it will be difficult to push the piston in.

#### How to bench bleed:

Remove the master from the booster and place in a vice. (Be sure to clamp onto the mounting ear and not the cylinder.)

Install the proper size plugs in the outlet ports of the master.

Fill the master cylinder to the full line with brake fluid.

Use a rounded end rod or a phillips head screw driver and push the piston in repeatedly until no bubbles are visible.

**NOTE: This may take a minute or two of continuous pumping!**

2. Next, clamp the new booster mounting plate to frame rail, directly behind the cross member. Make sure that the mounting plate is also up against the cross member.
3. Use the plate as template and mark where the holes are on the frame. Remove the mounting plate and drill holes through the inner side rail, using a long 3/8" drill bit.
4. Now using the inner frame holes as a guide, drill the holes through the outer frame rail. On the outer frame rail you will need to open up the outer holes for socket clearance, about 1", to tighten the nuts on the mounting bolts.

## STEP 4:

### Installation of booster, master & pedal components:

1. Now mount the booster mounting plate to the inner frame rail and secure by tightening the mounting bolts.
2. Bolt the booster to the booster mounting plate and secure tightly.

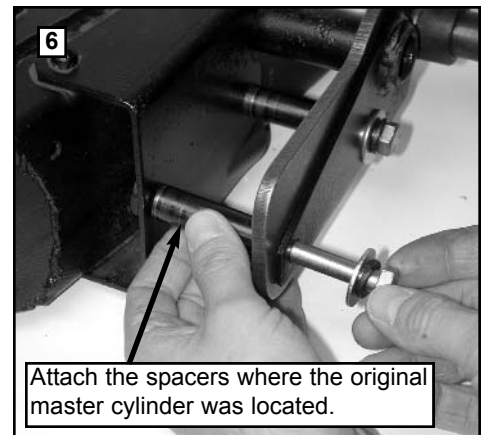
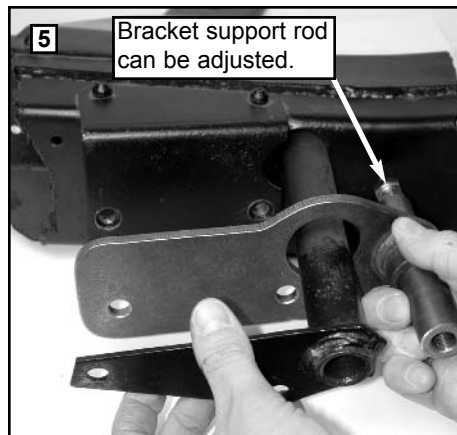
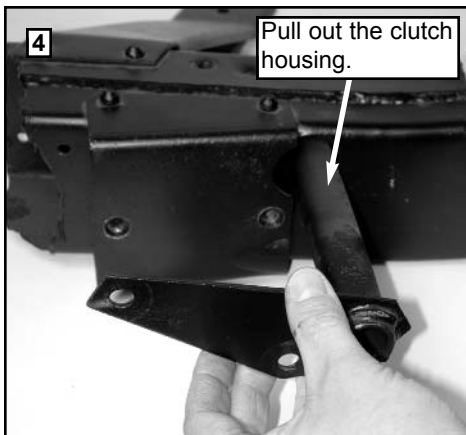
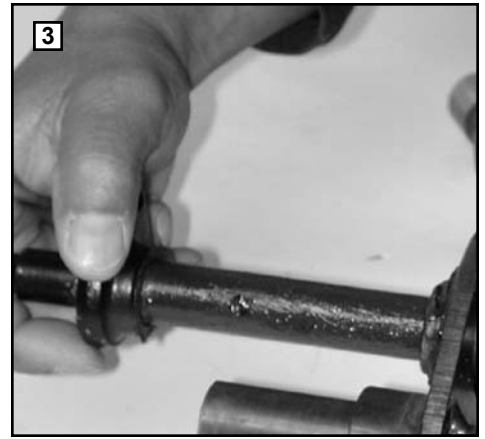
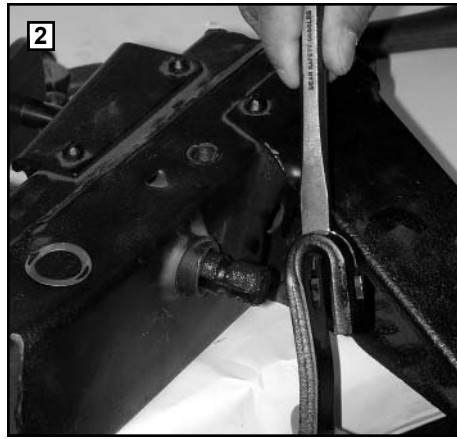
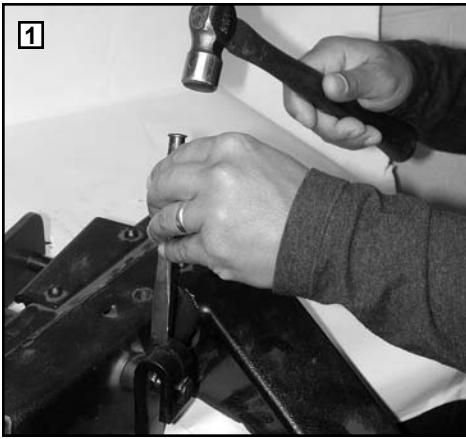

3. Remove the clutch pedal (as shown in pictures 1 & 2) and then slide the clutch linkage rod out of the clutch housing (picture 3).
4. Now pull the clutch housing out of the frame (picture 4).
5. Install the pedal bracket by running the clutch housing through the hole in the bracket and then through the frame (picture 5).
6. Using the provided spacers and long bolts, attach the new pedal bracket and the clutch housing to the frame in the same location as the original master cylinder (picture 6).
7. Reinstall the clutch linkage rod followed by the clutch pedal. (NOTE: If you are going to an automatic transmission, it is not necessary to install the clutch linkage rod and the clutch pedal.)

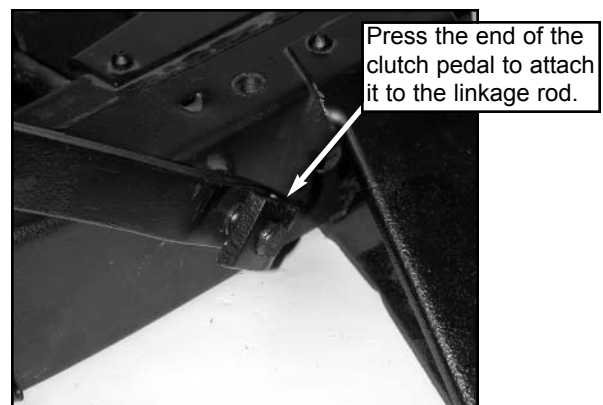

8. Now install the new brake pedal onto the pedal bracket using the supplied washer and bolt.

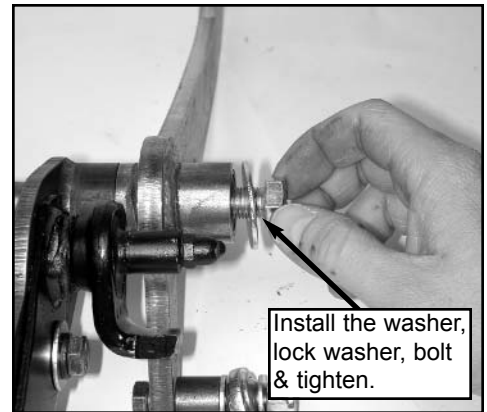
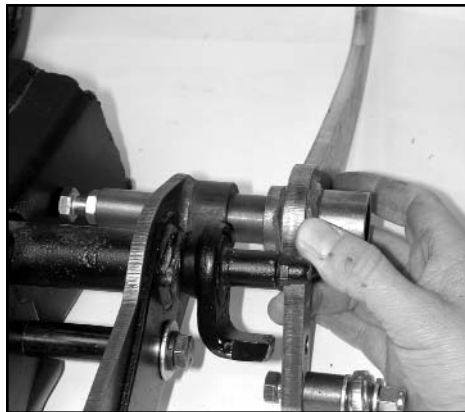

9. Attach the push rod linkage to the pedal then to the booster. (You may adjust the push rod to suit your pedal requirements.)

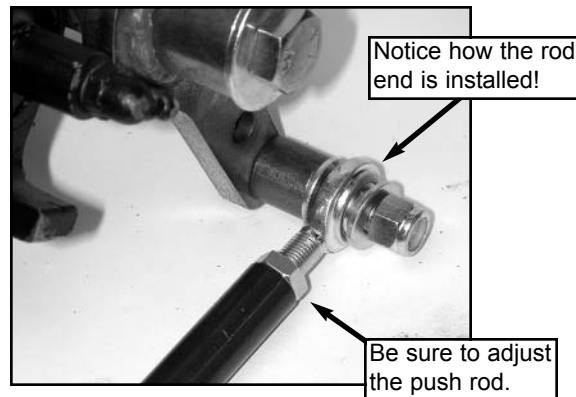

10. Mount the new master cylinder to the booster. (Make sure the the master was properly bled.)

11. Connect the vacuum fitting and the hose to either the intake manifold or to the rear of the carburetor. Make sure that the vacuum source on the carburetor is manifold vacuum and not timed vacuum. (Note: The engine must provide a minimum of 18" of vacuum for the booster to work effectively.)

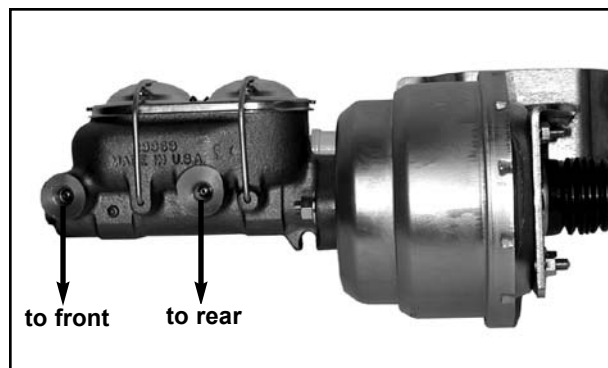

12. Now attach the brake lines to the master cylinder. (If your brake kit came with a combination valve then it is important that you remove any factory installed valves from your system. Failure to do this could result in a nonfunctional brake system.) Then install the combination valve.

13. Run the rear line to the rear outlet on the combination valve. There are two outlets for the front wheels on the combination valve. You have the option of running a line from each outlet or running both lines to a T-fitting and then into one of the front outlets. (In this scenario, you will have to plug the unused outlet.) Either way is acceptable and neither routing has improved braking performance over the other. (Be sure to keep all lines away from exhaust, steering or other things that could harm them.)

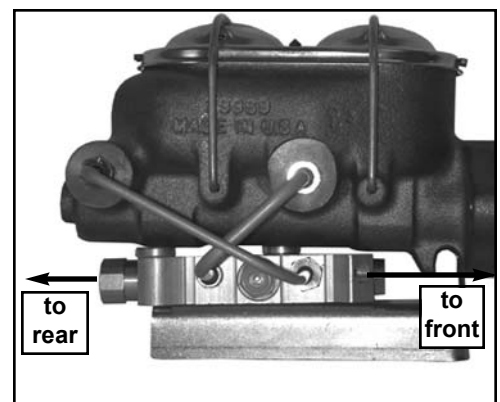
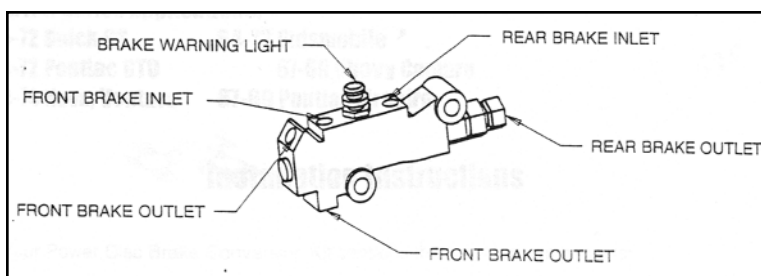

14. When the valve is plumbed correctly and all hard lines are attached, bleed the entire system to remove any air in the lines.
15. If you are not using a combination valve and you have four wheel drum brakes, you will need to run one line from the master cylinder to the front and one to the rear. The outlet closest to the booster will feed the rear brakes. We recommend that you use a 10lb residual valve on both the front and rear drum brakes to provide a firmer pedal feel.
16. Reconnect the battery and start the engine. Test the brakes. If the pedal goes to the floor or is very spongy then bleed the system once again.
17. Test drive the car in a safe location before driving.

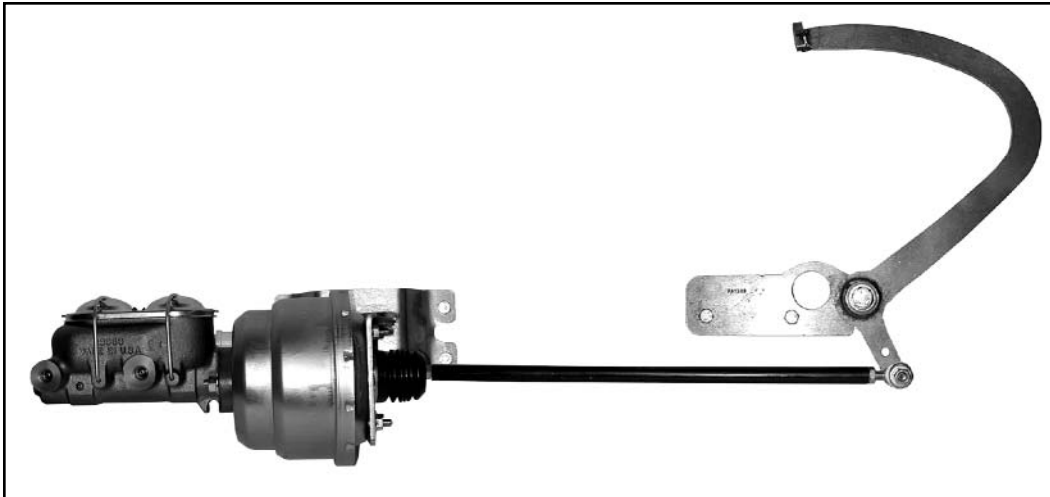

**MASTER POWER BRAKES**  
**888-533-1199**