



PA1504KPO 1935-40 FORD POWER BRAKES

IT'S MORE THAN BRAKES...IT'S CONFIDENCE!

INSTALLATION INSTRUCTIONS



MASTER POWER BRAKES

110 CROSSLAKE PARK RD MOORESVILLE N.C. 28117

www.mpbrakes.com 704-664-8866



REVISED 11/1/05

INSTALLATION INSTRUCTIONS

INCLUDED COMPONENTS

Your power brake conversion kit will contain the following components:

1. Bolt on bracket and pedal
2. 7" power booster
3. Dual outlet master cylinder
4. Bleeder kit (not shown)

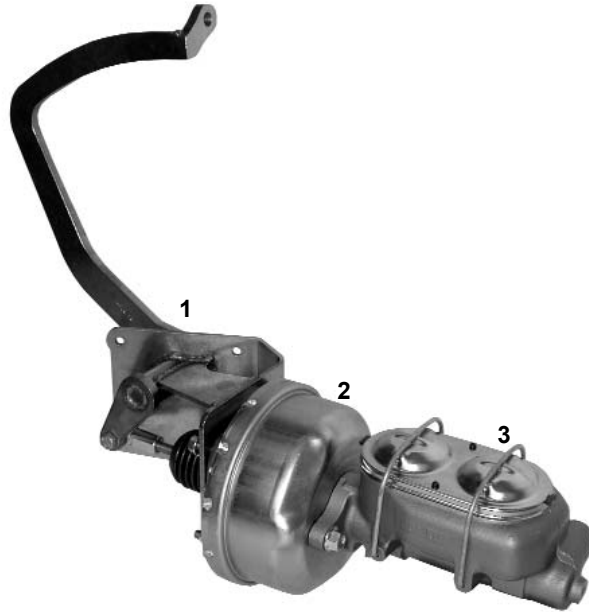

INSTALLATION

1. The installation of this pedal kit will require some minor cutting and drilling of the frame rail.
2. Remove all the old braking components from the frame.
3. Using the supplied template line up the holes with the holes in the frame. The top of the template should be parallel with the top of the X member. Mark and cut out any excess material on the frame.
4. If necessary drill two new 5/16" holes.
5. You should now be able to bolt the pedal assembly to the X member with 4 bolts.
6. Mount the power booster to the pedal assembly and secure with the 4 supplied nuts.
7. Supply the booster with 18" vacuum from either the intake manifold or the back of the carburetor. Be sure to use vacuum hose or hard tubing for the vacuum...non collapsable.
8. Bench bleed the master cylinder to remove all air.
9. Mount the master to the booster and attach the lines as necessary.

If you have disc brakes you will require a combination valve to balance the system.

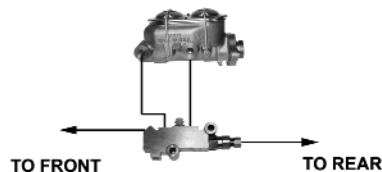

This is the recommended set up for an under floor disc/drum braking system. This system uses a VL3350 combination valve and a VL3702 two lb residual valve to the front.

10. Bleed the entire system. Test the brakes in a safe area before driving the vehicle. If pedal is spongy re bleed system.

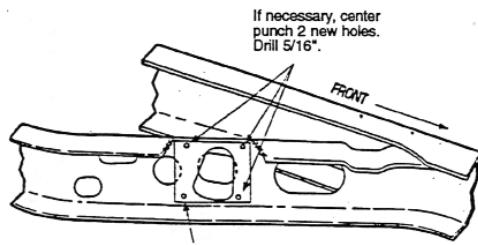

If necessary, center punch 2 new holes. Drill 5/16".

Line up holes in the paper template with the holes in the frame. Top of template should be parallel with top of x-member. Mark and cut out excess metal that is not covered by template.

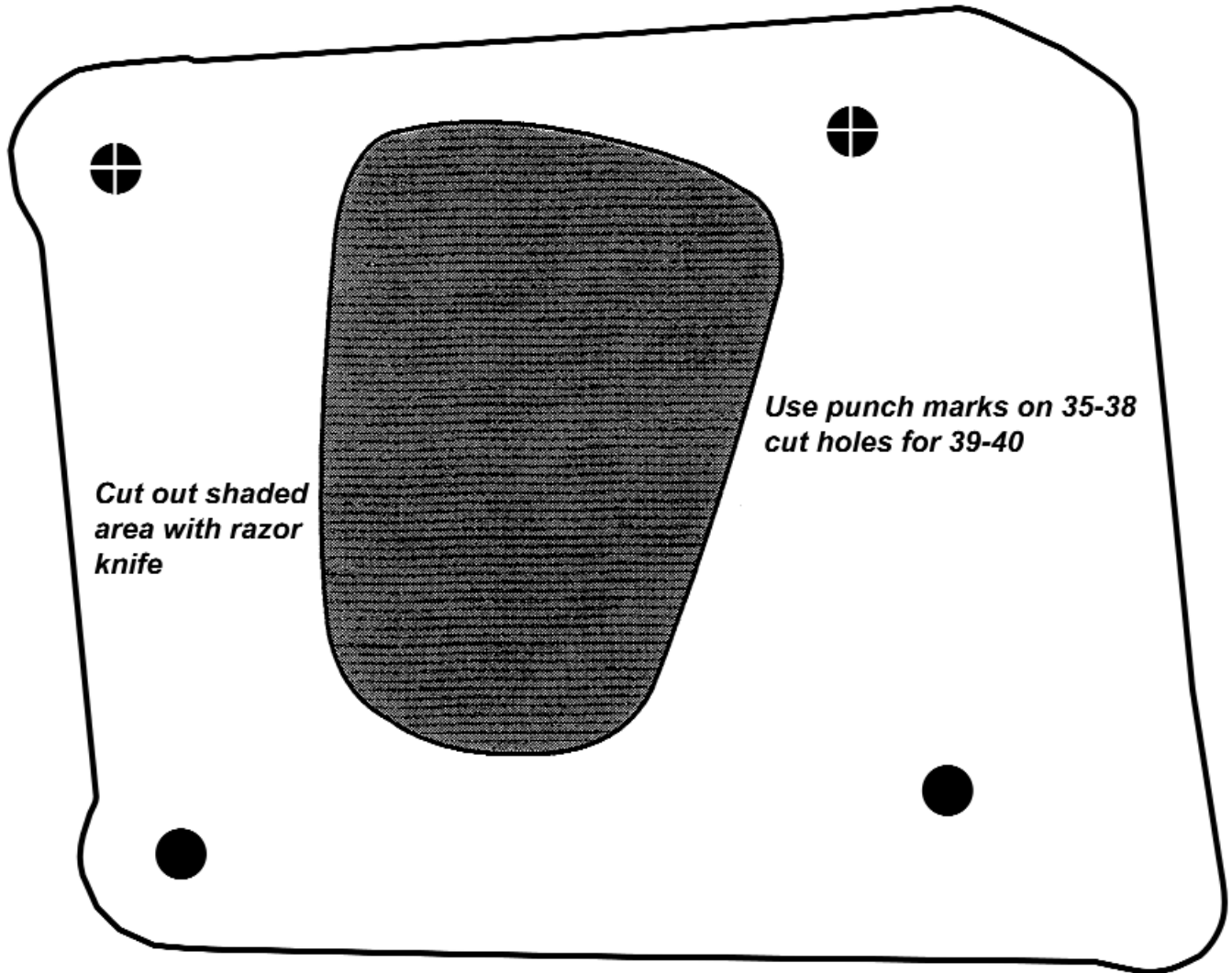
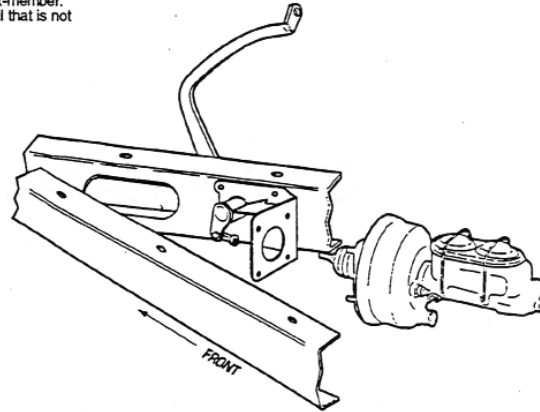

Cut out shaded area with razor knife

Use punch marks on 35-38 cut holes for 39-40

PA1504 PEDAL ASSEMBLY PARTS LIST

1935-1940 FORD

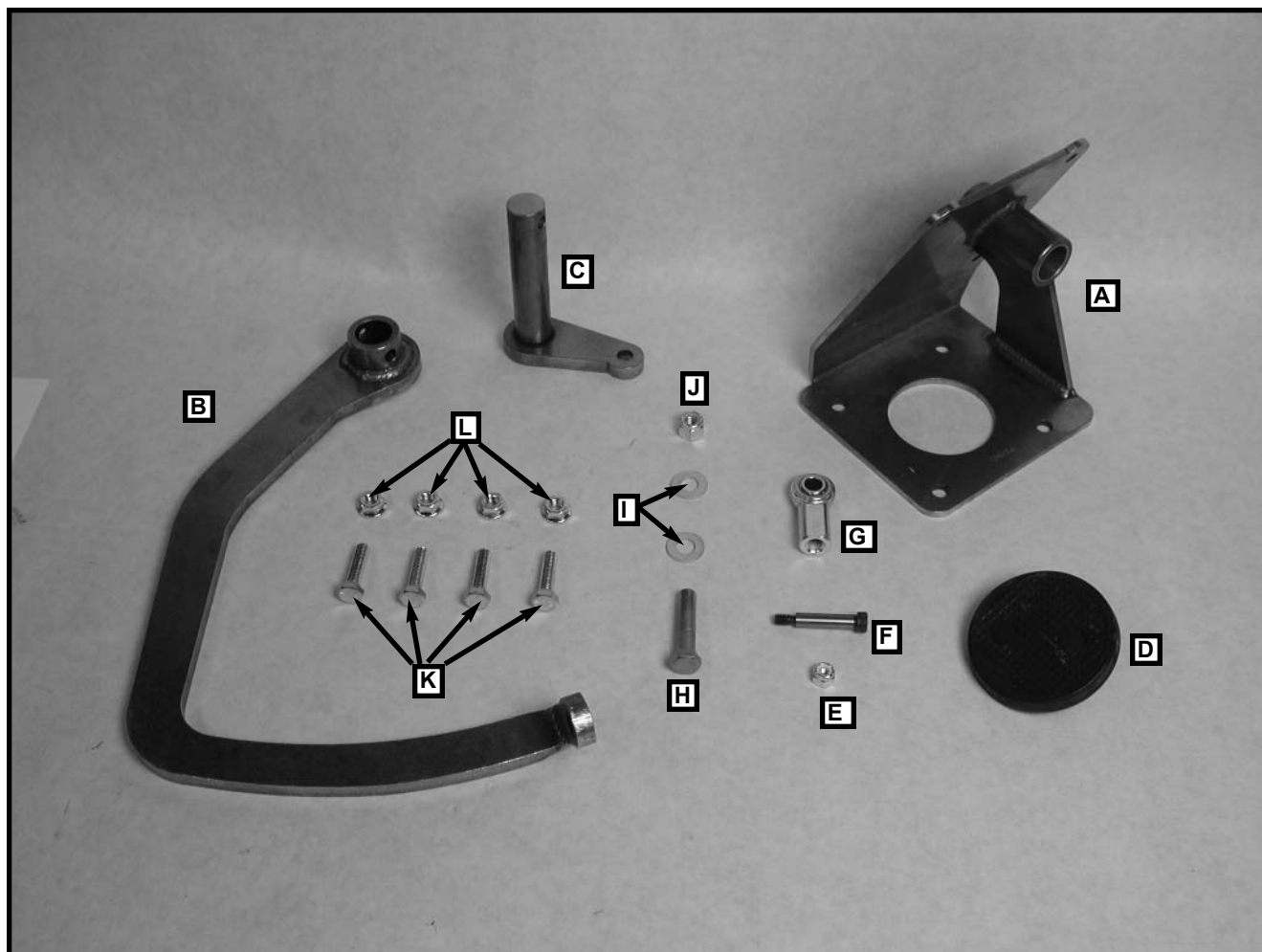

PARTS LIST

- A) (1) PA1504 PEDAL BRACKET
- B) (1) PA1504 PEDAL ARM
- C) (1) PA1504 PEDAL ARM PIVOT
- D) (1) HW15093 PEDAL PAD
- E) (1) 25CNNEZ 1/4 COURSE NYLOCK NUT
- F) (1) 31C125SB 5/16 X 1 1/4 SHOULDER BOLT
- G) (1) HW4034 ROD END, FEMALE, 3/8-24
- H) (1) 37F175HCS8Y 3/8-24 X 1 3/4 HEX CAP
- I) (2) 37NSAEFWZ WASHER, 3/8, FLAT, ZINC, GR-5
- J) (1) 37FNNEZ NUT, 3/8-24 NYLOCK
- K) (4) 31C125HCS8Y HEX CAP SCREW 5/16-18 X 1
- L) (4) 31CNWFZ 5/16-18 WHIZ FLANGE NUT

MASTER POWER BRAKES 888-533-1199