



# MASTER POWER BRAKES

110 Crosslake Park Road, Mooresville, NC 28117

Website: [www.mpbrakes.com](http://www.mpbrakes.com)

Technical Support: 888-533-1199

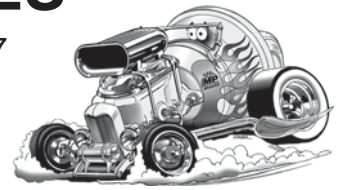

## WARNING

Proper operation of your brakes is essential for your safety and the safety of others. Any brake service should be performed **ONLY** by persons experienced in the installation and proper operation of brake systems. Proper installation is the responsibility of the person installing the component or kit for the particular application. After installation and before operating your vehicle, be sure to test the function of the brakes under controlled conditions.

→ **DO NOT DRIVE WITH UNTESTED BRAKES!** ←

FOR TECHNICAL ASSISTANCE CALL:

**888-533-1199**

MONDAY - FRIDAY

8:00 A.M. TO 5:00 P.M. E.S.T.

## CHECK ORDER IMMEDIATELY WARRANTY INFORMATION

Take time to read all the information that came with this kit. Check the provided list of parts against what you received to ensure all parts are present. While this kit was designed to make the process of changing brake parts as simple as possible, **with some applications it may be necessary to make minor changes to your vehicle.**

***Read all warranty disclaimers and return policies included in this kit prior to installation.***

You have: **5 days** to declare shipping damages  
**30 days** to declare missing or incorrect parts  
**90 days** for exchanges or returns (RA req'd)  
**1 year** before product warranty expires.

*No exceptions allowed.*

*Thank you for your business!*



MASTER POWER BRAKES

110 Crosslake Park Road, Mooresville, NC 28117

Website: [www.mpbrakes.com](http://www.mpbrakes.com) Technical Support: 888-533-1199

© 2006 MP Brakes. All rights reserved. Master Power® is a registered trademark of Master Power Brakes, LLC





# DB1786M/MHP

## 1953-1962 CORVETTE DISC BRAKE CONVERSION KIT

### INSTALLATION INSTRUCTIONS



# MASTER POWER BRAKES

110 CROSSLAKE PARK RD MOORESVILLE N.C. 28117

[www.mpbrakes.com](http://www.mpbrakes.com) 704-664-8866



REVISED 3\_2011

# INSTALLATION INSTRUCTIONS

## INCLUDED COMPONENTS

Your conversion kit should contain the following components:

1. Dual manual master with adaptor flange
2. Manual push rod
3. Combination valve kit
4. Caliper bracket kit with bearings, seals, dust caps, hardware and bearing adaptors.
5. Calipers with pads
6. Caliper hoses with hose bolts and crush washers
7. Rotors (OE Style shown - HP Kit includes cross-drilled/slotted rotors)

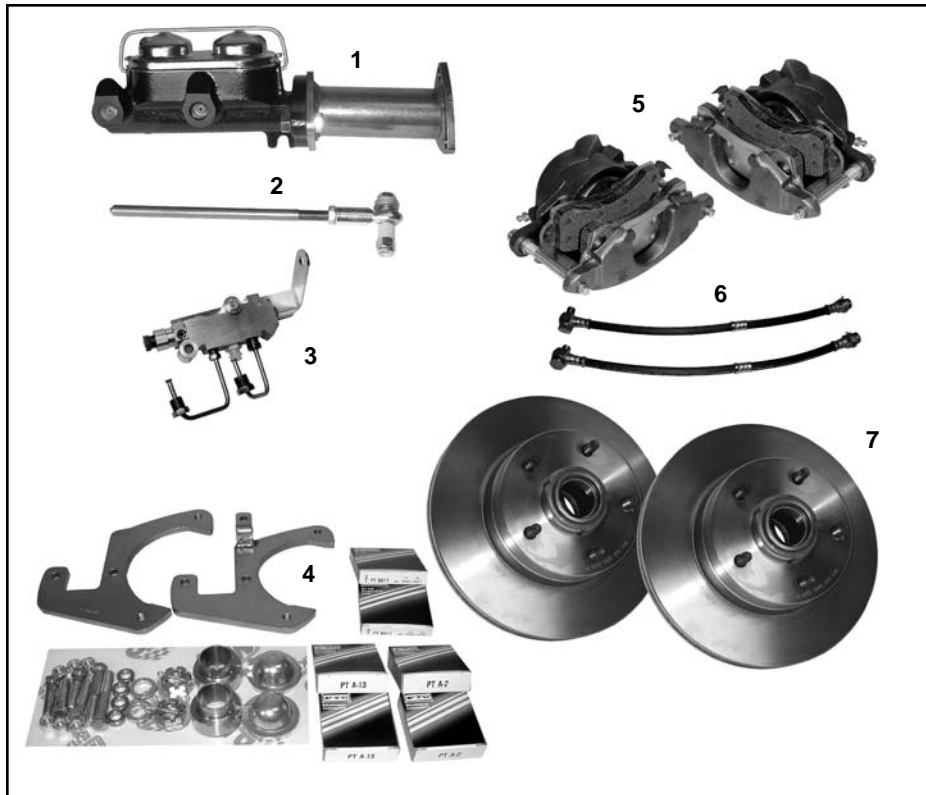

## INSTALLATION

1. Remove the original drum brakes and backing plates from the spindles. Retain the bearing nut and keyed washer for later use.
2. Thoroughly clean any grease and dirt from the spindle. Check spindle thoroughly for cracks or damage.
3. Using one of the original bolts in the forward hole re install the steering arm in it's stock location on the spindle. Using the hardware supplied in the kit install the caliper bracket to the spindle as shown. Insert the 1/4" spacers between the bracket and the spindle as shown. Trim the bracket as necessary. The brackets mount to the rear of the spindles.

Drivers side



Drivers side

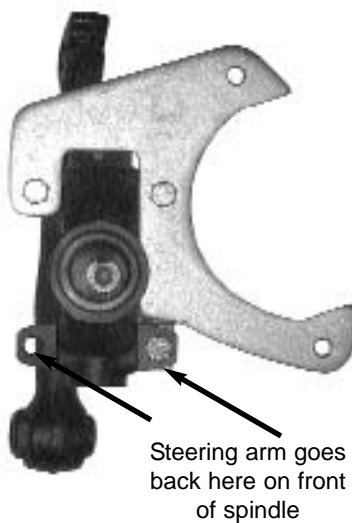

Drivers side

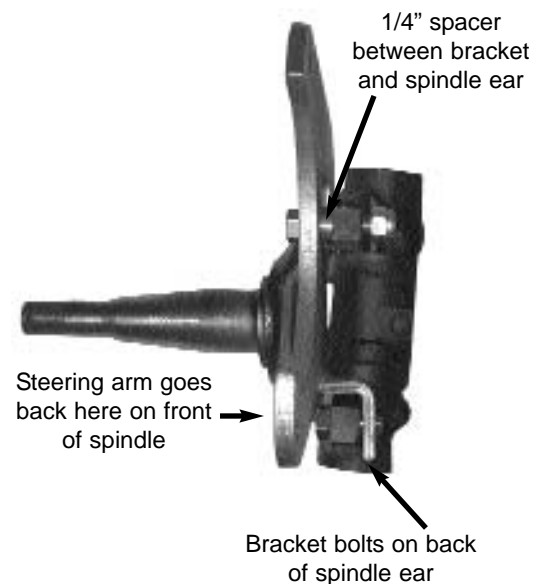

4. Examine the inner wheel bearing seating area for wear or damage. Emery cloth the seating area on the spindle for a smooth surface.
5. The supplied wheel bearing adapter is a press-fit. It can be installed one of three ways.
  - Method A:** Using an oven, heat adapter to at least 300 degrees Fahrenheit for at least 30 minutes. Slide adapter on spindle until seated and allow to cool.
  - Method B:** Slide adapter on spindle. Drive adaptor on spindle using suitable section of 1/2in pipe and hammer. If spindle is on car, insert block of wood between spindle and frame.
  - Method C:** Remove spindle from car. Using hydraulic press, press adaptor onto spindle.Note: Supplied bearing adapter has 1.280in I.D. and 1.375in O.D.

**BE SURE TO GREASE THE BEARINGS WITH A GOOD QUALITY BEARING GREASE BEFORE INSTALLING**



6. Remove the inner bearing race from the supplied rotor. Replace it with the supplied A-13 race and bearing. Install the supplied 8871 seal. Be sure to firmly seat the seal.
7. Install the rotor onto the spindle making sure the inner bearing seats all the way onto the bearing adapter.  
NOTE: The bearings and adapters are machined to .0005" tolerance. If the bearing does not slide onto the spindle adaptor easily it may be due to tolerance "stack up". This can be rectified by a small amount of emery cloth sanding on the bearing adapter surface.
8. Install the supplied A-2 outer bearing followed by the brass 3/4 x 1/4" thick spacer. Install the stock keyed retaining washer and retaining nut. Adjust bearings as required and install cotter key and bearing dust cover.
9. Inspect the caliper prior to installation. Install the caliper onto the bracket with the **bleeder facing up** using the supplied caliper mounting bolts.
10. Connect the caliper hoses to the caliper. Be sure the brass hose end is sandwiched between the supplied copper crush washers.

## DUAL MASTER CYLINDER INSTALLATION

**NOTE: Will not fit 53-54 Corvette with original engine or 57-62 with stock fuel injection.**

### INCLUDED COMPONENTS

Your dual master conversion kit will contain the following components:

1. Low profile master
2. Master cylinder adaptor
3. Adjustable push rod with pedal attachment

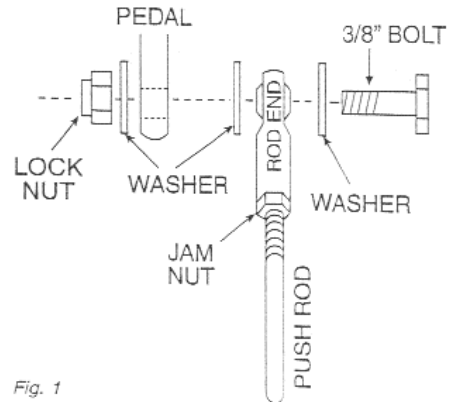
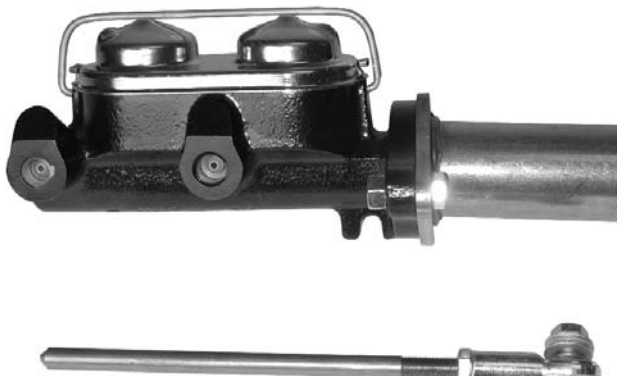

1. Remove the clevis pin on the original brake pedal push rod by removing the cotter pin and the clevis. Retain the clevis pin, return spring and return spring bracket.
2. Unscrew the hydraulic line from the master cylinder.
3. Unbolt the three attaching nuts from the master cylinder mounting using a 9/16 socket. Save the nuts.
4. Remove the master cylinder from the firewall.
5. Slide the new master cylinder adaptor onto the three bolts on the firewall and install the locknuts and washers. Tighten securely.
6. Mount the new master cylinder onto the adaptor with the included hardware.
7. From inside the car insert the master cylinder push rod with the rod end on the left side of the pedal. Make sure the supplied bushing is in place in the pedal. Install the 3/8" bolt and washer as in diagram.
8. Check the clearance of the push rod to the master cylinder piston. There should be 1/8" clearance. Adjust the rod to the correct length and tighten the jam nut.
9. Install the return spring.
10. Fill the master and bleed the system. Use only correct brake line and double flared ends.
11. Try the pedal before moving the car.