



MASTER POWER BRAKES

110 Crosslake Park Road, Mooresville, NC 28117

Website: www.mpbrakes.com

Technical Support: 888-533-1199

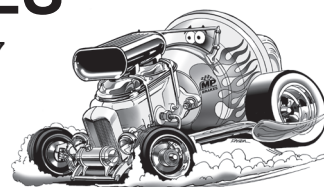

WARNING

Proper operation of your brakes is essential for your safety and the safety of others. Any brake service should be performed **ONLY** by persons experienced in the installation and proper operation of brake systems. It is the responsibility of the person installing the component or kit for the particular application. After installation and before operating your vehicle, be sure to test the function of the brakes under controlled conditions.

→ **DO NOT DRIVE WITH UNTESTED BRAKES!** ←

FOR TECHNICAL ASSISTANCE CALL:

888-533-1199

MONDAY - FRIDAY

8:00 A.M. TO 5:00 P.M. E.S.T.

CHECK ORDER IMMEDIATELY WARRANTY INFORMATION

Take time to read all the literature that came with this kit. Check the provided list of parts against what you received to ensure all parts are present. While this kit was designed to make the process of changing brake parts as simple as possible, **with some kits it may be necessary to make minor changes to your car.**

Read all warranty disclaimers and return policies included in this kit prior to installation.

You have: **5 days** to declare shipping damages
30 days to declare missing or incorrect parts
90 days for exchanges or returns (RA req'd)
1 year before product warranty expires.

No exceptions allowed.

Thank you for your business!



MASTER POWER BRAKES

110 Crosslake Park Road, Mooresville, NC 28117

Website: www.mpbrakes.com Technical Support: 888-533-1199

© 2006 MP Brakes. All rights reserved. Master Power® is a registered trademark of Master Power Brakes, LLC



DB1742 Series

Installation Instructions

WARNING:

Installation of any component or kit should only be performed by persons experienced in the installation and proper operation of disc brake systems. It is also the responsibility of the person installing any brake component or kit to determine the suitability of the component or kit for that particular application.

NOTE:

Before operating the vehicle after installation test the function of the brakes under controlled conditions. Make several stops in a safe area from low speed and gradually work up to normal speeds. **DO NOT DRIVE WITH UNTESTED BRAKES!**
Always utilize safety restraints when operating the vehicle.

STEP 1:

Be sure to check to be sure that your kit has all the necessary parts needed to complete this project! (Use the supplied parts list as a check list.)

STEP 2:

Remove the following components from you car:

Tech tip: Prior to disassembly spray the nuts and bolts that will be removed with a penetrant.

1. If you are performing the installation with a jack, be sure that the parking brake is set and that the rear wheels are chocked. Support the front of the vehicle with jack stands. Never work on sloping ground.
2. If you are using a lift, raise the vehicle to a comfortable working height.
3. Remove the front tires.
4. At this point, be sure to place the proper support under the lower control arm. Failure to do so will allow the coil spring to blow out when spindle is removed, which could result in vehicle damage and possible serious injury or even death.
5. Next, disconnect the drum brake hoses from the hard line using the appropriate flare wrenches.
6. Now remove the dust cap, cotter pin, spindle nut, spindle washer, bearings and drum from the drum brake spindle.
7. Remove the steering arm from the original drum brake assembly and set it aside for later use.
8. Now disconnect the ball joints from the spindle and remove the spindle.
9. Clean and inspect ball joints and tie rod ends for excessive wear or damage, replace at this time if necessary, in preparation for assembly.

STEP 3:

Things to prepare before assembly of the new disc brake kit:

1. Measure the two mounting holes in the steering arm, they should be 1/2", if not, drill out to 1/2".
2. Grease the bearings. (Use a high quality disc brake bearing grease.)

STEP 3: (cont.)

3. Install the greased inner bearing and the rotor seal onto the rotor. **Note: The supplied rotors come with races, so you can disregard the races that are with the bearings.**
4. Clean the rotors using brake cleaner first, then with soap and water. Dry with a clean towel.

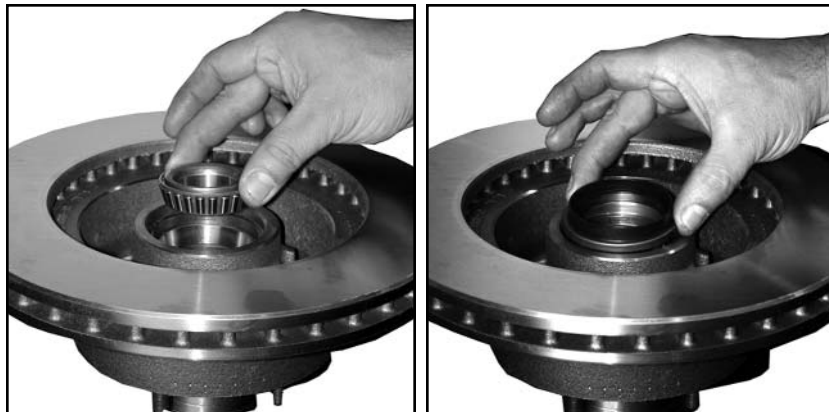

STEP 4:

Installation of disc brake components:

1. Start with a clean spindle.
2. Place the new disc brake spindle onto the lower ball joint. Torque the nut to the correct specifications for your vehicle. Insert the cotter pin and bend it.
3. Raise the control arm support and repeat process in number 1 for the upper ball joint. Remember to use the correct torque specifications.
4. Using the supplied 5/8" bolt, attach the caliper bracket and dust shield to the spindle. The dust shield will go on top of the caliper bracket. The caliper bracket should also be mounted so that the caliper will be located toward the rear of the car. **(As shown below)**
5. Now install the two 1/2" bolts and install the steering arm in the same direction that it was removed. The 2 3/4" long bolt goes through the thickest part of the steering arm. **(As shown below)**

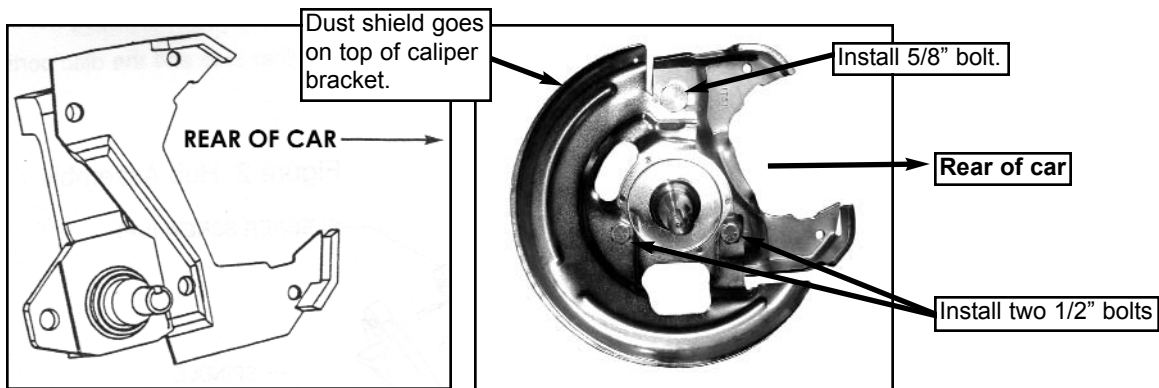
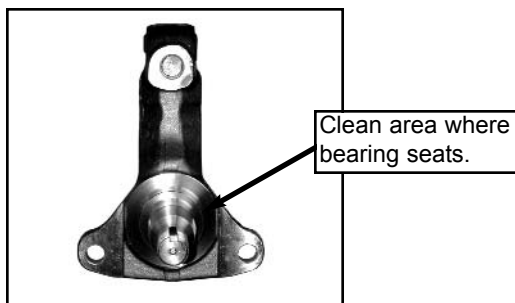

6. Now install the original steering arm to the new spindle in the same direction that it was removed and attach the tie rod end.

Picture shown is a rear steer application.

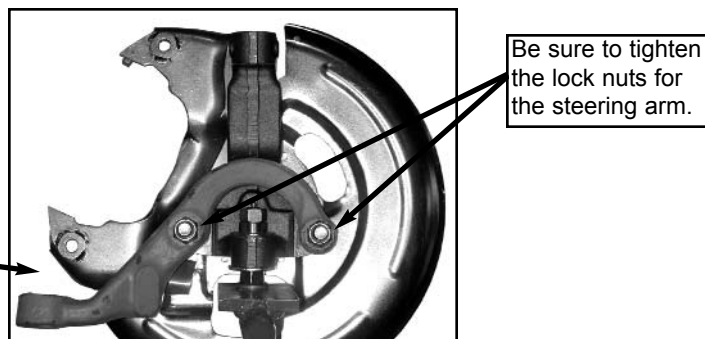

For Camaros, Firebirds and Novas, place the .322" thick spacer onto the stud with the thinner hole on the steering arm before installing the nut.

7. Install the rotor (with inner bearing and seal already installed) and then install the outer bearing, spindle washer, spindle nut, cotter pin and finally the dust cap. **Now, it might be a good idea to wipe the rotor again with brake cleaner to remove any oil or grease applied during installation.**



Install outer bearing.

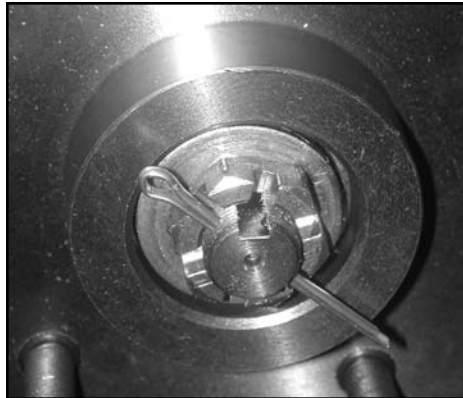

Install spindle washer, nut & cotter pin.



Install dust cap & clean rotor.

8. Install the caliper with pads in place onto the caliper bracket and tighten the caliper mounting bolts. **Be sure to mount the caliper to the rear of the car with the bleeder screw up!**

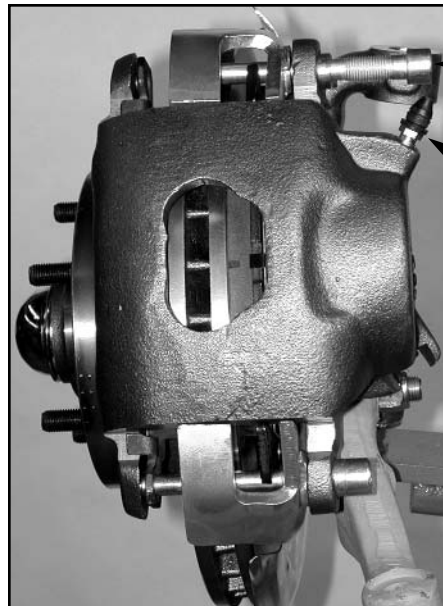

Insert caliper bolts

Bleeder screw should be pointing up!

9. Attach the brake hose with provided banjo bolt and copper washers. The hose will exit toward rear of the car. Then attach the hose to the hard line at the frame. **Now repeat this process for other side.**

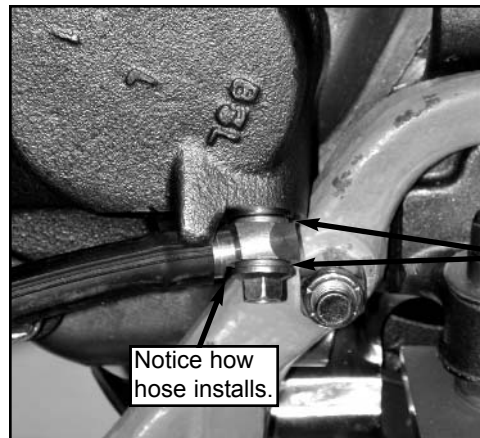
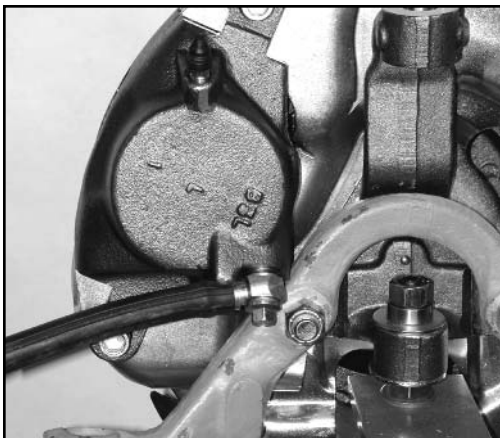

Notice how hose installs.

Be sure to use the two copper crush washers.

MANUAL MASTER INSTALLATION:

1. Disconnect the master cylinder push rod from the brake pedal.
2. Remove the old master cylinder.
3. Using the two holes which line up with the larger hole, install the new master.
4. Attach the master cylinder push rod to the pedal with the supplied clevis attachment.
5. Place the proportioning valve bracket onto one of the nuts that holds the master and tighten.
6. Mount the valve to the bracket.
7. Run the two supplied pre-bent lines from the master to the valve.
8. Run hard line from the valve to the front and rear part of the braking system as per the valve diagram.

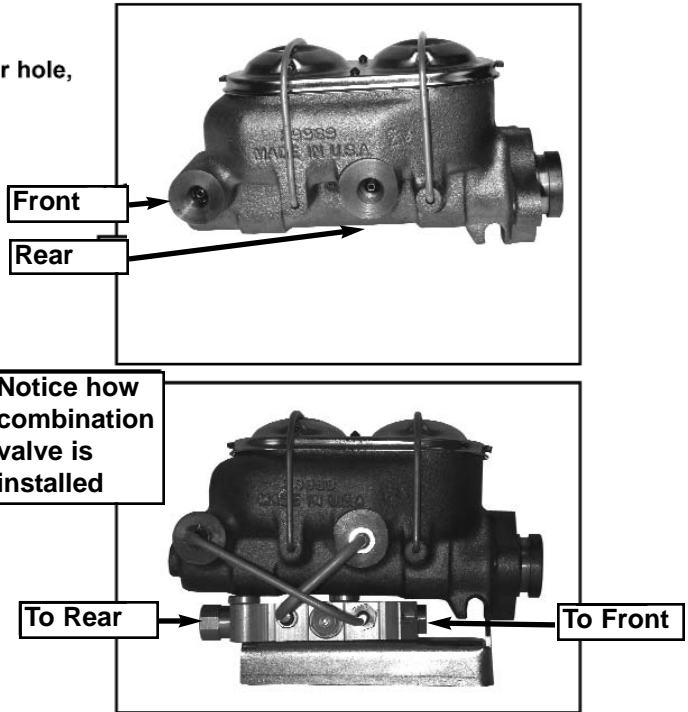

NOTE: When running lines to the front, you can plug one of the outlets on the valve (to front) and splice the one brake line to front calipers. You do not need to run two separate lines to the combination valve.

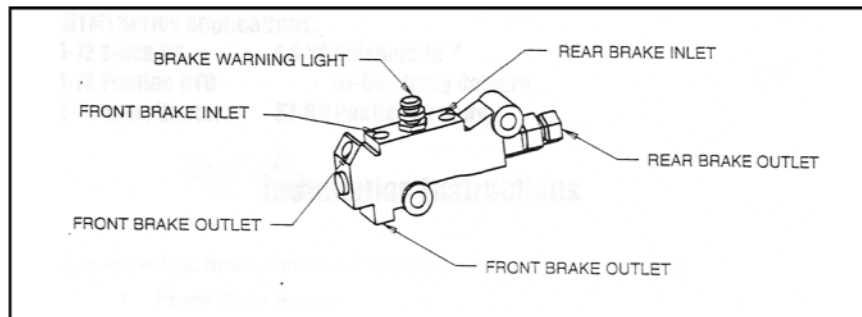

DB1742MHP
DISC KIT, 64-72 SLOTTED ROTOR GM A/F BODY
PARTS LIST

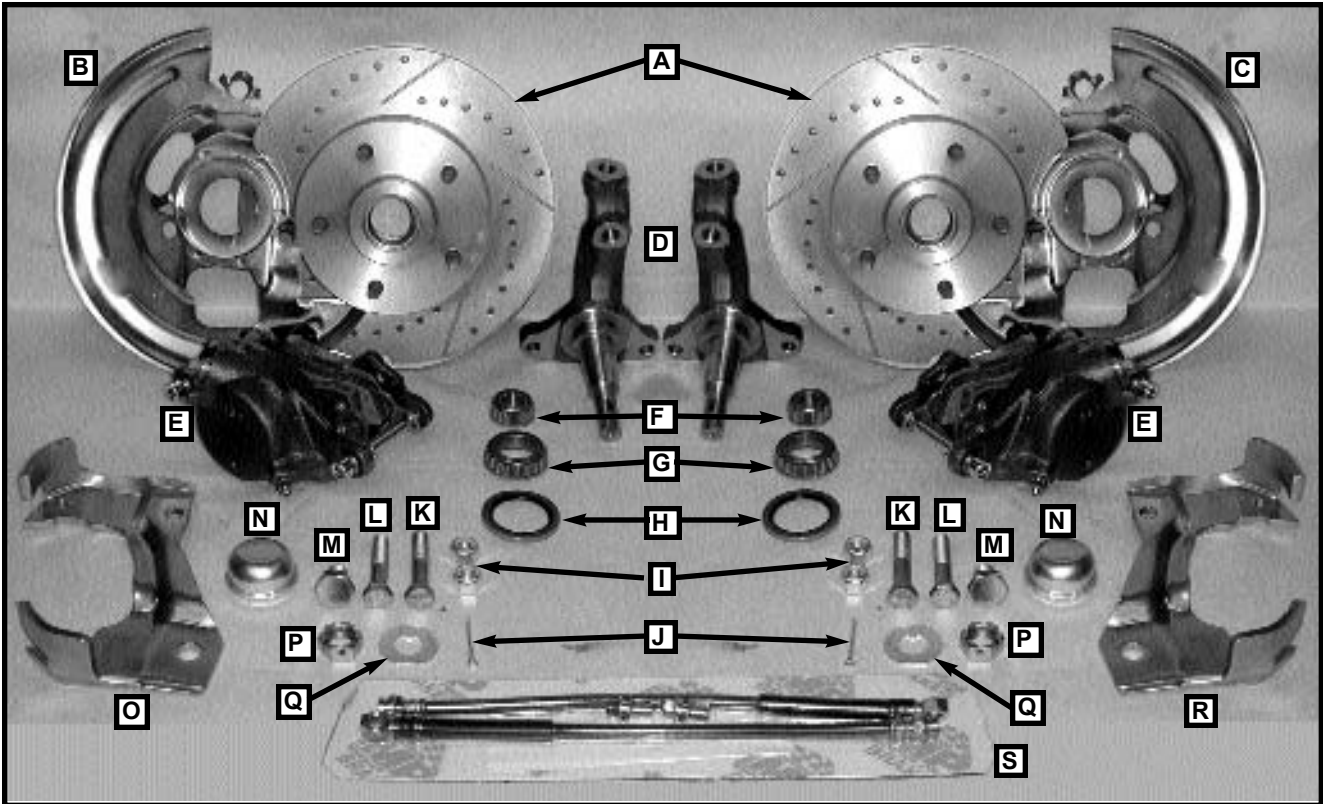

PARTS LIST

- A) (1) RT85532LHP ROTORS, SLOTTED, LEFT ****SOLD IN PAIRS****
 (1) RT85532RHP ROTORS, SLOTTED, RIGHT ****SOLD IN PAIRS****
- B) (1) AC1700D DUST SHIELD, GM, DRIVER-SIDE
- C) (1) AC1700P DUST SHIELD, GM, PASS.-SIDE
- D) (2) SP1731 SPINDLES, DISC BRAKE, CHEVY II ***NEW***
- E) (2) CA403940 CALIPERS, GM, LARGE, SINGLE PISTON
- F) (2) HWA2 BEARING, OUTER
- G) (2) HWA6 BEARING, INNER
- H) (2) HW8705 SEAL, ROTOR
- I) (4) 50FNNEZ NUT, 1/2-20, NYLOCK, ZINC
- J) (2) 12R150PCOZ PIN, COTTER, 1/8 X 1 1/2 ZINC
- K) (2) 50F275HCS8Y BOLT, 1/2-20 X 2 3/4 HCS GR-8 ZINC YELLOW
- L) (2) 50F250HCS8Y BOLT, 1/2-20 X 2 1/2 HCS ZINC YELLOW
- M) (2) HW1702 BOLTS, CALIPER BRACKET
- N) (2) HW4001 CAPS, DUST, 45.2MM /1 25/
- O) (1) BRCA1741L BRACKETS, CALIPER LEFT S 64-72 GM MID-SIZE
- P) (2) HW615065 NUT, SPINDLE, GM
- Q) (2) HW615005 WASHER, SPINDLE ORG. GM
- R) (1) BRCA1741R BRACKETS, CALIPER RIGHT S 64-72 GM MID-SIZE
- S) (1) HS88520K HOSE KIT, FRONT, 69-77, 16 GM, SINGLE PISTON CALIPER SET
 (2) HS88520 HOSE, F, 69-71 CAMARO 16
 (2) HW210-82 BOLT, HOSE 7/16 X 20 SHORT
 (4) HW4390 COPPER SEALING WASHER USED W/ 4039 & 4040 CALIPER
- T) (1) PD-0524 PADS, GM FULL SIZE, CARBON ←→ (NOT SHOWN)

DB1742MHP
CONTINUED

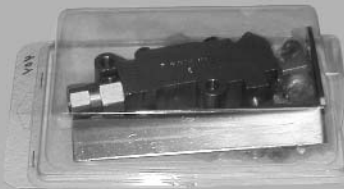

PARTS LIST (CONT.)

- U) (1) MC390360M MASTER CYLINDER, GM, 1" BORE, 7/16" STROKE
DUAL RESERVOIR
- V) (1) VL3360K VALVE KIT, W/ FITTINGS
 - (1) 25C175HCS5Z 1/4 X .175 BOLT
 - (1) 25CNNEZ 1/4 COURSE NYLOCK NUT
 - (1) BR1261N BRACKET, VALVE, UNIVERSAL
 - (2) HW105-3 NUT, 3/16 TUBE 3/8-24 THD
 - (1) HW106-3 PLUG, 3/16"
 - (2) HW106-4 PLUG, INVERTED STEEL 1/4" O.D.
 - (1) HW115-37 NUT, 3/16 TUBE 7/16-24 THD RED
 - (1) HW115-38 NUT, 3/16 TUBE 1/2-20 THD BLACK
 - (1) HW115-39 NUT, 3/16 TUBE 9/16-18 THD OLIVE
 - (1) HW1709 PLUG, SWITCH, COMBO VALVE
 - (1) HW210-43 ADAPTOR, BRASS 7/16-3/8M
 - (2) HW300-3 COUPLER 3/16
 - (2) HW300-4 COUPLER 1/4
 - (2) HW300-5 COUPLER 1/2
 - (1) HW3359 PLUG, COMBO VALVE, 4 WHEEL DISC
 - (1) HW702-3 T-FITTING 3/16 X 3/16 X 3/16
 - (1) VL3350 VALVE, COMBO, DISC / DRUM
- W) (1) AC2002 BLEEDER KIT, USED IN DUAL MASTER CYLINDER APPLICATION

MASTER POWER BRAKES 888-533-1199