



# MASTER POWER BRAKES

110 Crosslake Park Road, Mooresville, NC 28117

Website: [www.mpbrakes.com](http://www.mpbrakes.com)

Technical Support: 888-533-1199

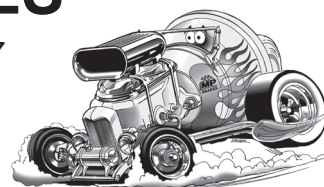

## WARNING

Proper operation of your brakes is essential for your safety and the safety of others. Any brake service should be performed **ONLY** by persons experienced in the installation and proper operation of brake systems. It is the responsibility of the person installing the component or kit for the particular application. After installation and before operating your vehicle, be sure to test the function of the brakes under controlled conditions.

→ **DO NOT DRIVE WITH UNTESTED BRAKES!** ←

FOR TECHNICAL ASSISTANCE CALL:

**888-533-1199**

MONDAY - FRIDAY

8:00 A.M. TO 5:00 P.M. E.S.T.

## CHECK ORDER IMMEDIATELY WARRANTY INFORMATION

Take time to read all the literature that came with this kit. Check the provided list of parts against what you received to ensure all parts are present. While this kit was designed to make the process of changing brake parts as simple as possible, **with some kits it may be necessary to make minor changes to your car.**

***Read all warranty disclaimers and return policies included in this kit prior to installation.***

You have: **5 days** to declare shipping damages  
**30 days** to declare missing or incorrect parts  
**90 days** for exchanges or returns (RA req'd)  
**1 year** before product warranty expires.

*No exceptions allowed.*

*Thank you for your business!*



MASTER POWER BRAKES

110 Crosslake Park Road, Mooresville, NC 28117

Website: [www.mpbrakes.com](http://www.mpbrakes.com) Technical Support: 888-533-1199

© 2006 MP Brakes. All rights reserved. Master Power® is a registered trademark of Master Power Brakes, LLC



# DB1724M INSTALLATION INSTRUCTIONS

## INCLUDED COMPONENTS

Your disc brake conversion kit will contain the following components:

1. Rotors
2. Caliper mounting brackets and hardware
3. Calipers with pads
4. Bearings, seals, and dust caps
5. Caliper hoses



## INSTALLATION

### STEP #1

Remove the stock Chevy front drums, brakes and backing plates. Clean and inspect the spindles for cracks or damage. Be sure to thoroughly clean out the 11/16" threaded hole at the top of the spindle. This is extremely important. Use a non oil based cleaner such as Brake Clean. Clean the threads out with a bottoming tap if necessary.



## STEP #2

Now install the small support bracket (BR1723). You will need to loosen the bolts that hold on the steering arm and replace them with the bolts that are supplied in the kit. (See Figure "A")

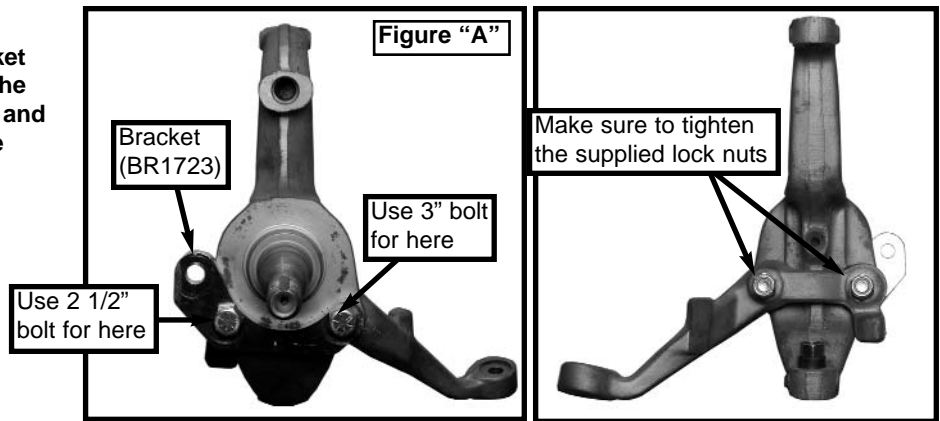

## STEP #3

Now attach the the caliper bracket (BRCA1723) to the spindle using the supplied shoulder bolt. Make sure not to tighten to much, just finger tighten the bolt. (See Figure "B")

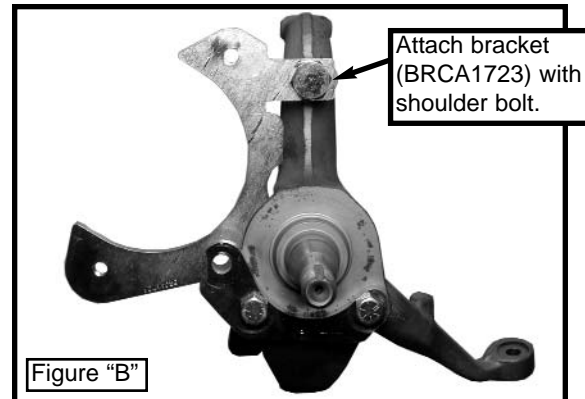

## STEP #4

Install the bushing between the small support bracket (BR1723) and the caliper bracket (BRCA1723). Use the 2" bolt that is supplied and tighten with lock nut. (Now you can tighten the shoulder bolt at the top of the spindle.) (See Figure "C")

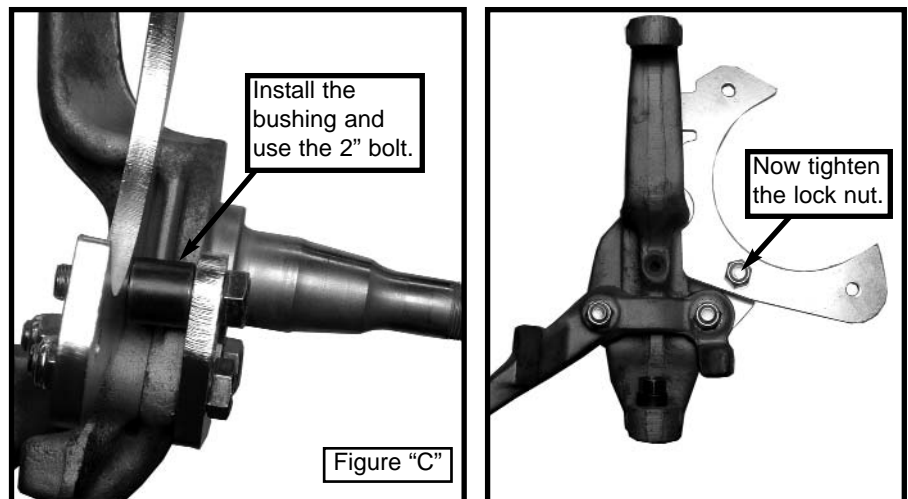

## STEP #5

You will need to remove the bearing race from the front of the rotor and replace with the one supplied in bearing pack (HWA34). (See Figure "D")



### STEP #6

(Grease the inner and outer wheel bearings with a high quality wheel bearing grease.) Install the inner wheel bearing into the hub followed by the grease seal. You will not need to replace the bearing race in the back of rotor. Be sure to tap the seal flush with the hub surface. (See Figure "E")

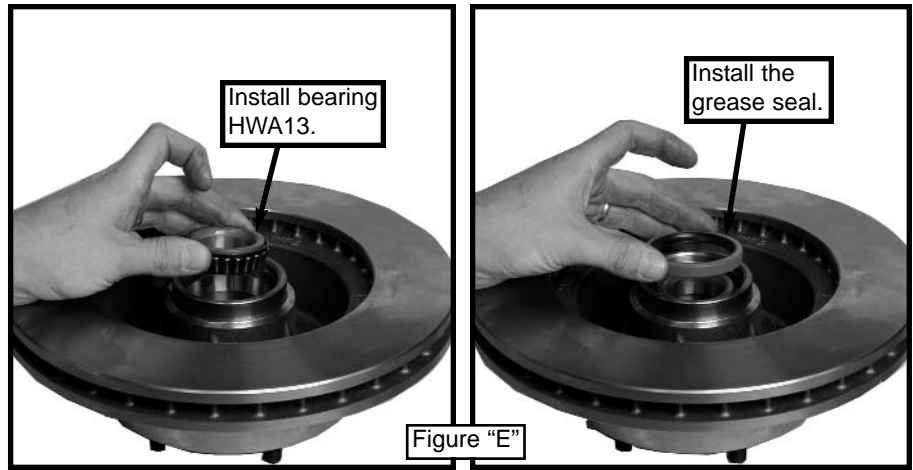

### STEP #7

Slide the rotor onto the spindle followed by the outer bearing. Then slide on the spindle washer. (See Figure "F")

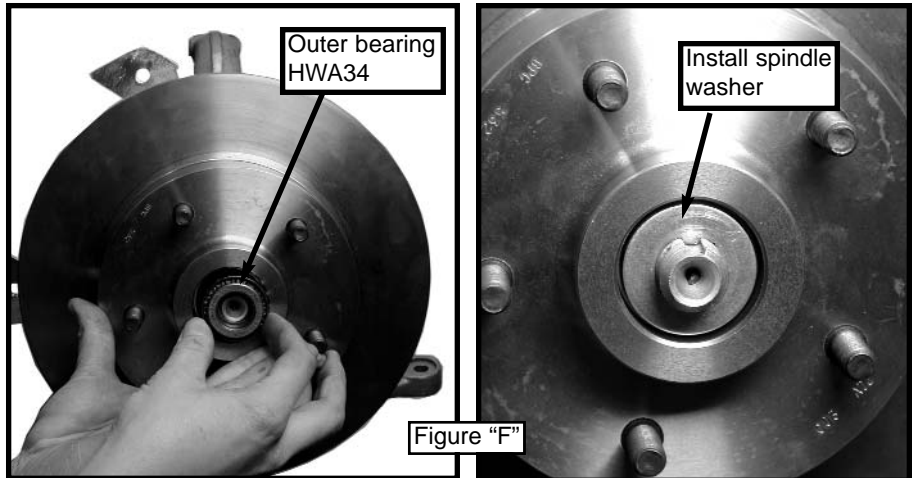

### STEP #8

Now install the spindle nut and tighten until the rotor moves freely but is not loose. (For this kit you will need to install the spindle nut backwards) Now use the cotter pin to secure the spindle nut from coming loose. Then put on the dust cap. (See Figure "G")

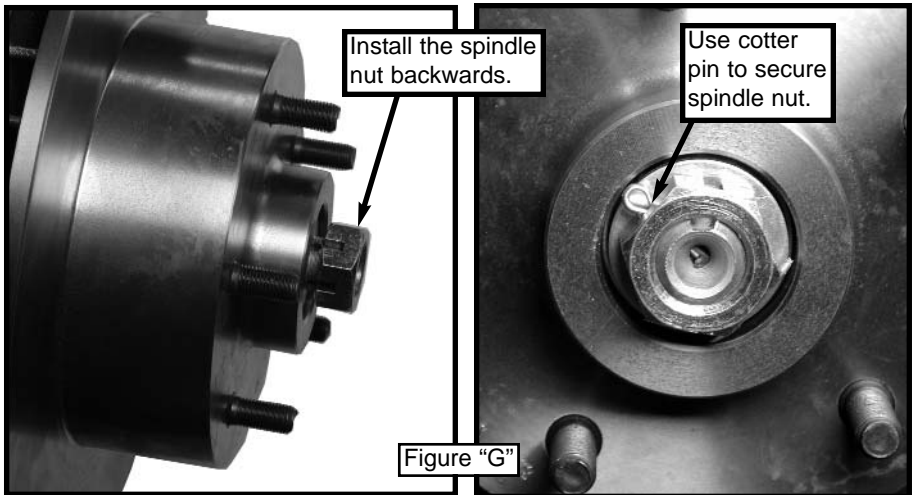

## STEP #9

Now attach the caliper with pads to the caliper bracket and tighten the caliper bolts securely. Make sure that the bleeder screw is facing up. (Now check for wheel clearance on the caliper before you turn the wheel. Turn the wheel slowly to be sure there are no points of interference between the caliper and the wheel.) Then install the brake hoses with the supplied hose bolts and washers. (Check for clearance at full left and right turns. Do not check with the wheels on the ground.)

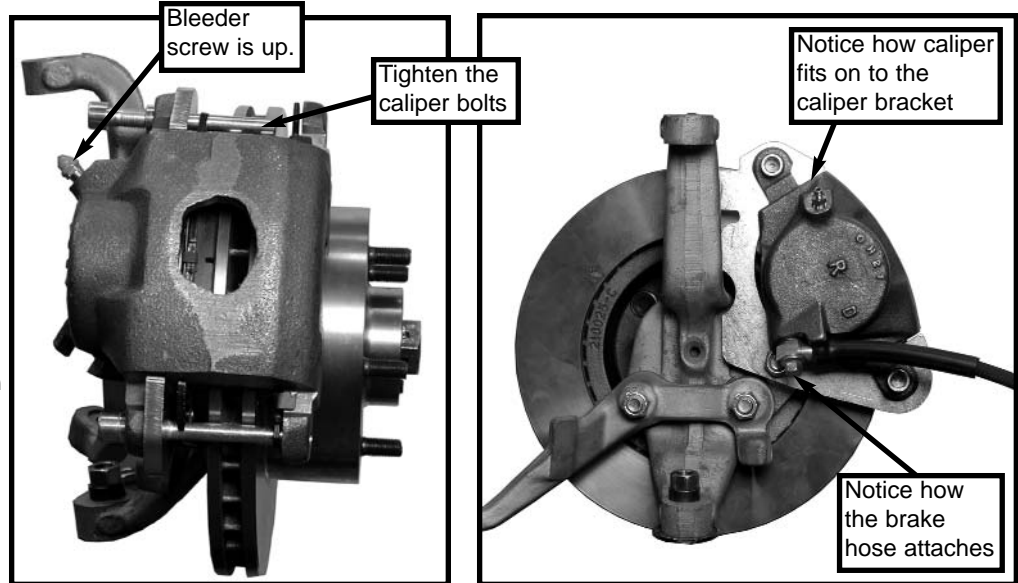

**Bleed the entire system using new DOT3 or DOT4 fluid.  
Check the brake pedal for firmness before moving.**

## MASTER POWER BRAKES

For more info or help you can go to our web-site at:  
[911brakes.com](http://911brakes.com)  
or call tech support at:  
1-888-251-2353  
or  
[www.mpbrakes.com](http://www.mpbrakes.com)

**MANUAL MASTER INSTALLATION:**

1. Disconnect the master cylinder push rod from the brake pedal.
2. Remove the old master cylinder.
3. Using the two holes which line up with the larger hole, install the new master.
4. Attach the master cylinder push rod to the pedal with the supplied clevis attachment.
5. Place the proportioning valve bracket onto one of the nuts that holds the master and tighten.
6. Mount the valve to the bracket.
7. Run the two supplied pre-bent lines from the master to the valve.
8. Run hard line from the valve to the front and rear part of the braking system as per the valve diagram.

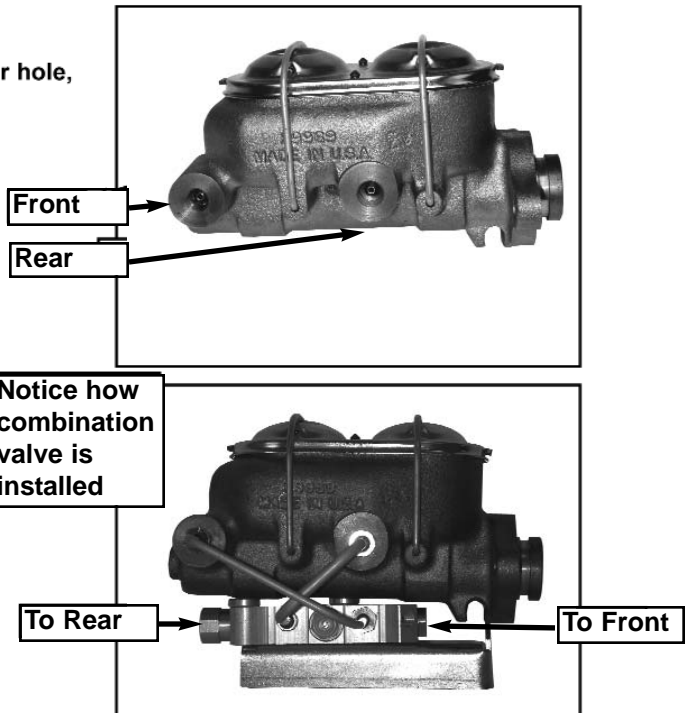

**NOTE:** When running lines to the front, you can plug one of the outlets on the valve (to front) and splice the one brake line to front calipers. You do not need to run two separate lines to the combination valve.

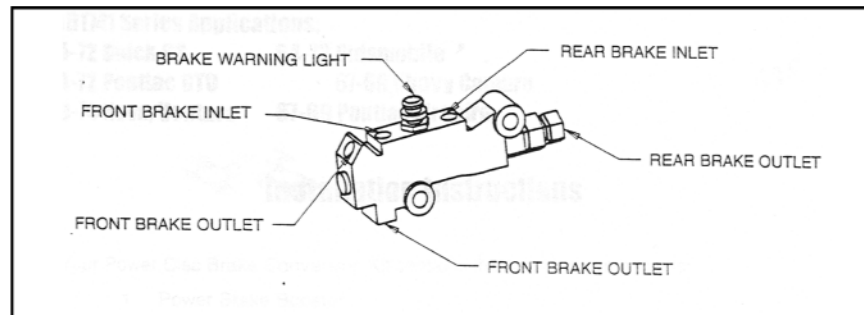

**DB1724M**  
**DISC KIT, 69-70 F/S CHEVY, MANUAL KIT**  
**\*\*\*USES CUSTOMERS SPINDLES\*\*\***  
**PARTS LIST**

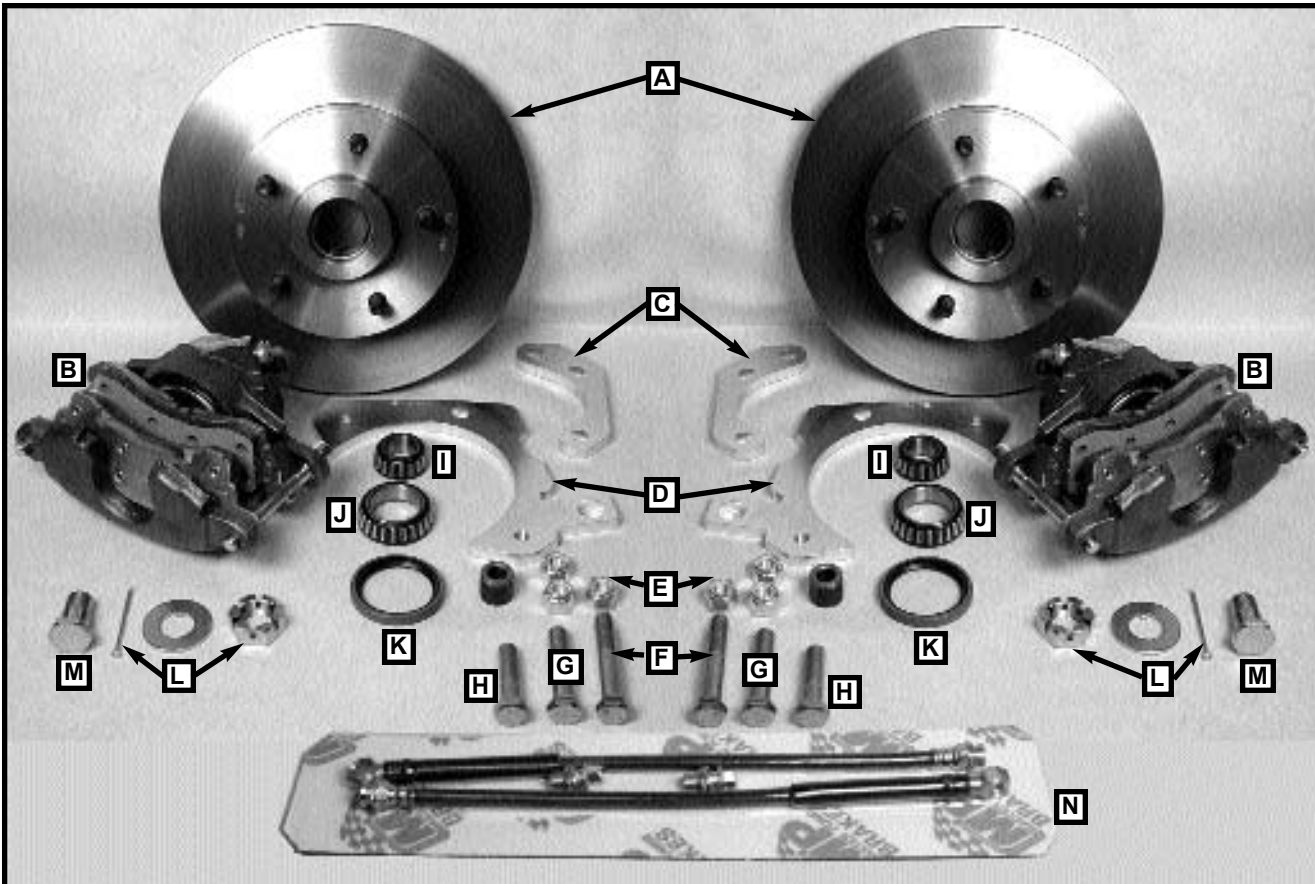

**PARTS LIST**

- A) (2) RT141039 ROTOR, SINGLE PISTON CALIPER  
69-72 CHEVELLE, 67-69 CAMARO,  
69-74 MONTE CARLO
- B) (2) CA403940 CALIPERS, GM, LARGE, SINGLE PISTON
- C) (2) BR1723 BRACKET, SECONDARY SUPPORT TO BRCA1723
- D) (2) BRCA1723 BRACKETS, CALIPER 69-70 FULL SIZE
- E) (6) 50FNNEZ NUT, 1/2-20, NYLOCK ZINC
- F) (2) 50F300HCS8Y BOLT, 1/2-20 X 3 HCS GR-8 ZINC YELLOW
- G) (2) 50F250HCS8Y BOLT, 1/2-20 X 2 1/2 HCS GR-8 ZINC YELLOW
- H) (2) 50F200HCS8Y BOLT, 1/2-20 X 2 HCS GR-8 ZINC YELLOW
- I) (2) HWA34 BEARING, OUTER
- J) (2) HWA13 BEARING, INNER
- K) (2) HWCR19215 SEAL, ROTOR, GM/ MUSTANG II CONVERSIONS
- L (2) HW05110K SPINDLE NUTS X2, SPINDLE WASHERS X2, COTTER PINS X2
- M) (2) HW1116 SHOULDER BOLT, 11/16 X 1
- N) (2) HS88520K HOSE KIT, FRONT, 69-77, 16" GM SINGLE PISTON CALIPER SET
  - (2) HS88520 HOSE, F, 69-71 CAMARO
  - (2) HW21082 BOLT, HOSE 7/16 X 20 SHORT
  - (2) HW4390 COPPER SEALING WASHER USED W/ 4039 & 4040 CALIPER

DB1724M  
CONTINUED



**PARTS LIST (CONT.)**

- O) (1) MC390360M MASTER CYLINDER, GM, 1" BORE, 7/16" STROKE  
DUAL RESERVOIR
- P) (1) VL3360K VALVE KIT, W/ FITTINGS
  - (1) 25C175HCS5Z 1/4 X .175 BOLT
  - (1) 25CNNEZ 1/4 COURSE NYLOCK NUT
  - (1) BR1261N BRACKET, VALVE, UNIVERSAL
  - (2) HW105-3 NUT, 3/16 TUBE 3/8-24 THD
  - (1) HW106-3 PLUG, 3/16"
  - (2) HW106-4 PLUG, INVERTED STEEL 1/4" O.D.
  - (1) HW115-37 NUT, 3/16 TUBE 7/16-24 THD RED
  - (1) HW115-38 NUT, 3/16 TUBE 1/2-20 THD BLACK
  - (1) HW115-39 NUT, 3/16 TUBE 9/16-18 THD OLIVE
  - (1) HW1709 PLUG, SWITCH, COMBO VALVE
  - (1) HW210-43 ADAPTOR, BRASS 7/16-3/8M
  - (2) HW300-3 COUPLER 3/16
  - (2) HW300-4 COUPLER 1/4
  - (2) HW300-5 COUPLER 1/2
  - (1) HW3359 PLUG, COMBO VALVE, 4 WHEEL DISC
  - (1) HW702-3 T-FITTING 3/16 X 3/16 X 3/16
  - (1) VL3350 VALVE, COMBO, DISC / DRUM

**MASTER POWER BRAKES 888-533-1199**