



## WARNING

Proper operation of your brakes is essential for your safety and the safety of others. Any brake service should be performed ONLY by persons experienced in the installation and proper operation of brake systems. It is the responsibility of the person installing any brake component or kit to determine the suitability of the component or kit for the particular application. After installation and before operating your vehicle, be sure to test the function of the brakes under controlled conditions.

**DO NOT DRIVE WITH UNTESTED BRAKES!**

**FOR TECHNICAL ASSISTANCE CALL:**

**888-533-1199**

**MONDAY - FRIDAY**

**8:00 AM TO 5:00 PM EST**

## IMPORTANT

Take time to read all the literature that came with this kit. Check the provided list of parts against what you received to ensure all parts are present. While this kit was designed to make the process of changing brake parts as simple as possible. **NOTE: WITH SOME KITS IT MAY BE NECESSARY TO MAKE MINOR CHANGES TO YOUR CAR!**

**READ ALL WARRANTY DISCLAIMERS AND RETURN POLICIES INCLUDED IN THIS KIT PRIOR TO INSTALLATION!**

**MASTER POWER BRAKES**

**110 CROSSLAKE PARK RD. MOORESVILLE, N.C. 28117**

**[www.mpbrakes.com](http://www.mpbrakes.com)**



# DB1722 SERIES 1965-1968 CHEVROLET

## INSTALLATION INSTRUCTIONS

FOR TECHNICAL HELP  
CALL OUR TECH-LINE #  
888-533-1199



### **INCLUDED COMPONENTS**

Your disc brake conversion kit will contain the following components:

1. Rotors
2. Calipers with pads
3. Caliper hoses
4. Bearings and rotor seals
5. Bracket kit with hardware

**Note: Always refer to the vehicle owners manual for the correct torque specifications when installing this kit.**

## Step #1

Remove the stock Chevy front drums, brakes and backing plates. Clean and inspect the spindles for cracks or damage. Be sure to thoroughly clean out the 11/16" threaded hole at the top of the spindle. This step is extremely important. Use a non oil based cleaner such as brake cleaner. Clean the threads out with a bottoming tap if necessary.

Clean out the 11/16" threaded hole.

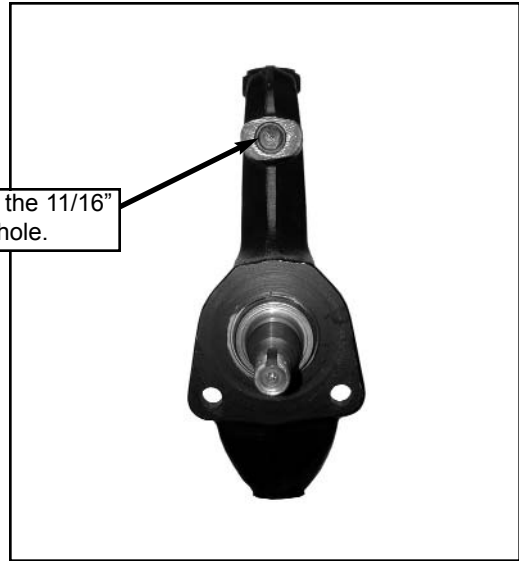

## Step #2

Take the small support bracket and install it on the outer surface of the spindle in the two lower holes. Install one of the long (1/2 x 3) bolts through the support bracket, through the rear hole on the spindle and through the steering arm. Install the shorter (1/2 x 2 1/2) bolt in a similar manner through the front hole. Install the supplied lock nuts and tighten.



Use the 1/2 x 3" bolt.

Use the 1/2 x 2 1/2" bolt.

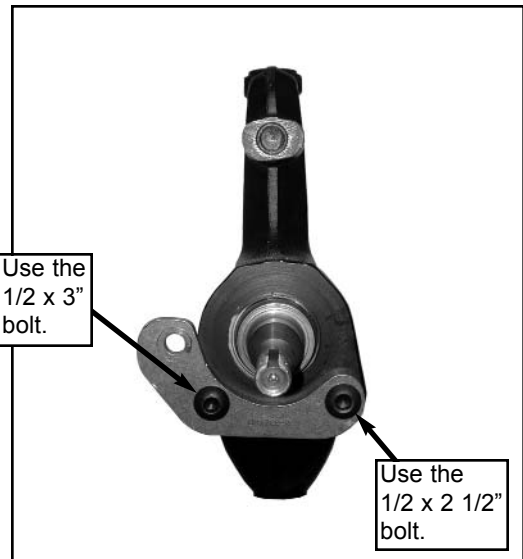

## Step #3

Take the larger caliper bracket and install it as follows: Install the (1/2 x 2 1/2) bolt through the small support bracket, spacer and caliper bracket. Install a lock nut and just snug it.

Just snug the lock nut!

Install the 1/2 x 2 1/2" bolt with bushing between the small support bracket and the caliper bracket.

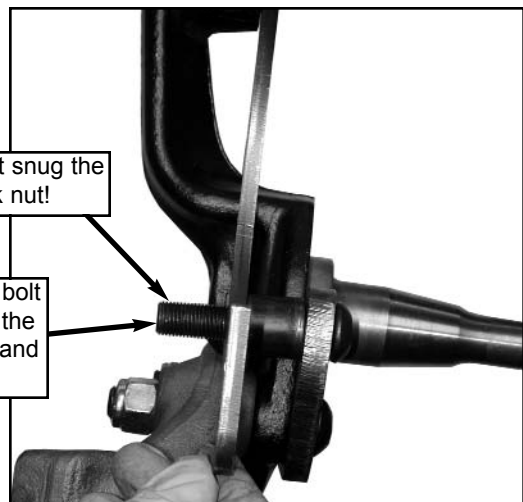

## Step #4

Install the 11/16" shoulder bolt through the caliper bracket into the spindle. Now tighten all the bolts and nuts.

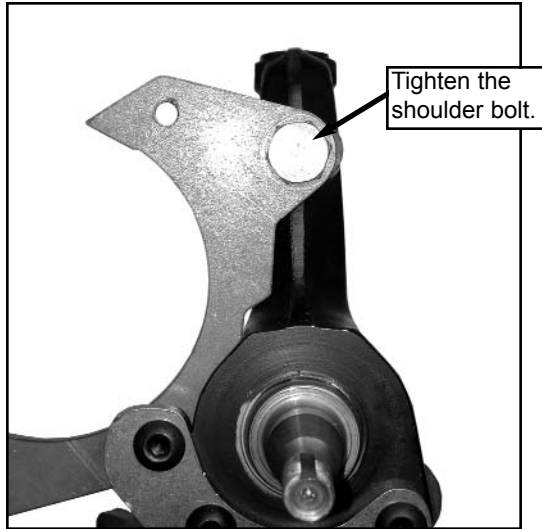

## Step #5

Take the new rotor and inspect for any problems / damage. Install the supplied inner A6 bearing. **BE SURE TO GREASE THE BEARINGS WITH A HIGH QUALITY BEARING GREASE BEFORE INSTALLATION!** Next, install the bearing seal into the rotor. (HW7934) Be sure to tap the bearing seal flush into the rotor before installing onto the spindle.



Install the inner A6 bearing.



Install the bearing seal (HW7934).

## Step #6

Install the rotor onto the spindle followed by the outer A2 bearing. Put the keyed bearing retaining washer followed by the spindle nut onto the spindle. Tighten the nut until there is a resistance to the rotor spinning freely and then loosen the nut slightly until the rotor spins freely. Turn the rotor on the spindle and check for any interference or minimal clearance between the inside surface of the rotor and the outer mounting bracket. Trim the bracket if necessary. Check for adequate clearance on the 1/2" bolts also. Be sure to install the cotter pin onto the spindle nut to secure.

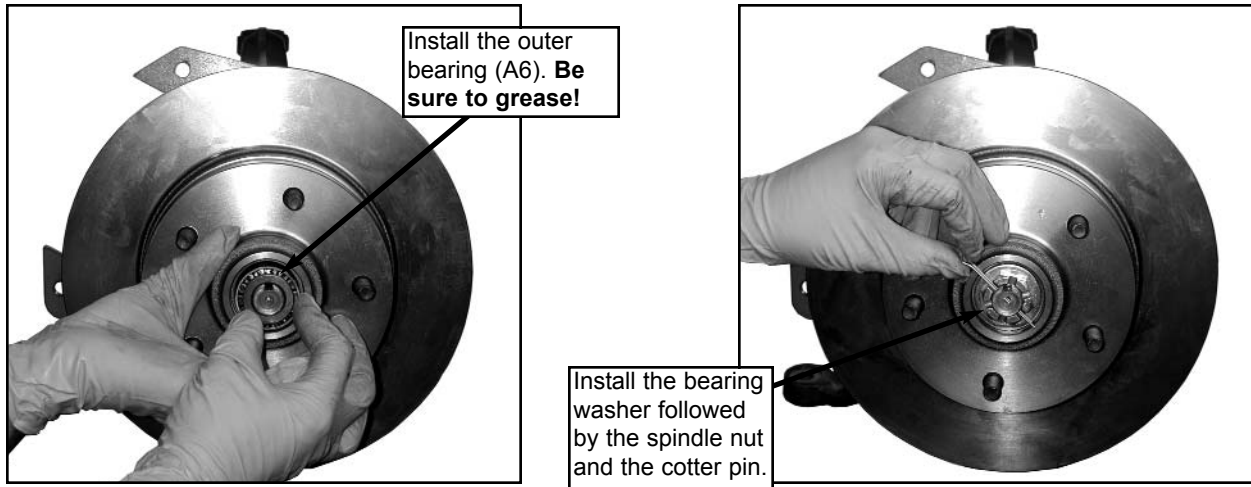

## Step #7

Install the loaded caliper onto the spindle using the supplied caliper mounting bolts. **THE CALIPER BLEEDER SCREW MUST FACE UP!** Now repeat the procedure for the opposite side.

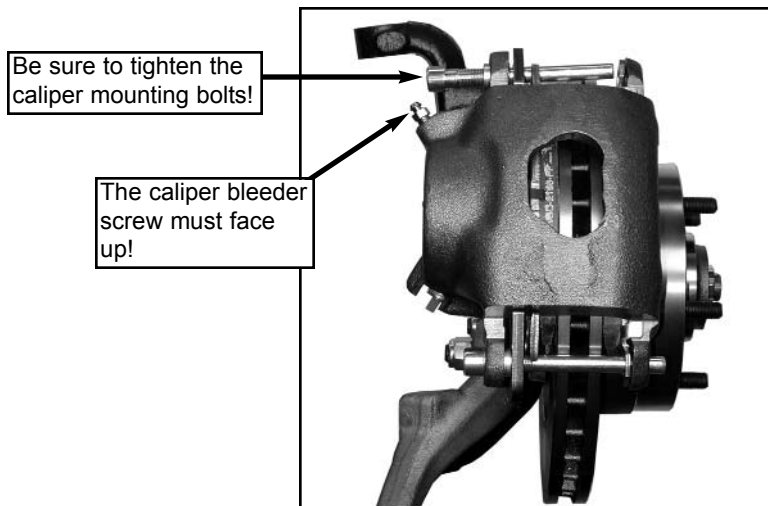

## Step #8

Then connect the supplied caliper hoses to the calipers and then to the hard line. Make sure that the brass mounting block of the caliper hose is sandwiched between two copper crush washers.

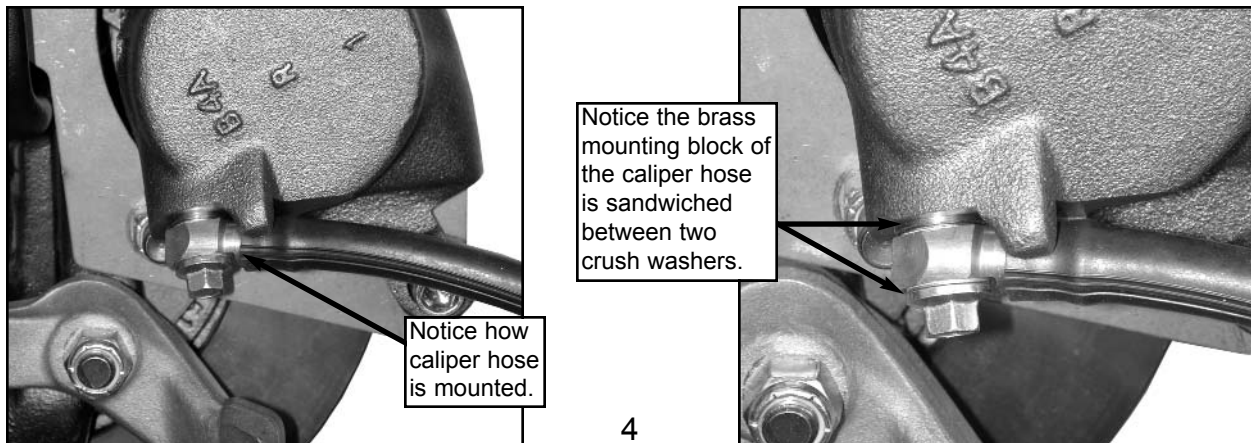

**MANUAL MASTER INSTALLATION:**

1. Disconnect the master cylinder push rod from the brake pedal.
2. Remove the old master cylinder.
3. Using the two holes which line up with the larger hole, install the new master.
4. Attach the master cylinder push rod to the pedal with the supplied clevis attachment.
5. Place the proportioning valve bracket onto one of the nuts that holds the master and tighten.
6. Mount the valve to the bracket.
7. Run the two supplied pre-bent lines from the master to the valve.
8. Run hard line from the valve to the front and rear part of the braking system as per the valve diagram.

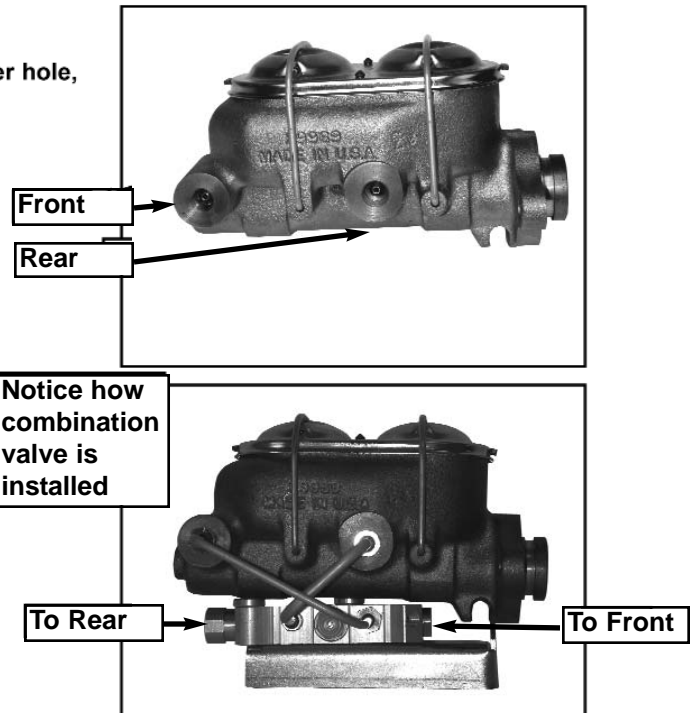

**NOTE:** When running lines to the front, you can plug one of the outlets on the valve (to front) and splice the one brake line to front calipers. You do not need to run two separate lines to the combination valve.

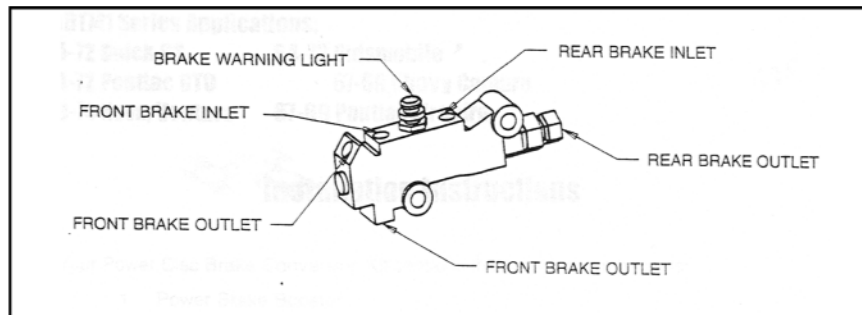

# DB1722MHP

## DISC KIT, 65-68 CHEVY SLOTTED/ X-DRILLED

### PARTS LIST

MASTER POWER BRAKES 888-533-1199

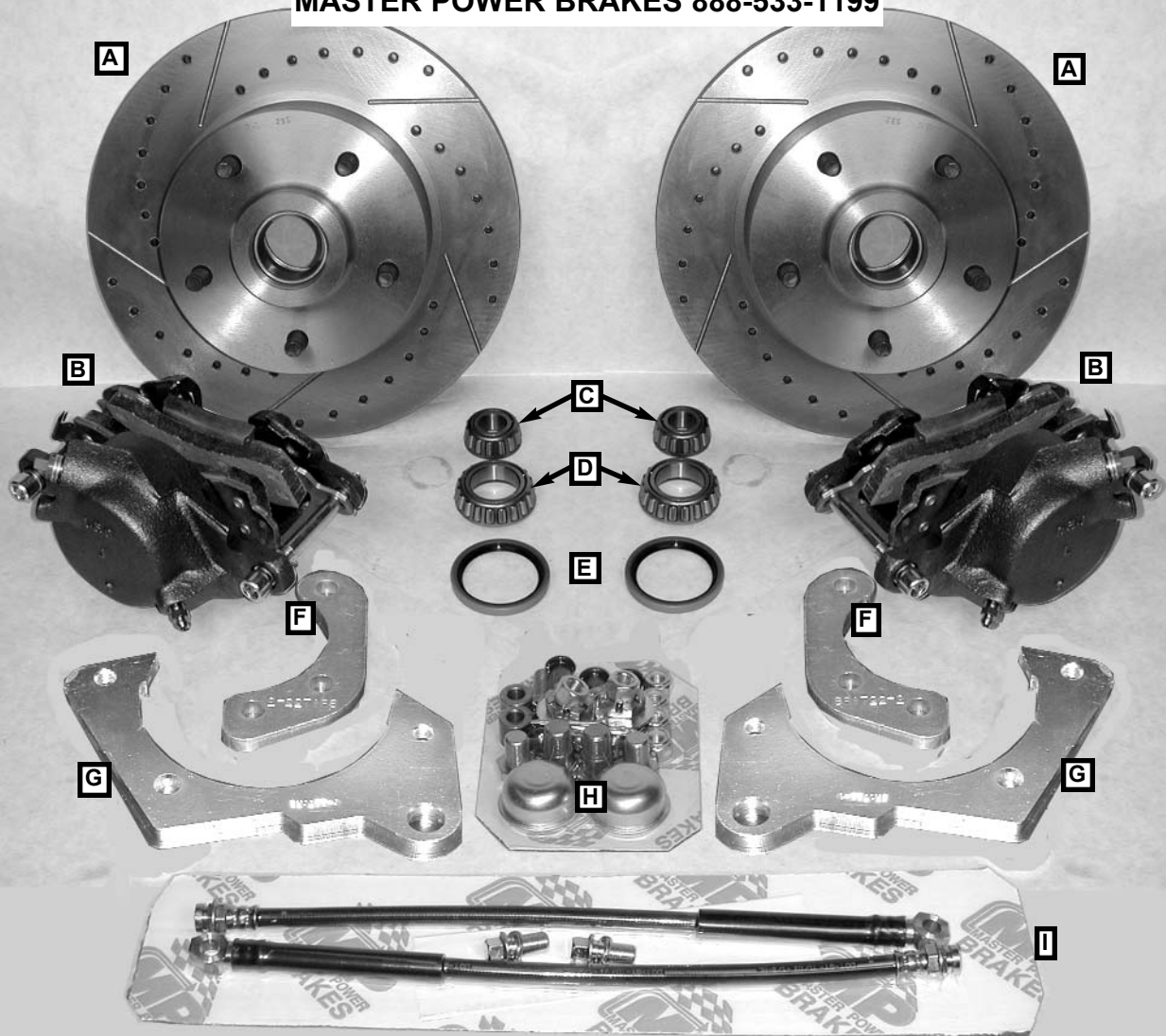

**PARTS LIST**

- A) (1) RT85532RHP ROTOR, SLOTTED, RIGHT \*\*\*\*\*SOLD IN PAIRS\*\*\*\*\*  
 (1) RT85532LHP ROTOR, SLOTTED, LEFT \*\*\*\*\*SOLD IN PAIRS\*\*\*\*\*
- B) (2) CA403940 CALIPERS, GM, LARGE, SINGLE PISTON
- C) (2) HWA2 BEARING, OUTER
- D) (2) HWA6 BEARING, INNER
- E) (2) HW7934 SEAL, ROTOR
- F) (2) BR1722-1 LARGE BRACKET, CALIPER, 65CHEVY
- G) (2) BRCA1722-2 SMALL BRACKET, CALIPER, 65 CHEVY
- H) (1) HW1722HK HARDWARE KIT  
 (2) 12R100PCOZ PIN, COTTER, 1/8 X 1 ZINC  
 (2) 15R150PCOZ PIN, COTTER, 5/32 X 1 1/2 ZINC  
 (4) 50F250KBC BOLT, 1/2-20 X 2 1/2 BUT SOC CAP SCREW  
 (2) 50F300KBC BOLT, 1/2-20 X 3 BUTTON CAP SCREW  
 (6) 50FNNEZ NUT, 1/2-20, NYLOCK ZINC  
 (2) BU1711 SPACER, CALIPER BKTS  
 (2) HW1116 SHOULDER BOLT, 11/16 X 1  
 (2) HW1702 BOLTS, CALIPER BRACKET  
 (2) HW4001 CAPS, DUST, 45.2MM /1 25/  
 (2) HW615005 WASHER, SPINDLE ORG. GM  
 (2) HW615065M SPINDLE NUT, GM, MODIFIED, MACHINED
- I) (1) HS88520K HOSE KIT, FRONT, 69-77, 16" GM, SINGLE PISTON CALIPER  
 (2) HS88520 HOSE, F, 69-71 CAMARO  
 (2) HW21082 BOLT, HOSE 7/16 X 20 SHORT  
 (4) HW4390 COPPER SEALING WASHER USED W/ 4039 & 4040 CALIPER

Revised 3/30/04

DB1722MHP  
CONTINUED



**PARTS LIST (CONT.)**

- J) (1) MC390360M MASTER CYLINDER, GM 1" BORE, 7/16" STROKE  
DUAL RESERVOIR
- K) (1) VL3360K VALVE KIT, W/ FITTINGS
- (1) 25C175HCS5Z 1/4 X .175 BOLT
  - (1) 25CNNEZ 1/4 COURSE NYLOCK NUT
  - (1) BR1261N BRACKET, VALVE, UNIVERSAL
  - (2) HW105-3 NUT, 3/16 TUBE 3/8-24 THD
  - (1) HW106-3 PLUG, 3/16"
  - (2) HW106-4 PLUG, INVERTED STEEL 1/4" O.D.
  - (1) HW115-37 NUT, 3/16 TUBE 7/16-24 THD RED
  - (1) HW115-38 NUT, 3/16 TUBE 1/2-20 THD BLACK
  - (1) HW115-39 NUT, 3/16 TUBE 9/16-18 THD OLIVE
  - (1) HW1709 PLUG, SWITCH, COMBO VALVE
  - (1) HW210-43 ADAPTOR, BRASS 7/16-3/8M
  - (2) HW300-3 COUPLER 3/16
  - (2) HW300-4 COUPLER 1/4
  - (2) HW300-5 COUPLER 1/2
  - (1) HW3359 PLUG, COMBO VALVE, 4 WHEEL DISC
  - (1) HW702-3 T-FITTING 3/16 X 3/16 X 3/16
  - (1) VL3350 VALVE, COMBO, DISC / DRUM

**MASTER POWER BRAKES 888-533-1199**

Revised 9/20/04