



WARNING

Proper operation of your brakes is essential for your safety and the safety of others. Any brake service should be performed ONLY by persons experienced in the installation and proper operation of brake systems. It is the responsibility of the person installing any brake component or kit to determine the suitability of the component or kit for the particular application. After installation and before operating your vehicle, be sure to test the function of the brakes under controlled conditions.

DO NOT DRIVE WITH UNTESTED BRAKES!

**FOR TECHNICAL ASSISTANCE CALL:
888-533-1199
MONDAY - FRIDAY
8:00 AM TO 5:00 PM EST**

IMPORTANT

Take time to read all the literature that came with this kit. Check the provided list of parts against what you received to ensure all parts are present. While this kit was designed to make the process of changing brake parts as simple as possible. **NOTE: WITH SOME KITS IT MAY BE NECESSARY TO MAKE MINOR CHANGES TO YOUR CAR!**

**READ ALL WARRANTY DISCLAIMERS AND RETURN POLICIES
INCLUDED IN THIS KIT PRIOR TO INSTALLATION!**

MASTER POWER BRAKES

110 CROSSLAKE PARK RD. MOORESVILLE, N.C. 28117

www.mpbrakes.com

DB1716BR REAR DISC KIT INSTALLATION INSTRUCTIONS

INCLUDED COMPONENTS:

Your power brake conversion kit will contain the following components:

1. Rear calipers, right & left
2. Rotors
3. Rear hoses & hose bolts
4. Caliper bracket kit
5. Pads
6. Mounting hardware
7. Parking brake cables
8. Spacer plates

NOTE: Use of this kit may require axle flange machining. Trial fit before machining. The axle flange must be 6 1/8"

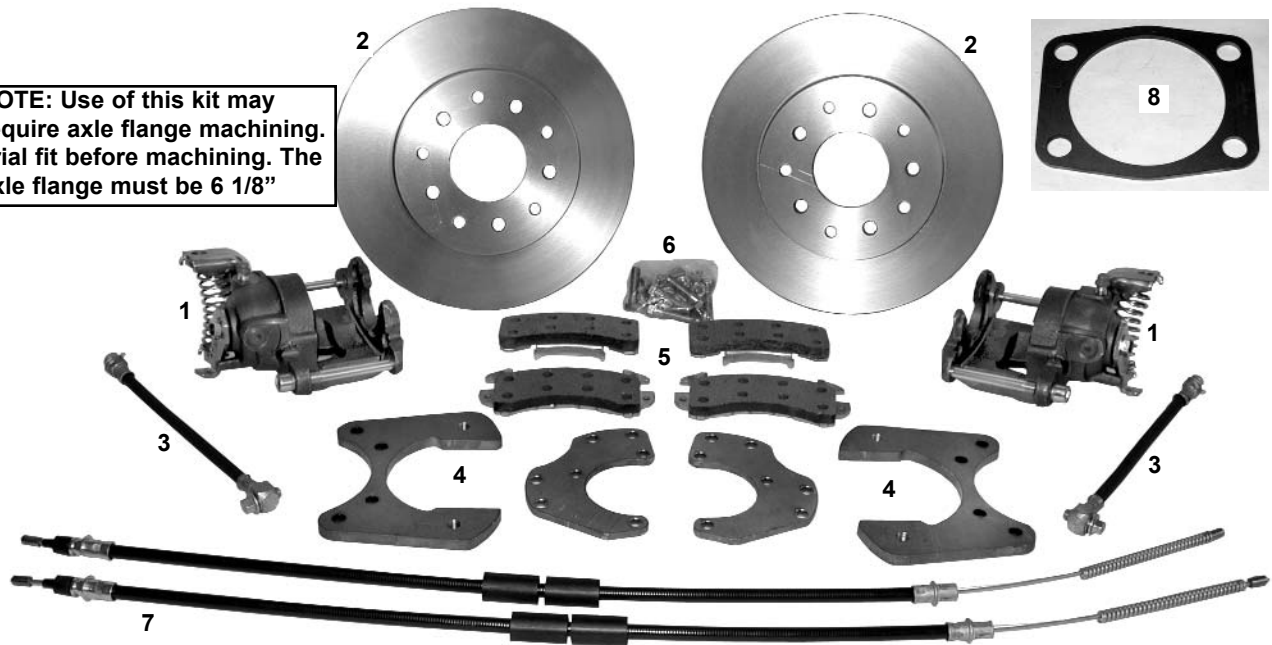

INSTALLATION:

Please read these instructions completely and trial fit the brackets, rotors and calipers to the axle housing before painting or plating any components. **(Modified components may not be returned for credit or exchange.)**

1. Remove the stock drums, brakes and backing plates from the axle housing. Clean the housing end flanges thoroughly. Install spacer plate to replace the backing plate. Remove axle flange retaining bolts - install axle into housing.



Remove stock drums, brakes, backing plates & clean!



Install spacer plate to replace the backing plate.



Remove axle flange retaining bolts - install axle into housing. **Axle flange may need to be machined.**

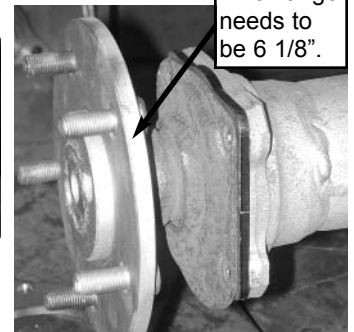

Axle flange needs to be 6 1/8".

2. Mount the primary support bracket to the inside of the axle housing flange with the secondary support bracket holes positioned for rear caliper mounting. Use 3/8-16 x 1 1/2" Allan socket head bolts to secure axle and primary bracket. Also use the supplied Hi-collar washer between flange and the bracket.

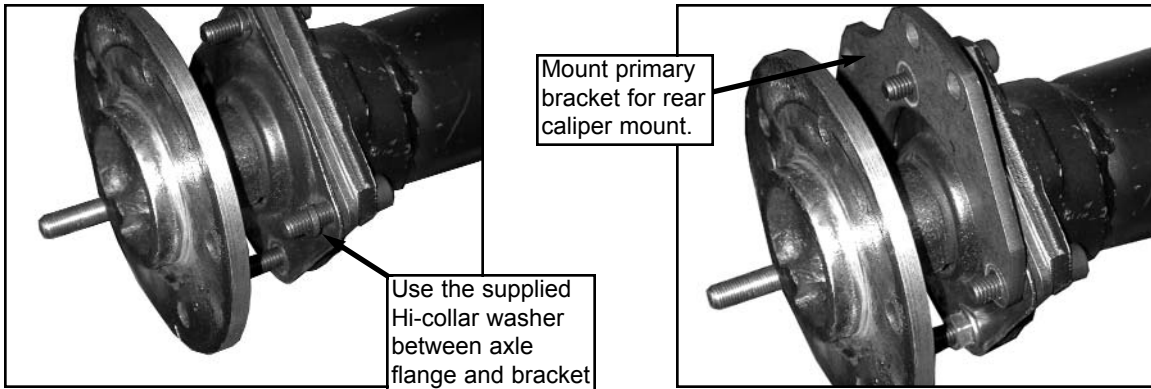

3. Attach the secondary bracket to the inside of the primary bracket with the spacers provided between the brackets as shown in the diagram using 3/8-24 x 2 1/4" bolts.

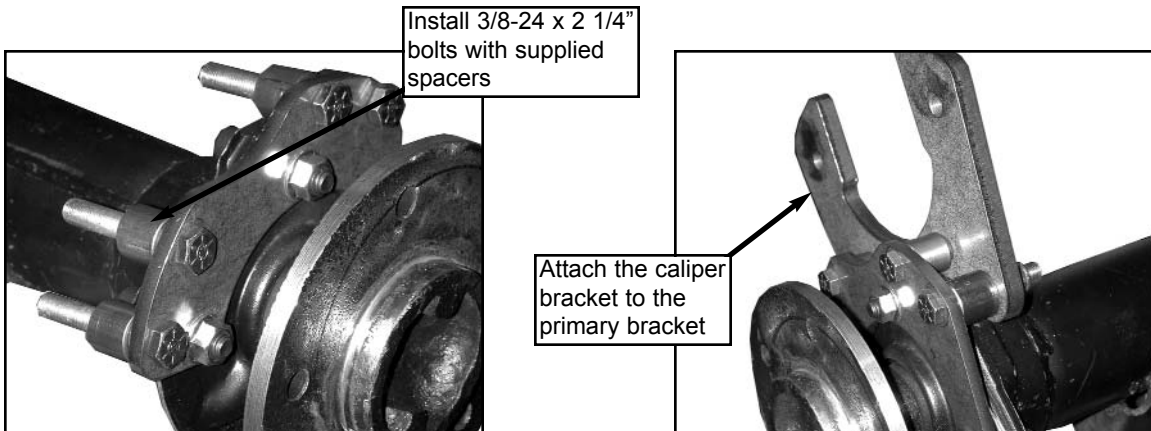

4. Mount the caliper assembly to the secondary bracket with the **bleeder screw and parking brake cable bracket pointing up.**
5. Check for adequate frame or suspension clearance. Check at full suspension travel up and down.
6. Attach hose (**not hard line, calipers float**). The hose bolt is GM 10mm. Fill the system and bleed. We recommend DOT4 or 5.1. *******Warranty is void if silicone fluid is used.*******
7. **IMPORTANT:** You must hook up the parking brake mechanism and use it on a regular basis. Failure to do so will result in the eventual loss of the rear brakes. Make sure the parking brake will hold against light throttle pressure.

NOTE: E-brake cable connection is the responsibility of the customer!

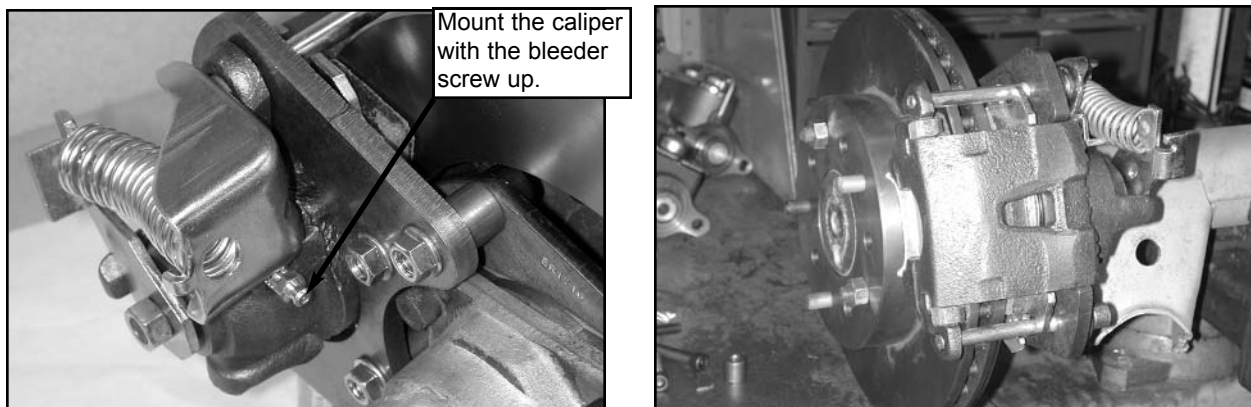

**There are some very important things you need to know about this setup.
It utilizes Trans Am rear rotors and Eldorado Cadillac rear calipers.**

One of the biggest advantages of a disc type brake is that it has a fool proof self adjuster. Not so with the rear disc GM! The rear calipers adjust off of the parking brake. The parking brake is incorporated into the caliper. You **MUST** set the parking brake every time you park your car! Not many people do that nowadays because it is much easier to just put the transmission in park and walk away! The rear caliper pistons utilize a "one way clutch" or "sprag" inside the caliper piston. When the parking brake is applied the sprag senses when there is .030 or more clearance between the friction material on the inboard side. When the distance is at least .030, the sprag turns inside the piston adjusting it out and keeping the rear brakes adjusted. If you are not setting your parking brake with this setup **EVERY** time you park your car then two things will happen. #1 - You will start to lose service brake pedal. #2 - The sprag will seize on the inside of the piston and will never work again. **NEVER** buy these calipers from a rebuilder, because rebuilders use the old piston in most cases and the piston is the reason the calipers were changed to begin with! Master Power Brakes uses only **NEW** calipers for this application! Also, when replacing rear pads on these calipers, GM says to "get into the vehicle after you have installed the pads and apply the parking brake 60 times". The short cut around this is to adjust the brakes out by unhooking the parking brake cable at the lever and adjusting the pistons out using the parking brake lever and a .030 feeler gauge between the inboard pad and the rotor. Then get in the vehicle and pump the parking brake 2-3 times.

This is a high quality kit at a bargain basement price! (If you go to Cadillac and buy these calipers new, they will cost you more than this whole kit.) But it is important that the new owner/builder is aware of the operation of these calipers.

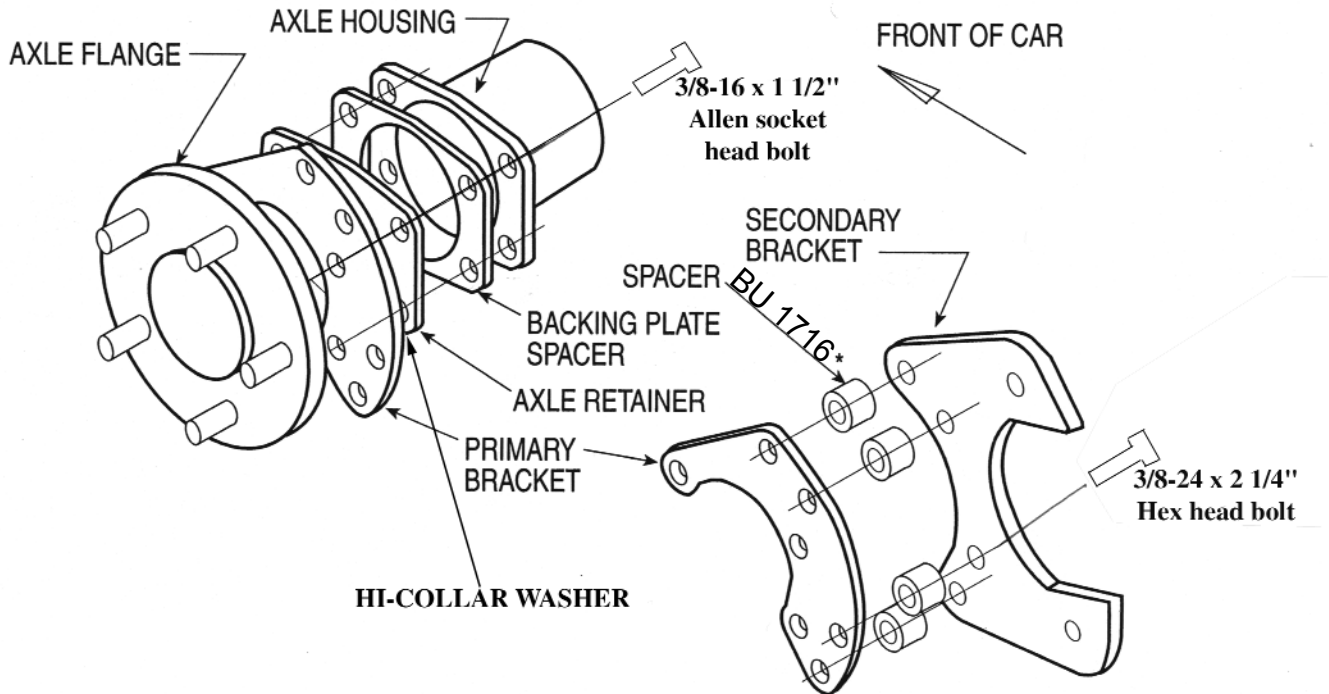

**MASTER POWER BRAKES
TECH-LINE#
888-533-1199**

WARNING

FOR YOUR REAR BRAKES TO OPERATE YOU MUST ADJUST THE REAR CALIPERS

When installing rear disc brakes with calipers that have an internal parking brake you must adjust or set the calipers when installing. Failure to do so will prevent you from getting a firm pedal and you will have no rear brake function. You must also set the parking brake every time you park to keep the calipers adjusted.

The caliper piston is adjusted outward by turning the nut on the lever or by cranking the lever. This ratchets the caliper piston outward moving the pads closer to the rotor. If you do not do this the rear calipers will take up brake fluid but the pads will never squeeze the rotor sending the pedal to the floor.

Only perform this adjustment with the caliper and rotor installed on the car. Start by spinning the rotor. Crank the lever and spin the rotor again to see if there is any drag. Continue cranking the lever until there is a slight drag on the rotor. Attach the parking brake cable. The caliper should now be adjusted. Repeat on the other side.

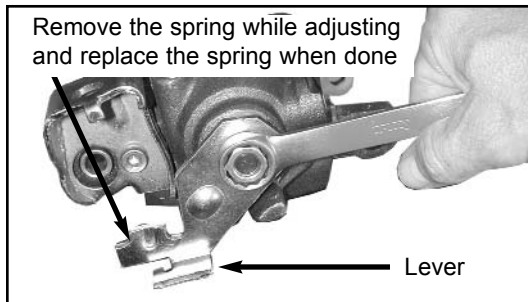

Remove the spring and crank the lever or turn the nut to adjust the piston outward.

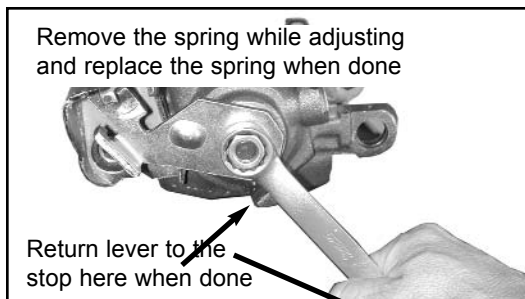

After cranking as far as lever will go rotate it back the other way until you hit the stop and reinstall the spring. The piston will remain out where it was.

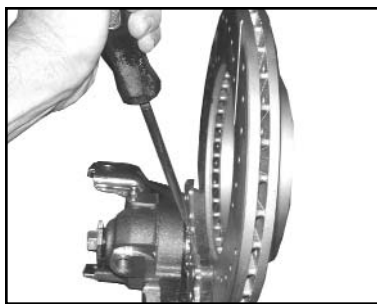

Helpful hint

To return the lever to the proper rest position use a large screwdriver against the outer lip on the caliper piston to force the piston against the pads firmly. When pressed firmly move the lever against the stop on the caliper casting. Replace the spring and attach cable.

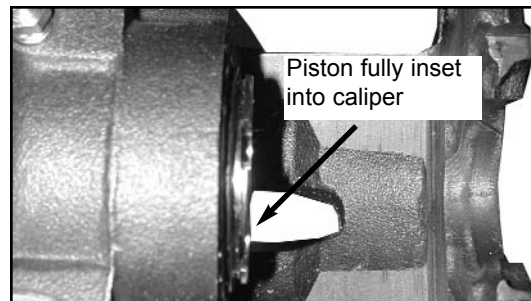

The picture above shows the caliper without any adjustment and the piston fully into the caliper.

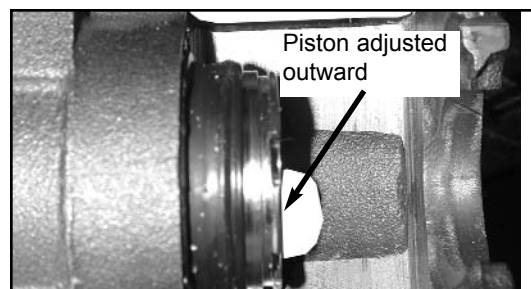

The caliper piston is able to be ratcheted out quite a distance. This will be required as the pads wear. Setting the parking brake when parking will continue to adjust the piston outward and keep the rear calipers functioning.

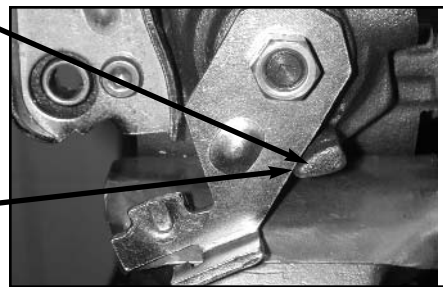

DB1716BR
55-72 REAR KIT, GM (FULL SIZE) 4 3/4 BC
PARTS LIST

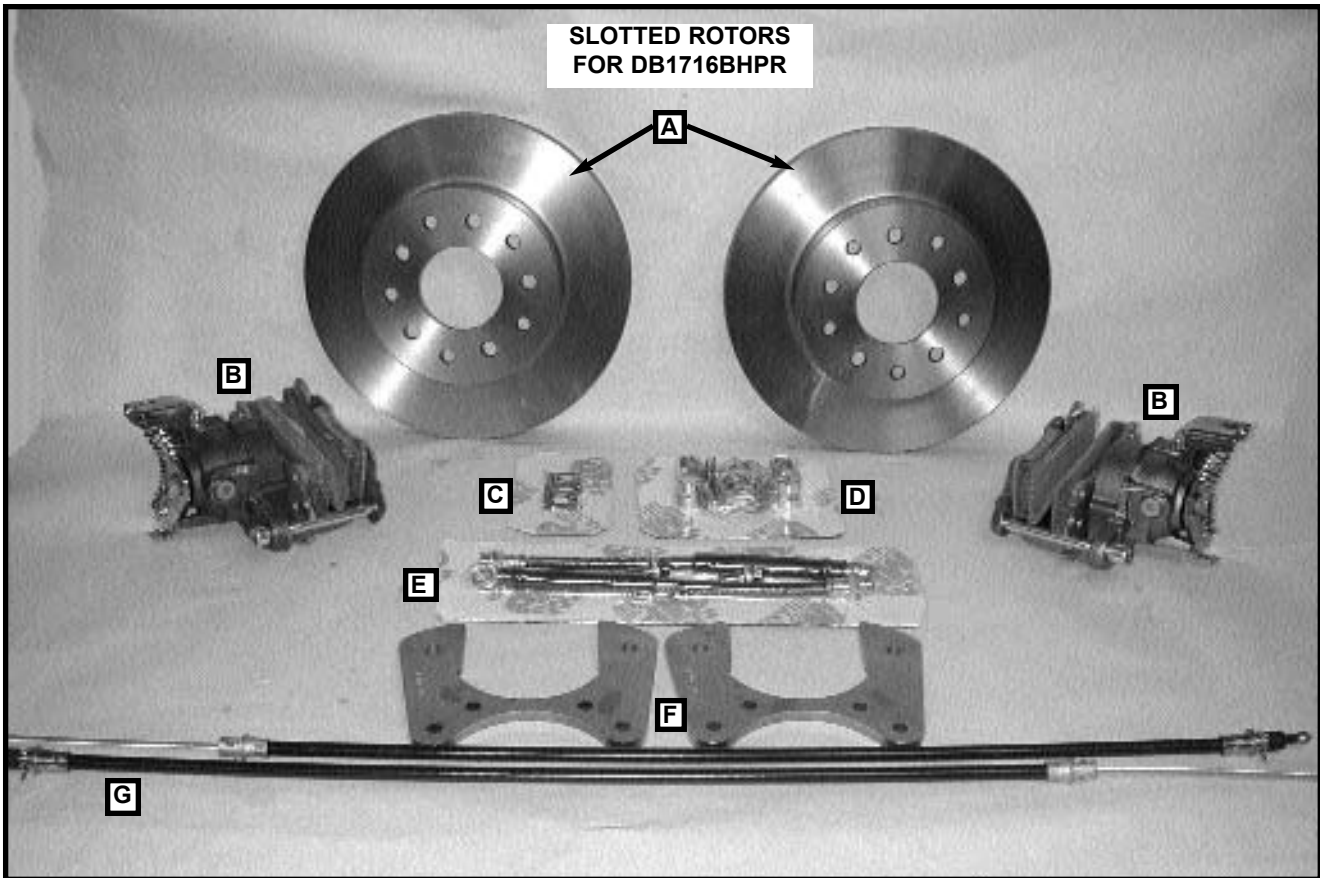

PARTS LIST

- A) (2) RT85774M ROTOR, REAR, MULTI PATTERN
MOD. RT85774
- B) (2) CA601819 REAR CALIPER KIT, CADILLAC
USED IN ALL REAR KITS
- C) (1) BR3737K BRACKETS, HOSE CLIPS 1 PAIR
(2) BR3737 BRACKET, HOSE
(2) HW8708 BRAKE HOSE CLIP
- D) (1) AC2005 E-BRAKE REPAIR KIT
(1) HW21119 CABLE KIT, E-BRAKE
(2) HW21126 CLAMP KIT, E-BRAKE
- E) (1) HS36846K HOSE KIT, REAR METRIC
USED IN ALL REAR KITS
CA601819
(2) HS36846 HOSE, 12" LENGTH REAR METRIC BOLTS USED
(2) HW5155 10MM METRIC BOLT COURSE
(4) HW9453 WASHER, COPPER, USED FOR HOSE BOLT
- F) (2) BR1791-1 BRACKET, REAR, CALIPER M
FOR GM & FORD
- G) (2) HWC833 CABLE, EMERGENCY REAR
CONVERSION

**DB1716BR
CONTINUED**

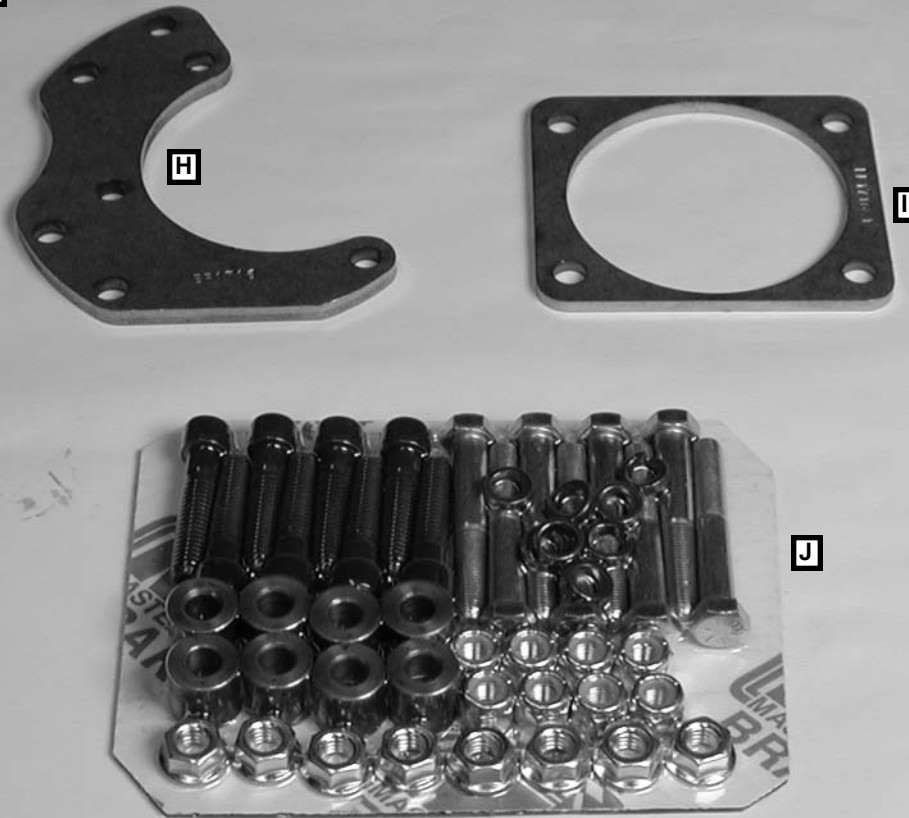

PARTS LIST (CONT.)

- H) (2) BR1716 BRACKET, REAR DISC CHEVY 59-64 FULL-SIZE
- I) (2) FL1716-1 FLANGE 55-64 CHEVY REAR DISC KIT
- J) (1) HW1716HK HARDWARE KIT
 - (8) 37C150KCS 3/8 X 1 1/2 ALLEN CAP SOCKET
 - (8) 37CNWFZ NUT, 3/8-16 WHIZ FLANGE NUT ZINC
 - (8) 37F225HCS8Y BOLT, 3/8-24 X 2 1/4 HCS GR-8 ZINC YELLOW
 - (8) 37FNNEZ NUT, 3/8-24 NYLON INSERT LOCKNUT
 - (8) 37NLHC 3/8 HI-COLLAR L/W
 - (8) BU1716 BUSHING, REAR DISC KIT 9"
SIZE: LENGTH .814 X .747 O.D.
3/8 HOLE

MASTER POWER BRAKES 888-533-1199