



## **WARNING**

Proper operation of your brakes is essential for your safety and the safety of others. Any brake service should be performed ONLY by persons experienced in the installation and proper operation of brake systems. It is the responsibility of the person installing any brake component or kit to determine the suitability of the component or kit for the particular application. After installation and before operating your vehicle, be sure to test the function of the brakes under controlled conditions.

**DO NOT DRIVE WITH UNTESTED BRAKES!**

**FOR TECHNICAL ASSISTANCE CALL:**

**888-533-1199**

**MONDAY - FRIDAY**

**8:00 AM TO 5:00 PM EST**

## **IMPORTANT**

Take time to read all the literature that came with this kit. Check the provided list of parts against what you received to ensure all parts are present. While this kit was designed to make the process of changing brake parts as simple as possible. **NOTE: WITH SOME KITS IT MAY BE NECESSARY TO MAKE MINOR CHANGES TO YOUR CAR!**

**READ ALL WARRANTY DISCLAIMERS AND RETURN POLICIES INCLUDED IN THIS KIT PRIOR TO INSTALLATION!**

# **MASTER POWER BRAKES**

110 CROSSLAKE PARK RD. MOORESVILLE, N.C. 28117

[www.mpbrakes.com](http://www.mpbrakes.com)



# DB1528 SERIES 71-73 MUSTANG/COUGAR

IT'S MORE THAN BRAKES...IT'S CONFIDENCE!

## INSTALLATION INSTRUCTIONS



## MASTER POWER BRAKES

110 CROSSLAKE PARK RD MOORESVILLE N.C. 28117

[www.mpbrakes.com](http://www.mpbrakes.com) 704-664-8866



REVISED 040302

## INSTALLATION INSTRUCTIONS

### INCLUDED COMPONENTS

Your disc brake conversion kit will contain the following components:

1. Caliper brackets
2. Calipers with pads
3. Rotors
4. Bearings, seals
5. Dust caps
6. Mounting hardware
7. Caliper hoses
8. Caliper pad spacer

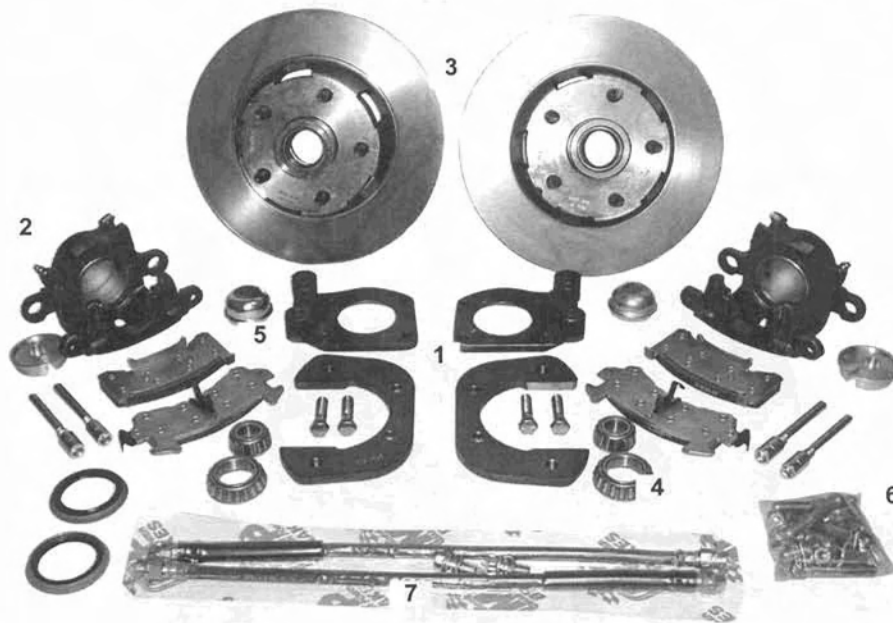

### INSTALLATION

Installation of the disc brake kit will require the use of the following tools:

3/8" ratchet drive set  
Box end wrench set  
Pliers  
Line flaring tool

Mallet  
Ball joint fork  
Screwdriver  
Line bending tool

Flare wrench set  
Drum brake tool  
Snips

Always refer to the vehicle owners manual for the correct torque specifications when installing this kit

**THIS KIT IS DESIGNED TO BOLT TO ORIGINAL DRUM BRAKE SPINDLES  
WITH THE CALIPERS MOUNTED TOWARD THE FRONT OF THE CAR**

1. If you are performing the installation with a jack, be sure that the parking brake is set and that the rear wheels are chocked. Support the front of the vehicle with jack stands. Never work on sloping ground.
2. If you are using a lift, raise the vehicle to a comfortable working height.
3. Remove the front wheels.
4. Unbolt all the drum brake components including the backing plate so that only the bare spindle remains.

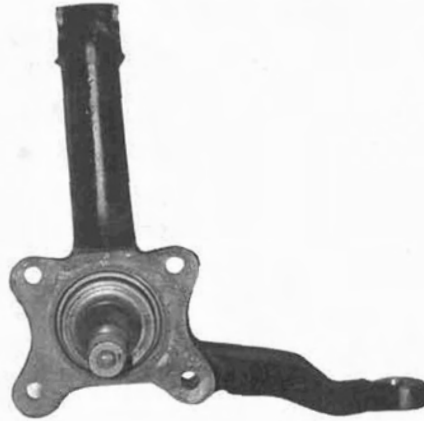

5. Bolt the cast iron bracket onto the spindle as shown below. Use the 4 supplied grade 8 bolts.



Cast iron bracket

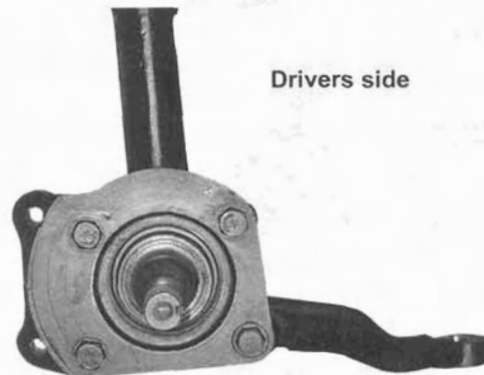

Front of car

6. Bolt the steel caliper bracket to the cast iron spindle bracket as shown below.

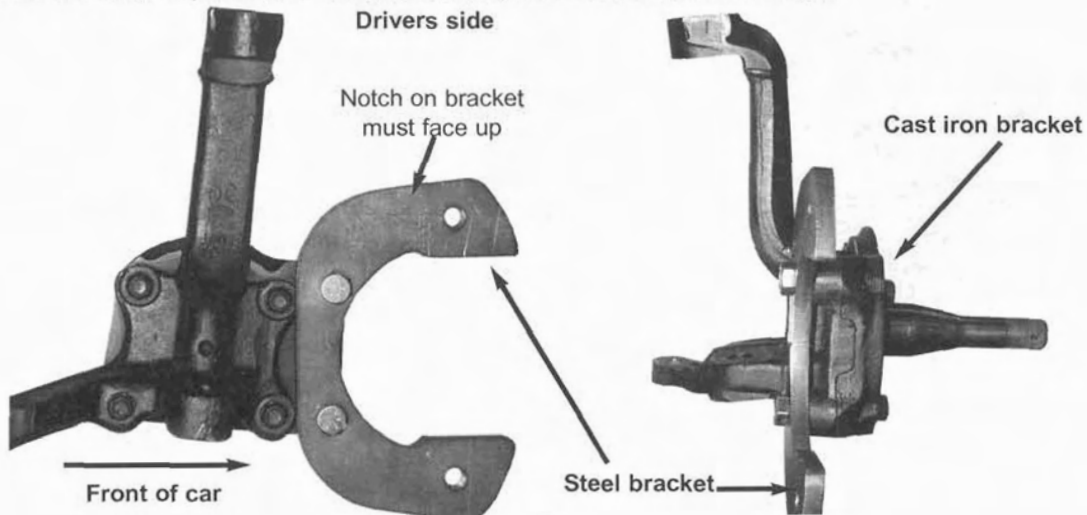

7. Pack the bearings with a high quality bearing grease.
8. Install the larger inner bearing into the rotor followed by the grease seal. Be sure to carefully seat the grease seal fully into the rotor.

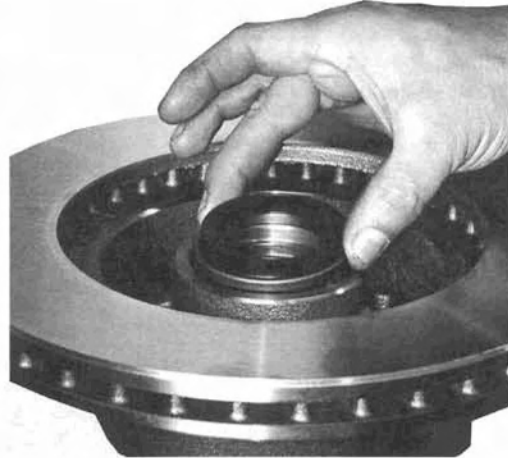
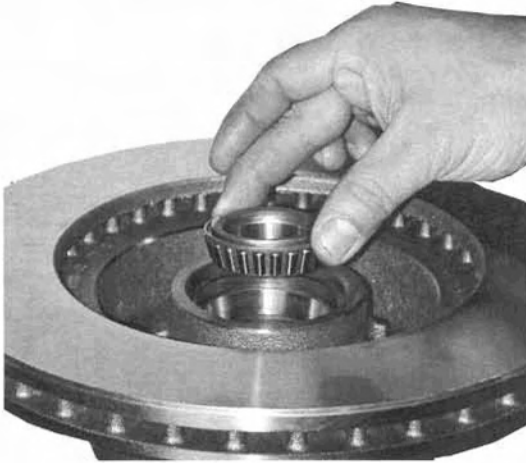

9. Install the aluminum pad spacer into the caliper as shown. Install the pads into the caliper.

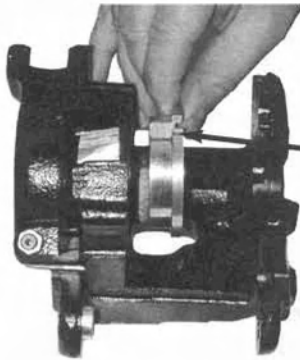

Slot on spacer faces  
up for pad clip

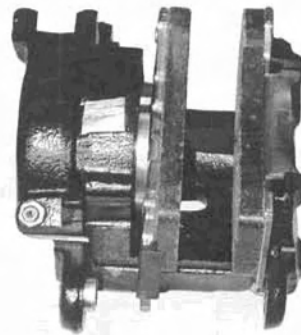

10. Mount the rotor onto the spindle followed by the outer wheel bearing, keyed washer and spindle nut. Be sure to pack the bearing with grease.

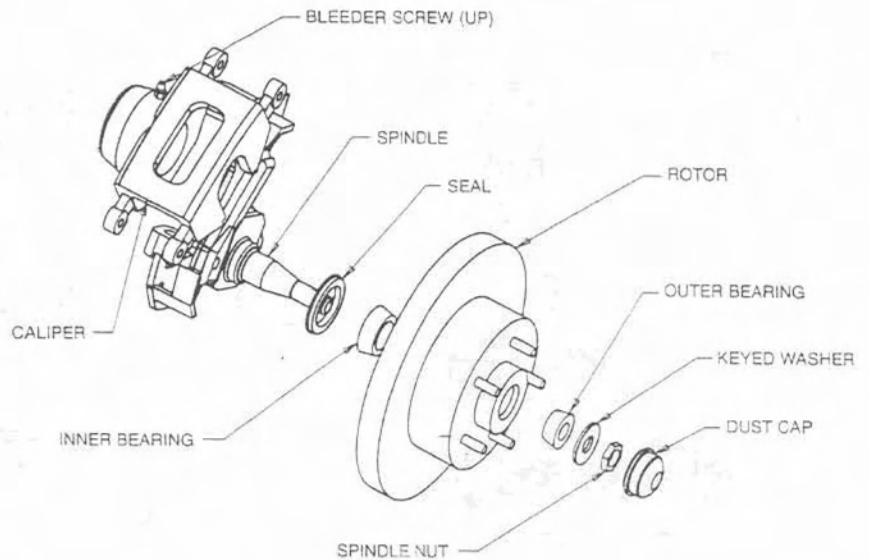
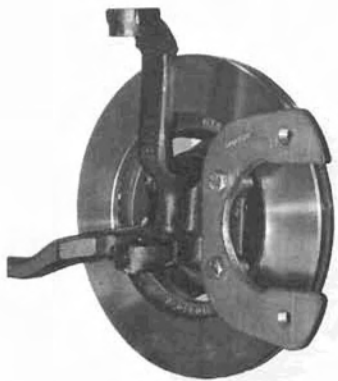

11. Mount the caliper onto the steel cradle with the bleeder screw facing up and the rotor between the pads. Use the threaded caliper bolts to attach the caliper to the cradle. Be sure to install the steel bushings into the caliper to hold the mounting bolt in place.

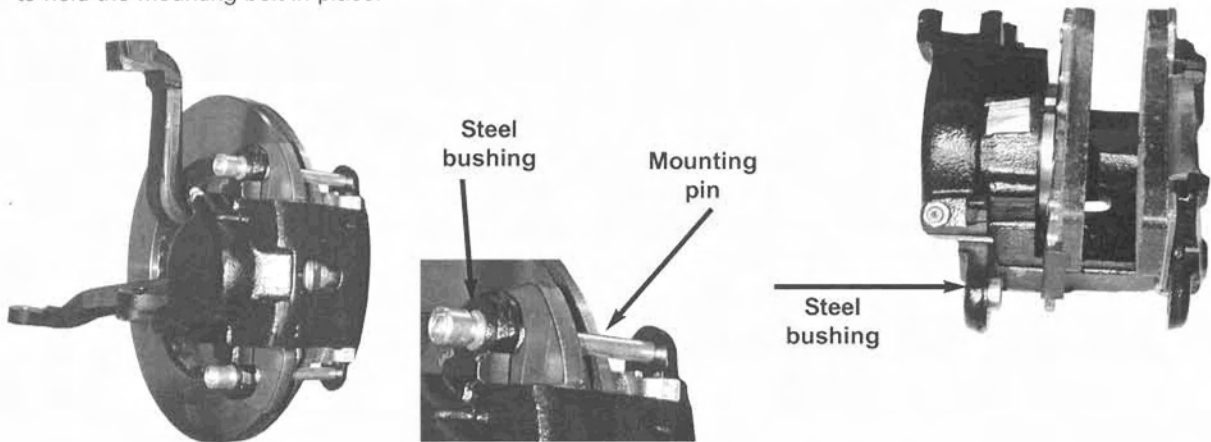

12. This completes one side of the car. Repeat the process on the other side. Remember: The calipers mount toward the front and the bleeder screws must be on top.

## MANUAL MASTER INSTALLATION:

1. Disconnect the master cylinder push rod from the brake pedal.
2. Remove the old master cylinder.
3. Using the two holes which line up with the larger hole, install the new master.
4. Attach the master cylinder push rod to the pedal with the supplied clevis attachment.
5. Place the proportioning valve bracket onto one of the nuts that holds the master and tighten.
6. Mount the valve to the bracket.
7. Run the two supplied pre-bent lines from the master to the valve.
8. Run hard line from the valve to the front and rear part of the braking system as per the valve diagram.

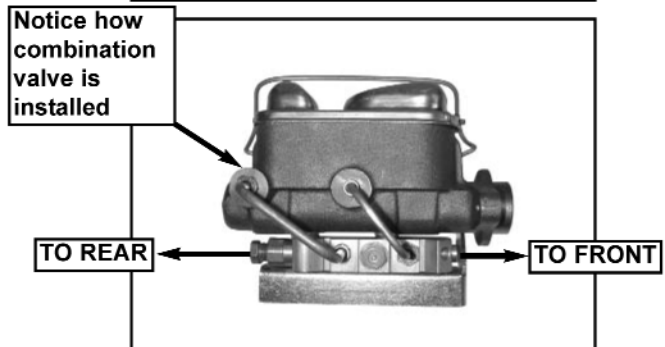
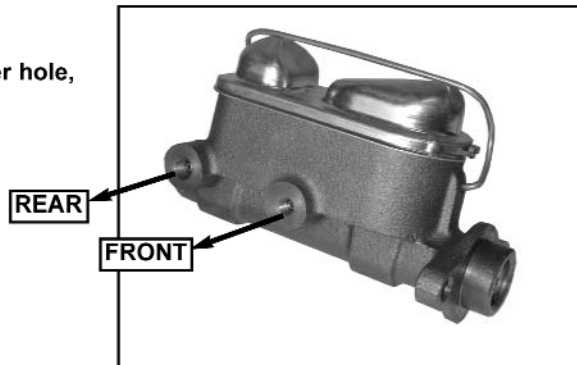

**NOTE:** When running lines to the front, you can plug one of the outlets on the valve (to front) and splice the one brake line to front calipers. You do not need to run two separate lines to the combination valve.

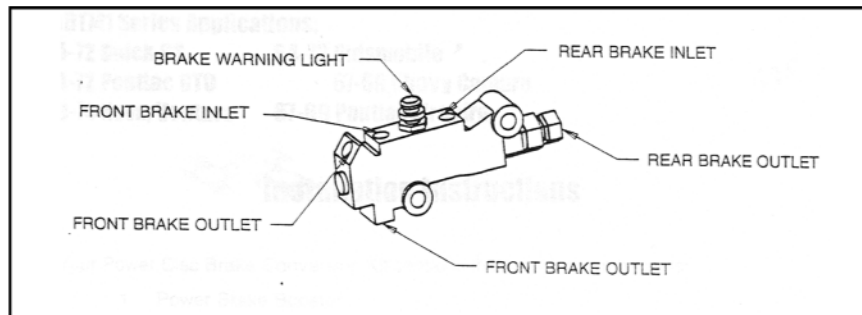

**DB1528MNS**  
**DISC KIT, 71-73 MAN. MUSTANG SINGLE PISTON**  
**PARTS LIST**

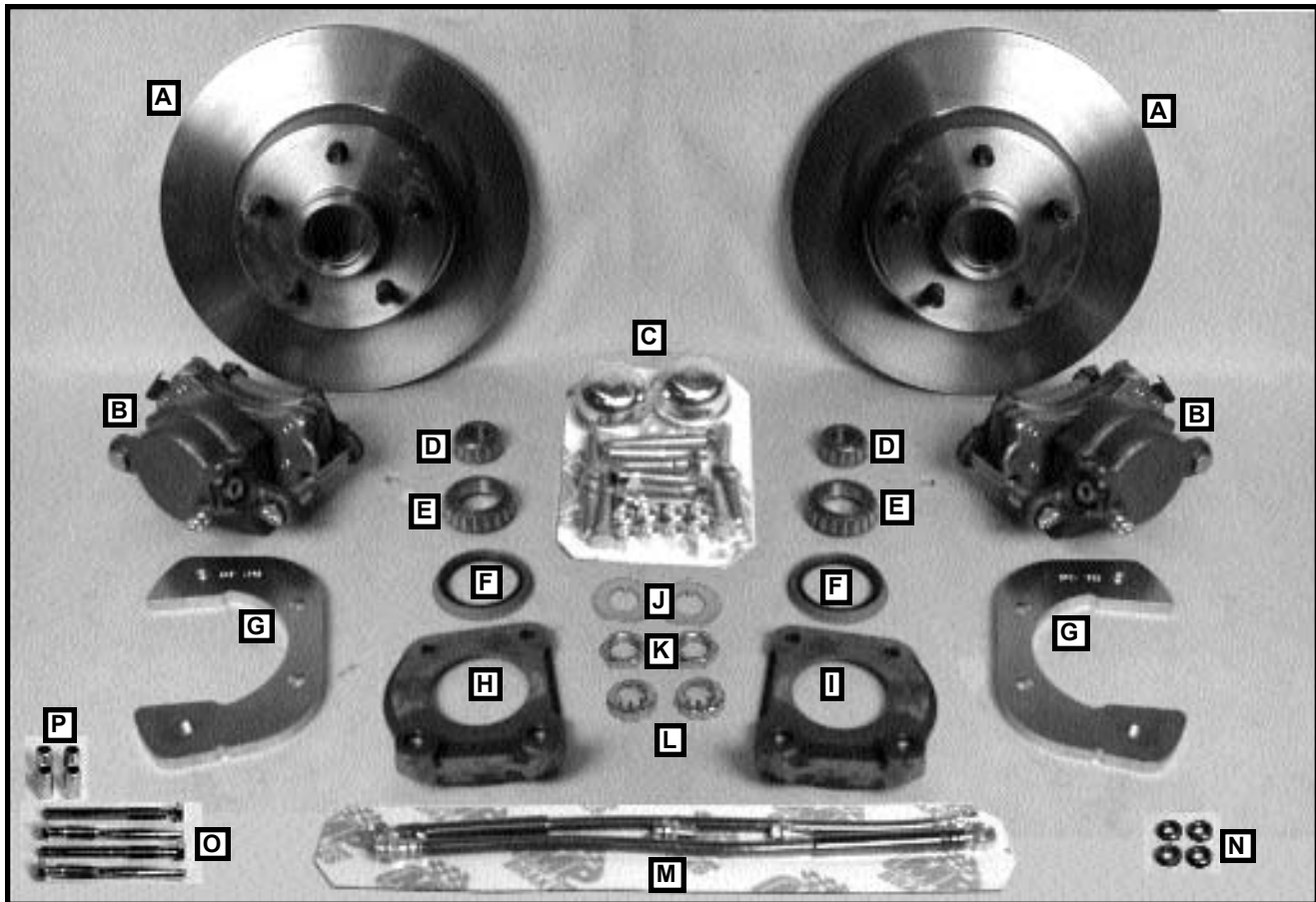

**PARTS LIST**

- A) (2) RT141019 ROTOR, FRONT, 68-73 MUSTANG
- B) (2) CA412829 CALIPERS, GM SMALL 82-97 S-10
- C) (1) HW1522HK HARDWARE KIT
  - (2) 12R100PCOZ COTTER PIN, 1/8 X1"
  - (6) 37F150HCS8Y BOLT, 3/8-24 X 1 1/2 HCS GR-8 YELLOW ZINC
  - (2) 37F250HCS8Y BOLT, 3/8-24 X 2 1/2 HCS GR-8 ZINC YELLOW
  - (8) 37FNNEZ NUT, 3/8-24 NYLOCK
  - (4) 43C175HCS8Y BOLT, 7/16-14 X 1 3/4 HCS GR-8 ZINC YELLOW
  - (4) 43NLOCZ\_DOM WASHER, LOCK, 7/16 SPLIT DOMESTIC, ZINC YELLOW
  - (2) HW4001 CAPS, DUST, 45.2MM /1 25/
- D) (2) HWA2 BEARING, OUTER
- E) (2) HWA6 BEARING, INNER
- F) (2) HW6815 SEAL, ROTOR, SEAL
- G) (2) BRCA1522 BRACKET, CALIPER MUSTANG 64 1/2 -73
- H) (1) BR1502L BRACKET, LEFT, 64-66 MUSTANG 4-PISTON
- I) (1) BR1502R BRACKET, RIGHT, 64-66 MUSTANG 4-PISTON
- J) (2) HW618029 WASHER, SPINDLE FORD MUSTANG LARGE
- K) (2) HW615074 NUT, SPINDLE
- L) (2) HW615075 RETAINER, SPINDLE NUT
- M) (1) HS5157K HOSE KIT, 18" HOSES 10MM
  - (2) HS5157 HOSE, 18" 10MM HOSE
  - (4) HW21206 WASHER, COPPER USED FOR METRIC HOSE BOLT
  - (2) HW5155 10MM METRIC BOLT COURSE
- N) (4) BU1702-2 BUSHING STEEL O.D. .750 X .436 TH. .245
- O) (4) RDP4203 PIN, CALIPER, LONG
- P) (4) RDP4209 BUSHING, LONG
- Q) (2) HWA12 BEARING, OUTER ← (NOT SHOWN)
- R) (2) HWA13 BEARING, INNER ← (NOT SHOWN)

CONTINUED  
ON PAGE 2

DB1528M  
CONTINUED



**PARTS LIST (CONT.)**

- S) (1) MC11378M MASTER CYL., MANUAL, FORD 1" BORE,  
3/8 STROKE DUAL RESERVOIR
- T) (1) VL3360K VALVE KIT, W/ FITTINGS
  - (1) 25C175HCS5Z 1/4 X .175 BOLT
  - (1) 25CNNEZ 1/4 COURSE NYLOCK NUT
  - (1) BR1261N BRACKET, VALVE, UNIVERSAL
  - (2) HW105-3 NUT, 3/16 TUBE 3/8-24 THD
  - (1) HW106-3 PLUG, 3/16"
  - (2) HW106-4 PLUG, INVERTED STEEL 1/4" O.D.
  - (1) HW115-37 NUT, 3/16 TUBE 7/16-24 THD RED
  - (1) HW115-38 NUT, 3/16 TUBE 1/2-20 THD BLACK
  - (1) HW115-39 NUT, 3/16 TUBE 9/16-18 THD OLIVE
  - (1) HW1709 PLUG, SWITCH, COMBO VALVE
  - (1) HW210-43 ADAPTOR, BRASS 7/16-3/8M
  - (2) HW300-3 COUPLER 3/16
  - (2) HW300-4 COUPLER 1/4
  - (2) HW300-5 COUPLER 1/2
  - (1) HW3359 PLUG, COMBO VALVE, 4 WHEEL DISC
  - (1) HW702-3 T-FITTING 3/16 X 3/16 X 3/16
  - (1) VL3350 VALVE, COMBO, DISC / DRUM
- U) (1) PR4724 PUSH ROD, FORD

**MASTER POWER BRAKES 888-533-1199**