



WARNING

Proper operation of your brakes is essential for your safety and the safety of others. Any brake service should be performed ONLY by persons experienced in the installation and proper operation of brake systems. It is the responsibility of the person installing any brake component or kit to determine the suitability of the component or kit for the particular application. After installation and before operating your vehicle, be sure to test the function of the brakes under controlled conditions.

DO NOT DRIVE WITH UNTESTED BRAKES!

FOR TECHNICAL ASSISTANCE CALL:

888-533-1199

MONDAY - FRIDAY

8:00 AM TO 5:00 PM EST

IMPORTANT

Take time to read all the literature that came with this kit. Check the provided list of parts against what you received to ensure all parts are present. While this kit was designed to make the process of changing brake parts as simple as possible. **NOTE: WITH SOME KITS IT MAY BE NECESSARY TO MAKE MINOR CHANGES TO YOUR CAR!**

READ ALL WARRANTY DISCLAIMERS AND RETURN POLICIES INCLUDED IN THIS KIT PRIOR TO INSTALLATION!

MASTER POWER BRAKES

110 CROSSLAKE PARK RD. MOORESVILLE, N.C. 28117

www.mpbrakes.com

DB1524M & DB1524MHP

Installation Instructions

WARNING:

Installation of any component or kit should only be performed by persons experienced in the installation and proper operation of disc brake systems. It is also the responsibility of the person installing any brake component or kit to determine the suitability of the component or kit for that particular application.

NOTE:

Before operating the vehicle after installation test the function of the brakes under controlled conditions. Make several stops in a safe area from low speed and gradually work up to normal speeds. **DO NOT DRIVE WITH UNTESTED BRAKES!** Always utilize safety restraints when operating the vehicle.

STEP 1:

1. Check to be sure that your kit has all the necessary parts needed to complete this project! (Use the supplied parts list as a check list.)

STEP 2:

Remove the following components from you car:

Tech tip: Prior to disassembly spray the nuts and bolts that will be removed with a penetrant.

1. If you are performing the installation with a jack, be sure that the parking brake is set and that the rear wheels are chocked. Support the front of the vehicle with jack stands. Never work on sloping ground.
2. If you are using a lift, raise the vehicle to a comfortable working height.
3. Remove the front tires.
4. Next, disconnect the drum brake hoses from the hard line using the appropriate flare wrenches.
5. Now remove all the drum brake components, including backing plates, from the spindles.
6. At this point, clean and inspect spindles, ball joints and tie rod ends for excessive wear or damage, replace at this time if necessary, in preparation for assembly.



STEP 3:

Things to prepare before assembly of the new disc brake kit:

Note: Assembly pictures are shown with the high performance rotors!

1. Grease the bearings. (Use a high quality disc brake bearing grease.)
2. Install the greased inner bearing and the rotor seal onto the rotor. **Note:** The supplied rotors come with races, so you can disregard the races that are with the bearings.
3. Clean the rotors using brake cleaner first, then with soap and water. Dry with a clean towel.

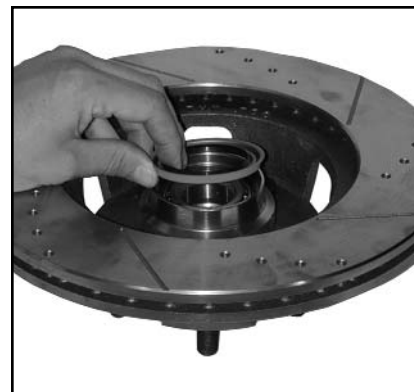

STEP 4:

Installation of disc brake components:

1. Starting with a clean spindle, install the supplied caliper brackets to the front of the spindle. The two threaded holes should mount inward and toward the front of the car (As shown in Figure 2).

Note: If you assemble the rotor onto the spindle and the rotor drags slightly on the cast bracket, then remove the rotor, barely loosen the 4 bolts, that hold the bracket on, and then tap the bracket toward the rear of the car with a rubber mallet. This should help to align any problems due to inconsistencies in spindles!

This side of the bracket will mount flush with the front of the spindle.

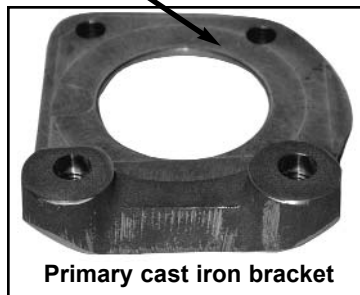

Figure 1

Threaded holes are mounted inward and toward the front of the car.

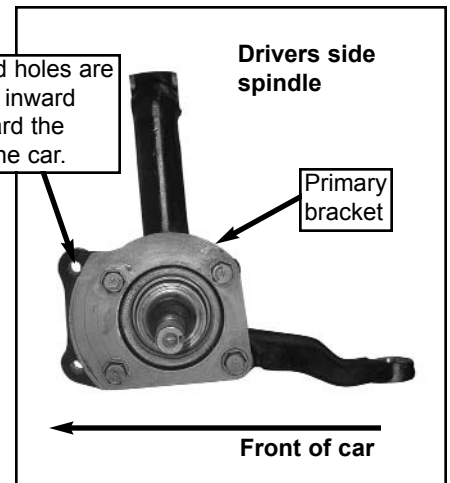

Figure 2

2. Now, bolt the steel secondary caliper bracket to the cast iron primary spindle bracket.



Figure 3

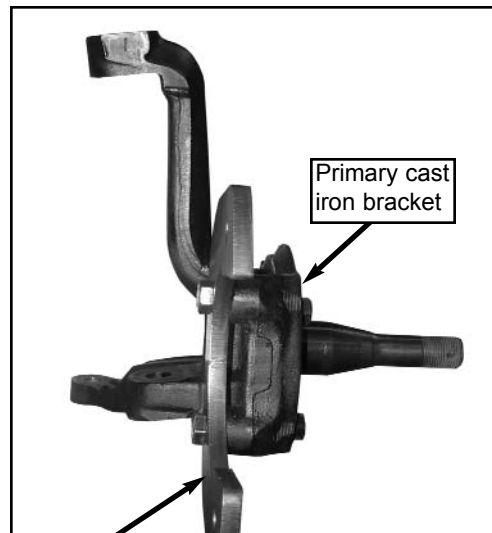

Figure 4

Steel secondary bracket.

3. Slide the rotor onto the spindle (with the greased inner bearing and the rotor seal already installed) followed by the greased outer bearing (As shown in Figure 5), the keyed washer and the spindle nut (As shown in Figure 6). Tighten the spindle nut until rotor moves freely but is not loose. Then install the spindle nut retainer and the cotter pin to secure.

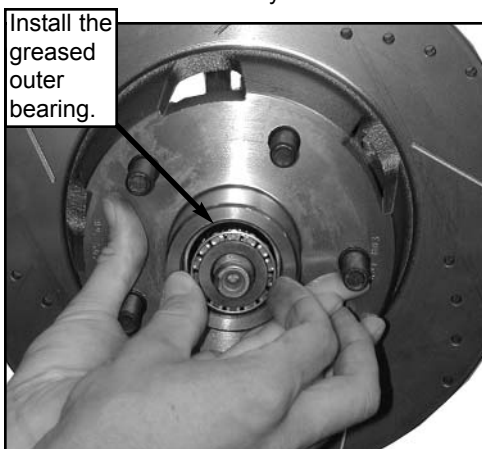

Figure 5

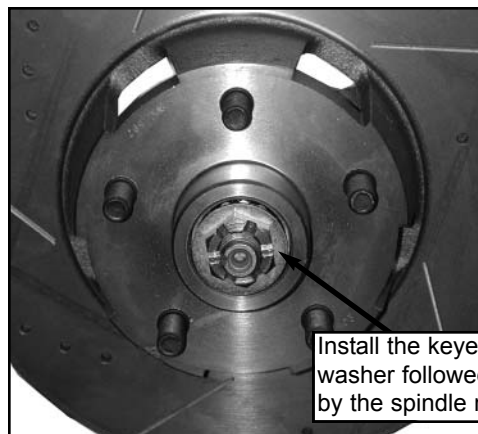

Figure 6

Install the keyed washer followed by the spindle nut.

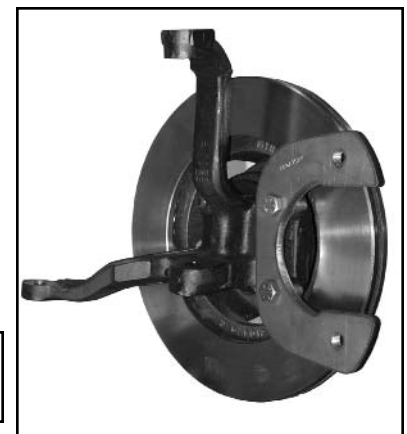
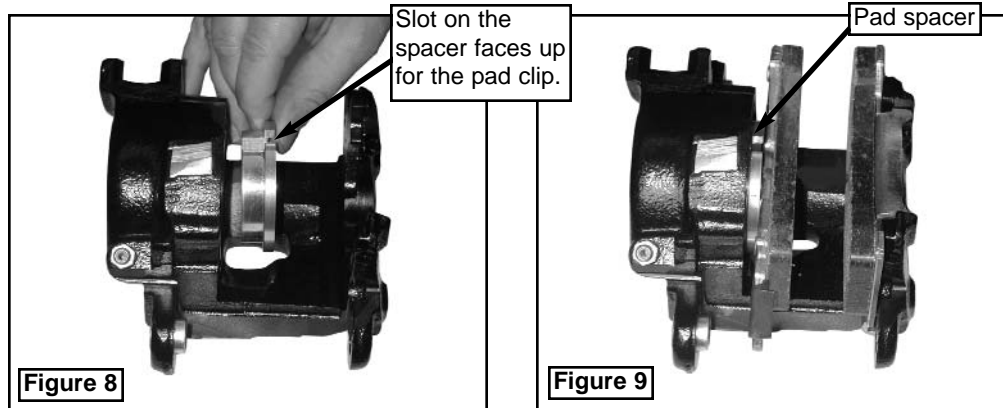

Figure 7

Step 4: (Cont.)

4. Install the provided aluminum pad spacer into the caliper (**as shown in Figure 8**) and then install the pads into the caliper.



5. Mount the caliper to the caliper bracket by sliding the caliper over the rotor and into the cradle of the caliper bracket. **Make sure the bleed screw is above the brake hose connection!** Then, using the supplied caliper mounting bolts, tighten the caliper to the bracket by threading the bolts into the bracket. Use the steel bushings for the caliper bolts, this will help to properly space the caliper and hold it in place.

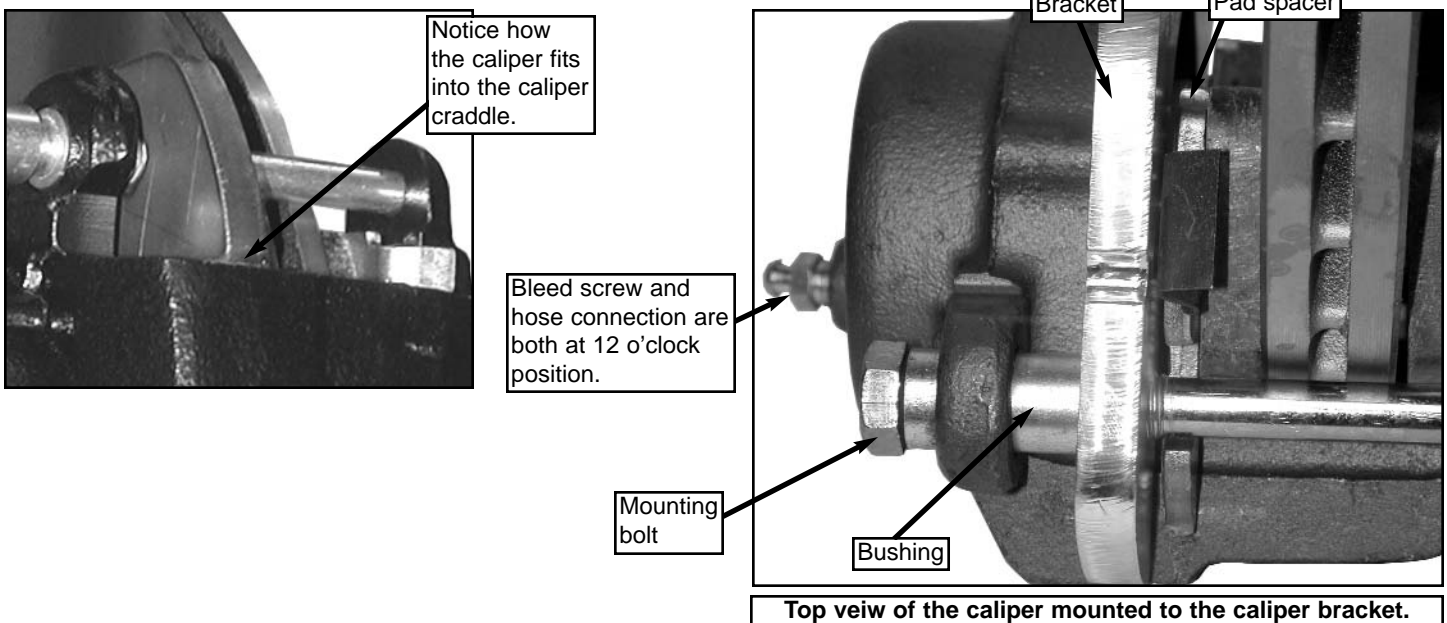

6. Attach the brake hose to the caliper using the supplied banjo bolt. Also be sure to include the two sealing washers on each side of the hose end.
7. Then connect the new brake hose to the system at the frame, in the same location that the drum hoses came off. (**Note: In some cases it may be necessary to relocate the hard line!**)
8. Now repeat this process on the other side.

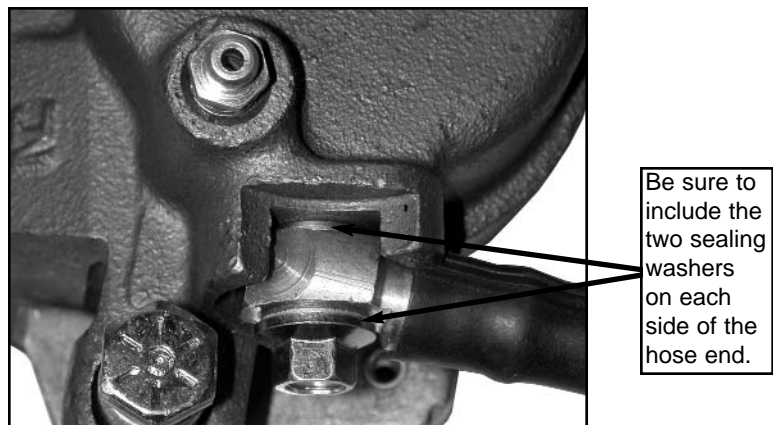

Master Power Brakes
888-533-11993

DB1524M
DISC KIT, 64-73 MUSTANG MANUAL KIT
PARTS LIST

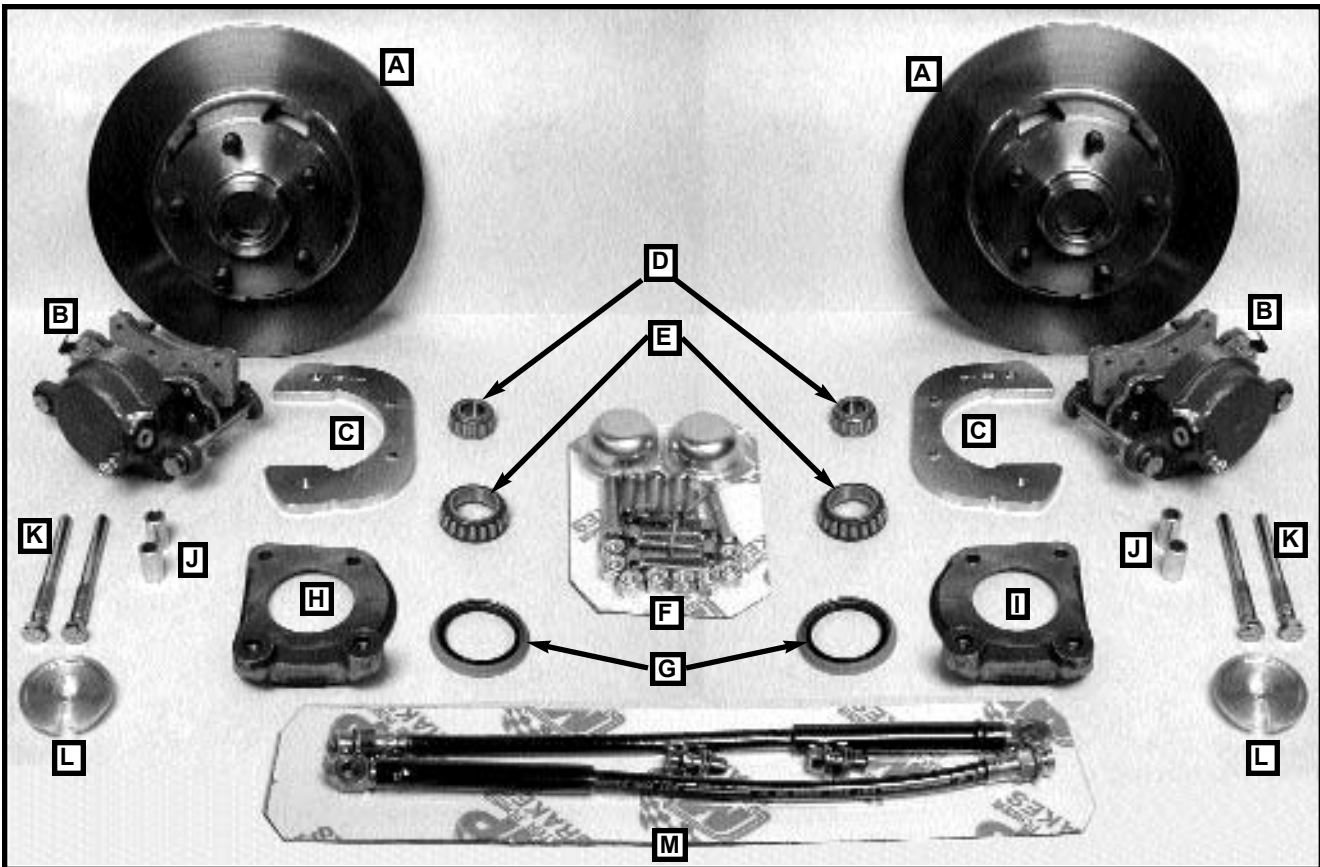

PARTS LIST

- A) (2) RT85502 ROTOR, 64-66 MUSTANG 4 PISTON
- B) (2) CA412829 CALIPERS GM SMALL 82-97 S-10
- C) (2) BRCA1522 BRACKET, CALIPER MUSTANG 64 1/2-73
- D) (2) HWA2 BEARING, OUTER
- E) (2) HWA6 BEARING, INNER
- F) (1) HW1524K HARDWARE KIT
 - (2) 12R100PCOZ COTTER PIN, 1/8 X 1"
 - (6) 37F125HCS8Y BOLT, 3/8-24 X 1 1/4 HCS GR-8 ZINC YELLOW
 - (2) 37F225HCS8Y BOLT, 3/8-24 X 2 1/4 HCS GR-8 ZINC
 - (8) 37FNNEZ NUT, 3/8-24 NYLOCK
 - (4) 43C150HCS8Y BOLT, 7/16 X 14 X 1 1/2 HCS
 - (2) HW4001 CAPS, DUST, 45.2MM /1 25/
- G) (2) HW6815 SEAL, ROTOR, SEAL
- H) (1) BR1502L BRACKET, LEFT, 64-66 MUSTANG 4 PISTON
- I) (1) BR1502R BRACKET, RIGHT, 64-66 MUSTANG 4 PISTON
- J) (4) RDP4209 BUSHING, LONG
- K) (4) RDP4203 PIN, CALIPER LONG
- L) (2) AD412526 ADAPTOR, PAD SPACER
- M) (1) HS77225K HOSES, METRIC 79-81 GM
 - (2) HS77225 HOSE, BRAKE, 79-81 CAMARO 16" HOSE
 - (2) HW5155 10MM METRIC BOLT COURSE
 - (4) HW9453 WASHER, COPPER, USED FOR HOSE BOLT

DB1524M
CONTINUED

N



P



Q



O



PARTS LIST (CONT.)

- N) (1) MC11378M MASTER CYL. MANUAL, FORD 1" BORE, 3/8" STROKE DUAL RESERVOIR
- O) (1) VL3360K VALVE KIT, W/ FITTINGS
 - (1) 25C175HCS5Z 1/4 X .175 BOLT
 - (1) 25CNNEZ 1/4 COURSE NYLOCK NUT
 - (1) BR1261N BRACKET, VALVE, UNIVERSAL
 - (2) HW105-3 NUT, 3/16 TUBE 3/8-24 THD
 - (1) HW106-3 PLUG, 3/16"
 - (2) HW106-4 PLUG, INVERTED STEEL 1/4" O.D.
 - (1) HW115-37 NUT, 3/16 TUBE 7/16-24 THD RED
 - (1) HW115-38 NUT, 3/16 TUBE 1/2-20 THD BLACK
 - (1) HW115-39 NUT, 3/16 TUBE 9/16-18 THD OLIVE
 - (1) HW1709 PLUG, SWITCH, COMBO VALVE
 - (1) HW210-43 ADAPTOR, BRASS 7/16-3/8M
 - (2) HW300-3 COUPLER 3/16
 - (2) HW300-4 COUPLER 1/4
 - (2) HW300-5 COUPLER 1/2
 - (1) HW3359 PLUG, COMBO VALVE, 4 WHEEL DISC
 - (1) HW702-3 T-FITTING 3/16 X 3/16 X 3/16
 - (1) VL3350 VALVE, COMBO, DISC / DRUM
- P) (1) PR21368 PUSH ROD, FROM A 11862 M MANUAL FORD ROD
- Q) (1) BU1521 BUSHING, NYLON, PEDAL MUSTANG

MASTER POWER BRAKES 888-533-1199