



WARNING

Proper operation of your brakes is essential for your safety and the safety of others. Any brake service should be performed ONLY by persons experienced in the installation and proper operation of brake systems. It is the responsibility of the person installing any brake component or kit to determine the suitability of the component or kit for the particular application. After installation and before operating your vehicle, be sure to test the function of the brakes under controlled conditions.

DO NOT DRIVE WITH UNTESTED BRAKES!

FOR TECHNICAL ASSISTANCE CALL:

888-533-1199

MONDAY - FRIDAY

8:00 AM TO 5:00 PM EST

IMPORTANT

Take time to read all the literature that came with this kit. Check the provided list of parts against what you received to ensure all parts are present. While this kit was designed to make the process of changing brake parts as simple as possible. **NOTE: WITH SOME KITS IT MAY BE NECESSARY TO MAKE MINOR CHANGES TO YOUR CAR!**

READ ALL WARRANTY DISCLAIMERS AND RETURN POLICIES INCLUDED IN THIS KIT PRIOR TO INSTALLATION!

MASTER POWER BRAKES

110 CROSSLAKE PARK RD. MOORESVILLE, N.C. 28117

www.mpbrakes.com

DB1517BR / DB1517BHPR Rear Disc Kit Parts List

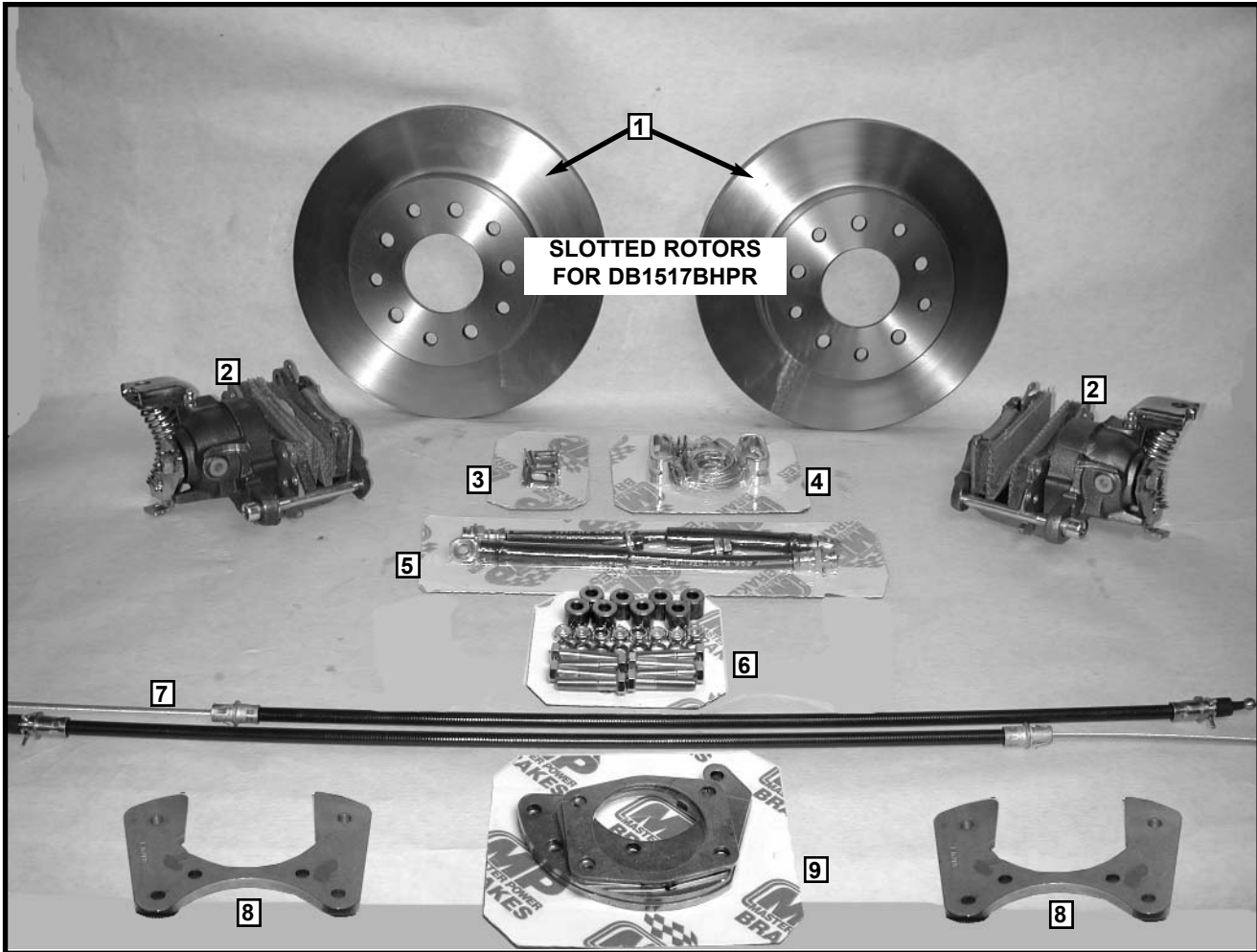

Parts included in the box:

1. (2) Rotors
2. (2) Calipers
3. (1) Hose bracket kit.
4. (1) E-brake repair kit.
5. (1) Rear brake hose kit.
6. (1) Hardware pack.
7. (2) E-brake cables.
8. (2) Secondary brackets (caliper brackets).
9. (1) Pack with axle flanges and primary brackets.
10. (1) Set of instructions.

Master Power Brakes
888-533-1199

DB1517BR & DB1517BHPR

Installation Instructions

WARNING:

Installation of any component or kit should only be performed by persons experienced in the installation and proper operation of disc brake systems. It is also the responsibility of the person installing any brake component or kit to determine the suitability of the component or kit for that particular application.

NOTE:

Before operating the vehicle after installation test the function of the brakes under controlled conditions. Make several stops in a safe area from low speed and gradually work up to normal speeds. **DO NOT DRIVE WITH UNTESTED BRAKES!**

Always utilize safety restraints when operating the vehicle.

STEP 1:

1. Check to be sure that your kit has all the necessary parts needed to complete this project! (Use the supplied parts list as a check list.)

STEP 2:

Remove the following components from you car:

Note: The rear axles must be removed to install this kit!

Tech tip: Prior to disassembly spray the nuts and bolts that will be removed with a penetrant.

1. If you are performing the installation with a jack, be sure that the front wheels are chocked. Support the rear of the vehicle with jack stands. Never work on sloping ground.
2. If you are using a lift, raise the vehicle to a comfortable working height.
3. Remove the rear tires.
4. Disconnect the drum brake hoses from the hard line using the appropriate flare wrenches.
5. Remove the stock Ford drums, brakes and the backing plates from the housing. To do this, you will first need to remove the "T" bolts that hold the backing plates and the axles to the housing.
6. Now pull the rear axles out of the rear end housing by using an axle puller. This will ensure the no damage is done to the axle flange or bearings.
7. Now you can remove the drum backing plate and disconnect the emergency brake.

Remove the nuts from the "T" bolts through these holes in the axle flange.

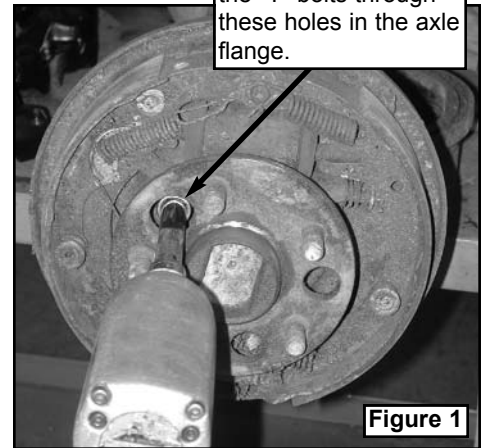

Figure 1

Use an axle puller to remove the axles from the housing.

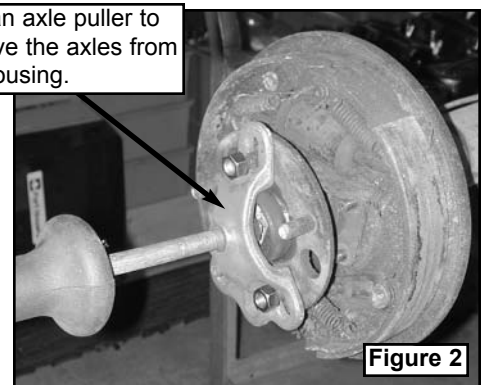
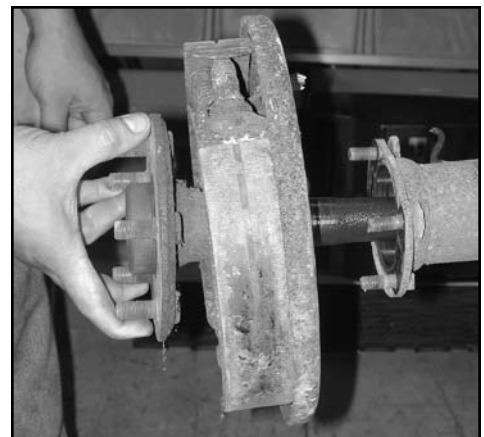

Figure 2



STEP 3:

Things to prepare before assembly of the new disc brake kit:

1. Clean the rotors using brake cleaner first, then with soap and water. Dry with a clean towel.
2. Check to make sure that the axle flange is 6 1/8" in diameter or smaller. **(Trial fit the rotor to the axle flange.)** This will ensure that the rotor will mount flush to the axle flange. **(If the axle flange is larger than 6 1/8", you will need to machine it down to the proper size.)** If you have aftermarket axles consult the manufacturer before machining them.
3. Clean the axle housing flanges and where the axle bearing seats.

Make sure that the axle flange is 6 1/8" in diameter.

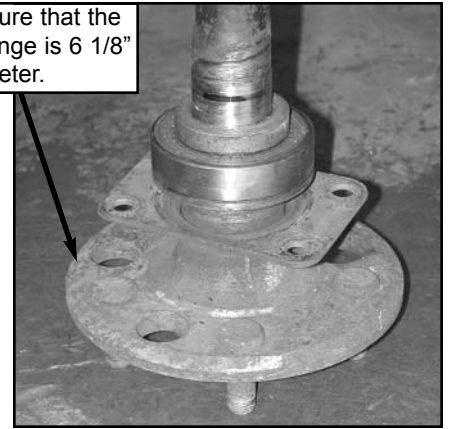

This is what the axle and retaining flange should look like after removal of drum components.

STEP 4:

Installation of disc brake components:

1. Now install the axle spacer plate followed by the axle. (The spacer plate will take the place of the backing plate.)
2. Install the primary bracket so that the calipers will be mounted up and toward the rear of the car.
3. Now reinstall and tighten the bearing retainer nuts.
4. Take the supplied bolts, and install those on the primary bracket. Then use the spacers, that are also provided, and install those onto the bolts.
5. Bolt the secondary bracket to the primary bracket and tighten the nylock nuts.
6. **IMPORTANT:** Check to be sure the axle retaining "T" bolt heads clear the edge of the secondary bracket! If the "T" bolts interfere with the secondary bracket, it will be necessary to trim as shown in the diagram below.

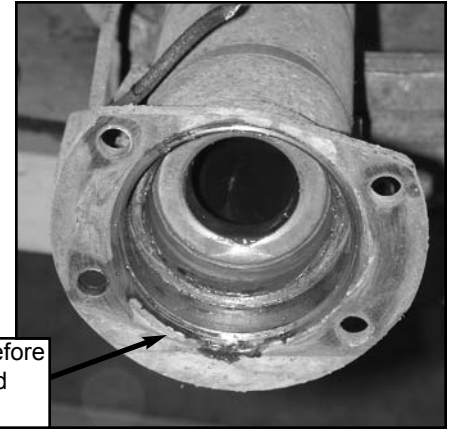

Be sure to clean before reinstalling axle and disc components.

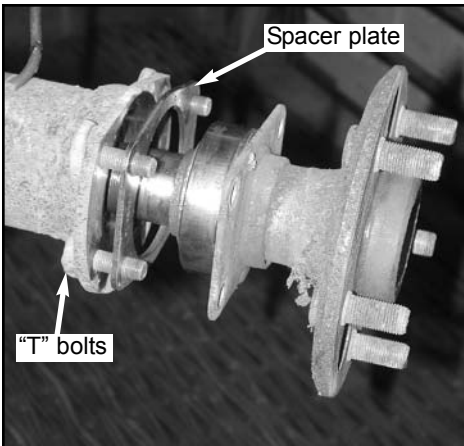

Install the spacer plate followed by the axle.

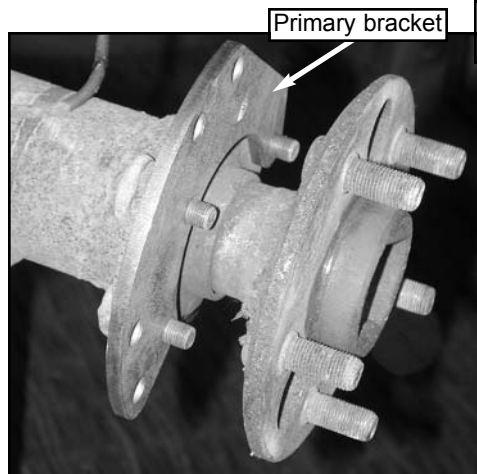

Install the primary bracket so calipers are mounted toward the rear of the car.

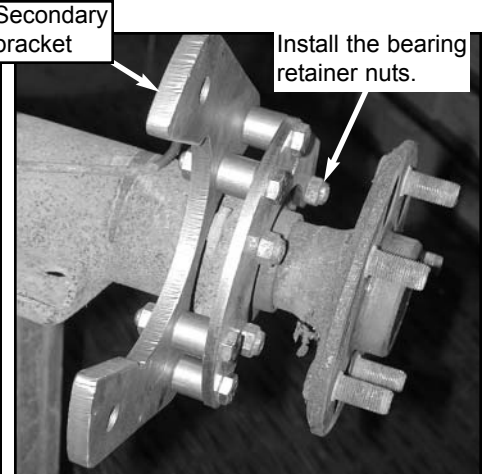

Install the secondary bracket using the supplied bolts and spacers.

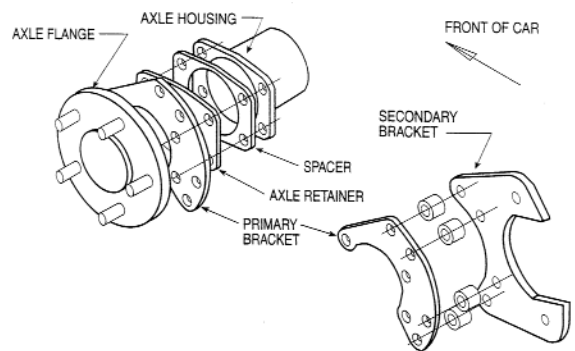
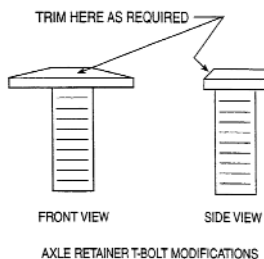

ASSEMBLY VIEW - DRIVERS SIDE

STEP 4: (Cont.)

6. Install the new rotor onto the axle flange. (**Note: Use two or three wheel nuts to hold the rotor in place so you can complete the installation. Only hand tighten the wheel nuts so that you will not damage or warp the rotor.**) Now rotate the rotor and check that the rotor runs true. You also want to be sure that nothing is interfering with the rotation.

Tech Tip: To be sure that the rotor is flush to the axle flange and is all the way over the axle center pilot, insert some strips of paper between the back of the rotor and the axle flange. If you cannot pull the paper out easily, then the rotor is all the way on.

Picture shows optional cross drilled and slotted rotors.

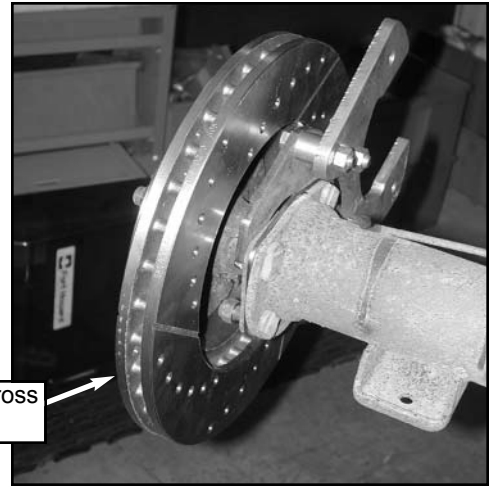

7. Now install the caliper onto the caliper bracket and over the rotor. The caliper should straddle the caliper bracket and the rotor. (**Make sure the bleed screw is facing up!**) Then tighten the caliper bolts to secure. (**Now follow the instructions provided for adjusting these calipers. Failure to do so will prevent you from getting a firm pedal and you will have no rear brake function!**) Be sure to check all clearances before proceeding!

8. Attaching the flexible brake hose to the caliper and then to the hard line. Now attach the E-brake cable to the caliper. The parking brake cables are supplied to bring you to a central point, **It is the customers responsibility to tie the cables into the system!**

9. Bleed the brakes and test for a full pedal. If the back wheels skid before the front you should install a proportional valve to reduce the pressure to the rear brakes.

Make sure the bleed screw is up!

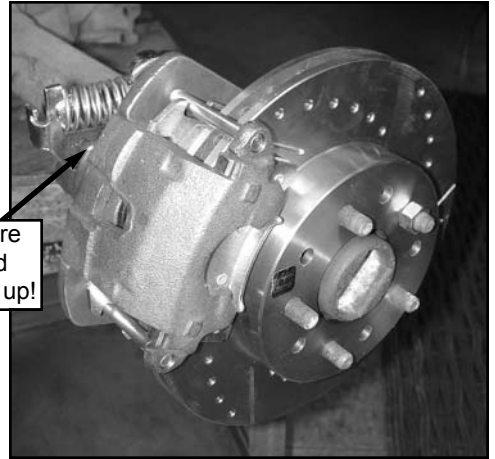

Important: You must use the parking brake mechanism on a regular basis to set the self adjusting calipers. Failure to use the rear parking brake will result in rear brake loss!

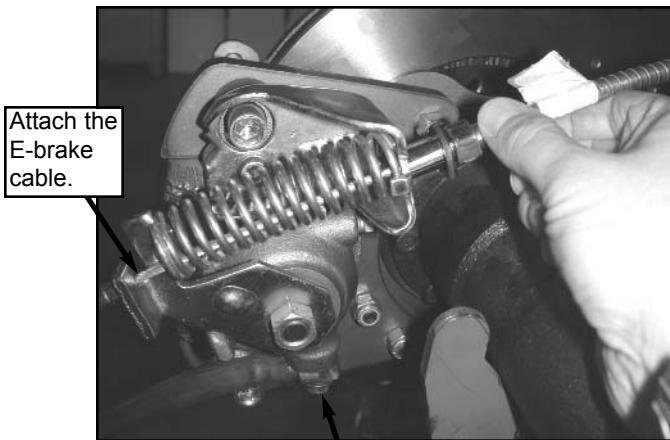

Attach the E-brake cable.

Attach the flexible brake hose to the caliper here!

Spacer

Secondary bracket

Spacer plate

"T" bolt

Primary bracket

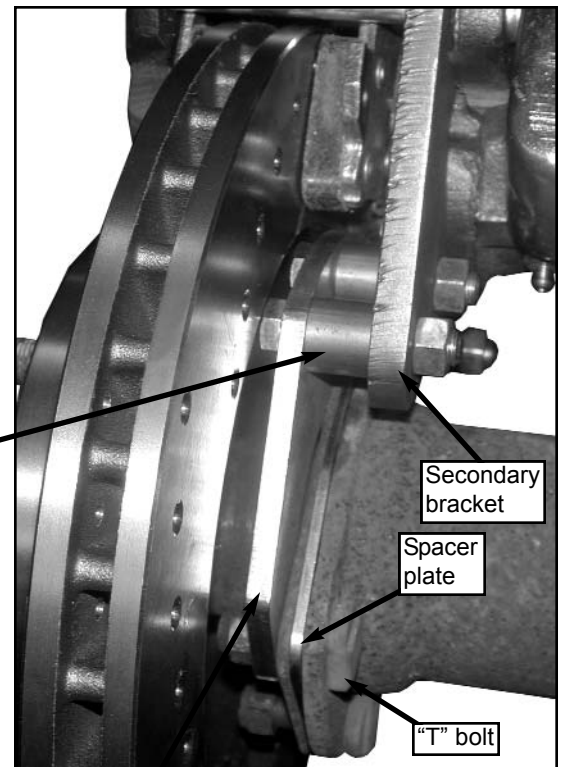

Master Power Brakes
888-533-1199

WARNING

FOR YOUR REAR BRAKES TO OPERATE YOU MUST ADJUST THE REAR CALIPERS

When installing rear disc brakes with calipers that have an internal parking brake you must adjust or set the calipers when installing. Failure to do so will prevent you from getting a firm pedal and you will have no rear brake function. You must also set the parking brake every time you park to keep the calipers adjusted.

The caliper piston is adjusted outward by turning the nut on the lever or by cranking the lever. This ratchets the caliper piston outward moving the pads closer to the rotor. If you do not do this the rear calipers will take up brake fluid but the pads will never squeeze the rotor sending the pedal to the floor.

Only perform this adjustment with the caliper and rotor installed on the car. Start by spinning the rotor. Crank the lever and spin the rotor again to see if there is any drag. Continue cranking the lever until there is a slight drag on the rotor. Attach the parking brake cable. The caliper should now be adjusted. Repeat on the other side.

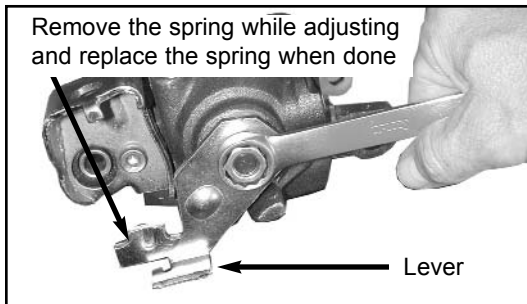

Remove the spring and crank the lever or turn the nut to adjust the piston outward.

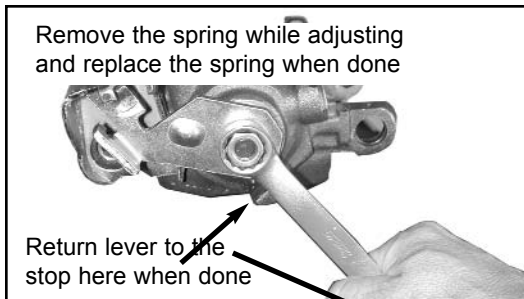

After cranking as far as lever will go rotate it back the other way until you hit the stop and reinstall the spring. The piston will remain out where it was.

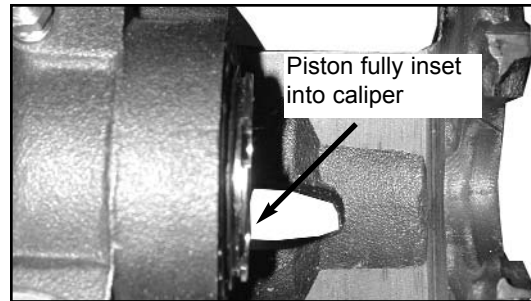

The picture above shows the caliper without any adjustment and the piston fully into the caliper.

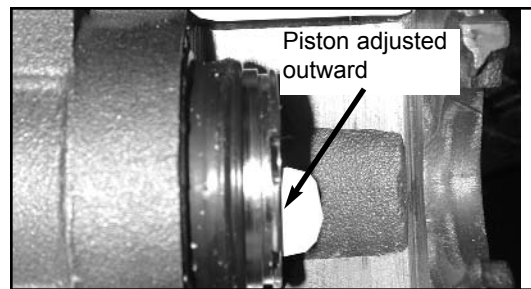

The caliper piston is able to be ratcheted out quite a distance. This will be required as the pads wear. Setting the parking brake when parking will continue to adjust the piston outward and keep the rear calipers functioning.



Helpful hint

To return the lever to the proper rest position use a large screwdriver against the outer lip on the caliper piston to force the piston against the pads firmly. When pressed firmly move the lever against the stop on the caliper casting. Replace the spring and attach cable.

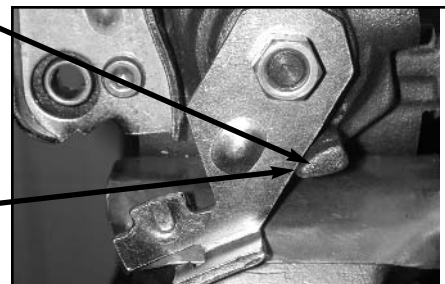

REAR CALIPER ADJUSTMENT

There are some very important things you need to know about this setup. It utilizes Trans Am rear rotors and Eldorado Cadillac rear calipers...

One of the biggest advantages of a disc type brakes is that it has a fool proof self adjuster. Not so with the rear disc GM! The rear calipers adjust off of the parking brake. The parking brake is incorporated into the caliper. **You MUST set the parking brake every time you park your car!** Not many people do that nowadays because it is much easier to just put the transmission in park and walk away! The rear caliper pistons utilize a "one way clutch" or "sprag" inside the caliper piston. When the parking brake is applied the sprag senses when there is .030 or more clearance between the friction material on the inboard side. When the distance is at least .030, the sprag turns inside the piston adjusting it out and keeping the rear brakes adjusted. If you are not setting your parking brake with this setup EVERY time you park your car then two things will happen. #1 - You will start to lose service brake pedal. #2 - The sprag will seize on the inside of the piston and will never work again. NEVER buy these calipers from a rebuilder, because rebuilders use the old piston in most cases and the piston is the reason the calipers were changed to begin with! Master Power Brakes uses only NEW calipers for this application! Also, when replacing rear pads on these calipers, GM says to "get into the vehicle after you have installed the pads and apply the parking brake 60 times".

READ COMPLETELY BEFORE PERFORMING THIS ADJUSTMENT.

The short cut around this is to adjust the brakes out by unhooking the parking brake cable at the lever, removing the spring and the lever itself. Be very careful when performing this. After removing the nut and lever arm the threaded shaft can fall into the caliper. When removing the lever grab the threaded shaft carefully with a pliers so the shaft can't fall in. Now crank the shaft with pliers so the piston moves out to within .030" of the rotor. Re attach the lever arm so it's close to the stop. Once again be careful that you do not push the threaded shaft into the caliper. Hold the top of the threaded shaft with pliers. Tighten the nut. The rear caliper should be adjusted correctly now.

HOLD HERE

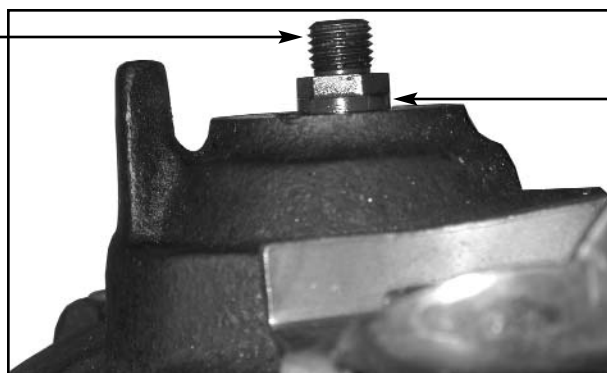

ADJUST HERE