



WARNING

Proper operation of your brakes is essential for your safety and the safety of others. Any brake service should be performed ONLY by persons experienced in the installation and proper operation of brake systems. It is the responsibility of the person installing any brake component or kit to determine the suitability of the component or kit for the particular application. After installation and before operating your vehicle, be sure to test the function of the brakes under controlled conditions.

DO NOT DRIVE WITH UNTESTED BRAKES!

FOR TECHNICAL ASSISTANCE CALL:

888-533-1199

MONDAY - FRIDAY

8:00 AM TO 5:00 PM EST

IMPORTANT

Take time to read all the literature that came with this kit. Check the provided list of parts against what you received to ensure all parts are present. While this kit was designed to make the process of changing brake parts as simple as possible. **NOTE: WITH SOME KITS IT MAY BE NECESSARY TO MAKE MINOR CHANGES TO YOUR CAR!**

READ ALL WARRANTY DISCLAIMERS AND RETURN POLICIES INCLUDED IN THIS KIT PRIOR TO INSTALLATION!

MASTER POWER BRAKES

110 CROSSLAKE PARK RD. MOORESVILLE, N.C. 28117

www.mpbrakes.com

DB1304B/ DB1304BHP
DISC KIT, 70-74 CHALLENGER/ BARRACUDA E-BODY
PARTS LIST

DB1304BHP
 INCLUDES
 SLOTTED
 ROTORS

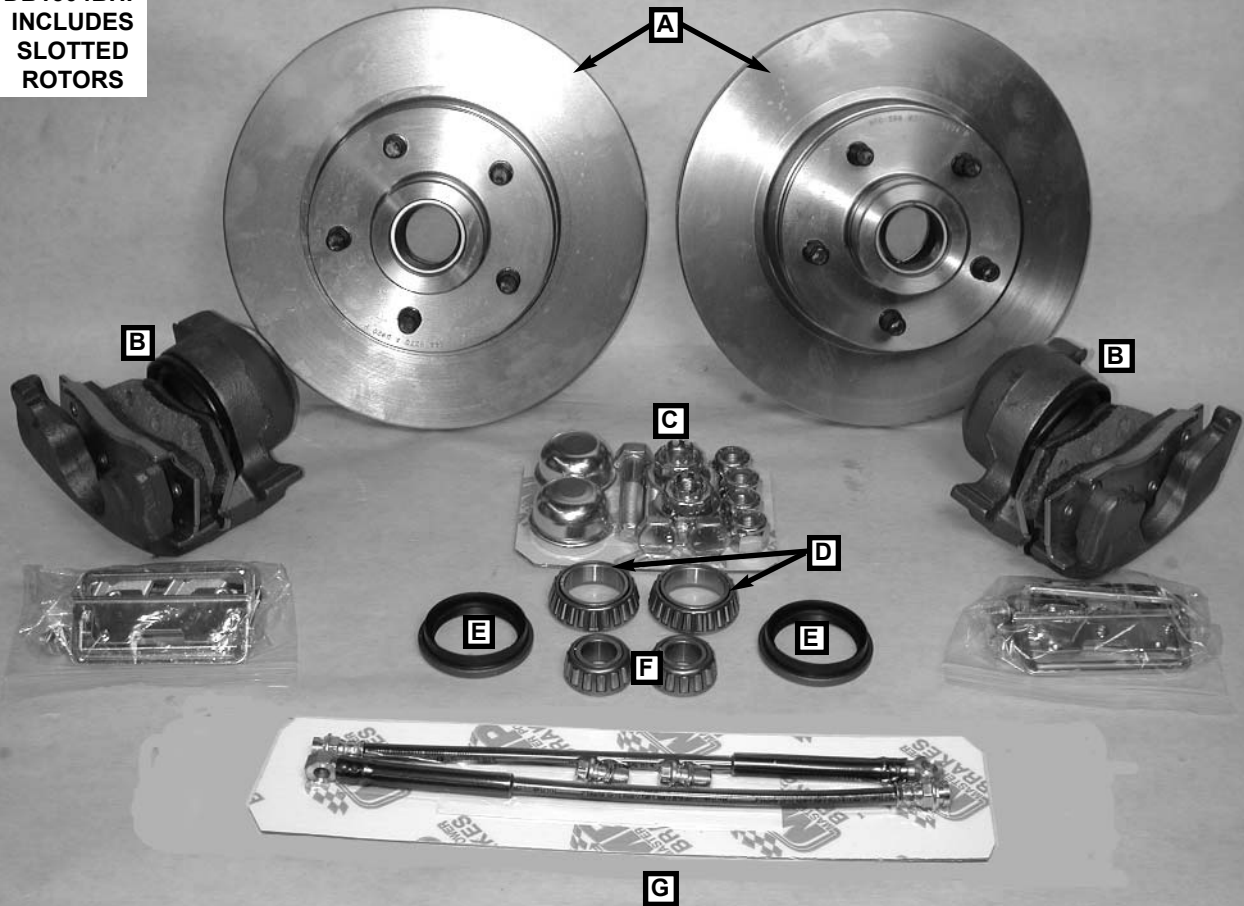

PARTS LIST

- A) (2) RT141145 ROTOR, 73-89 CHRYSLER - RT141145HP ROTORS, SLOTTED***** (SOLD IN PAIRS)*****
- B) (2) CA410304 CALIPER, 76-79 ASPEN, VOL. 73-79
- C) (1) HW1302HK HARDWARE KIT
 - (2) 12R200PCOZ COTTER PIN, 1/8 X 2"
 - (4) 62F275HCS8Y HCS, 5/8-18 X 2.75, GR-8, ZINC
 - (4) 62FNNEZ NUT, 5/8-18, NYLOCK, ZINC
 - (2) HW615005 WASHER, SPINDLE ORG. GM
 - (2) HW615072 NUT, SPINDLE
 - (2) HW615073 NUT, SLOTTED
 - (2) HW4000 DUST CAP, MOPAR
- D) (2) HWA17 BEARING, INNER
- E) (2) HW5121 SEAL, ROTOR
- F) (2) HWA2 BEARING, OUTER
- G) (1) HS88520K HOSE KIT, FRONT, 69-77, 16 GM, SINGLE PISTON CALIPER SET
 - (2) HS88520 HOSE, F, 69-71 CAMARO
 - (2) HW21082 BOLT, HOSE 7/16 X 20 SHORT
 - (4) HW4390 COPPER SEALING WASHER USED W/ 4039 & 4040 CALIPER
- H) (2) SP2627L/R SPINDLES, MOPAR B-BODY, A-BODY MUST USE A-ARMS.
 ONLY 4-1/2 BOLT CIRCLE. ← (NOT SHOWN) →
- I) (2) AC1302D/P DUST SHIELD, MOPAR PAIR ← (NOT SHOWN) →

DB1304 Series

1970-1974 E Body

Plymouth & Dodge

Installation Instructions

WARNING:

Installation of any component or kit should only be performed by persons experienced in the installation and proper operation of disc brake systems. It is also the responsibility of the person installing any brake component or kit to determine the suitability of the component or kit for that particular application.

NOTE:

Before operating the vehicle after installation test the function of the brakes under controlled conditions. Make several stops in a safe area from low speed and gradually work up to normal speeds. DO NOT DRIVE WITH UNTESTED BRAKES!

Always utilize safety restraints when operating the vehicle.

STEP 1:

1. Check to be sure that your kit has all the necessary parts needed to complete this project! **(Use the supplied parts list as a check list.)**

STEP 2:

Remove the following components from you car:

Tech tip: Prior to disassembly spray the nuts and bolts that will be removed with a penetrant.

1. If you are performing the installation with a jack, be sure that the parking brake is set and that the rear wheels are chocked. Support the front of the vehicle with jack stands. Never work on sloping ground.
2. If you are using a lift, raise the vehicle to a comfortable working height.
3. Remove the front tires.
4. At this point, be sure to place the proper support under the lower control arm. Failure to do so will allow the coil spring to blow out when spindle is removed, which could result in vehicle damage and possible serious injury or even death.
5. Next, disconnect the drum brake hoses from the hard line using the appropriate flare wrenches.
6. Now remove the dust cap, cotter pin, spindle nut, spindle washer, bearings and drum from the drum brake spindle.
7. Remove the steering arm from the original drum brake assembly. You will be removing the steering arm from the spindle, but it will remain attached to the lower control arm. (Lower ball joint is on the steering arm.)
8. Now disconnect the upper ball joint from the spindle and remove the spindle.
9. Clean and inspect ball joints and tie rod ends for excessive wear or damage, replace at this time if necessary, in preparation for assembly.

STEP 3:

Things to prepare before assembly of the new disc brake kit:

1. Grease the bearings. (Use a high quality disc brake bearing grease.)
2. Install the greased inner bearing and the rotor seal onto the rotor. **Note: The supplied rotors come with races, so you can disregard the races that are with the bearings.**
3. Clean the rotors using brake cleaner first, then with soap and water. Dry with a clean towel.



STEP 4:

Installation of disc brake components:

1. Start with a clean spindle.
2. Mount the new spindle to the steering arm. The steering arm should still be attached to the lower control arm. (These instructions are applicable for both front and rear steer cars. You may choose front or rear steer depending on what your vehicle requires. The pictures in these instructions may not be exact for your particular application.)
3. Raise the control arm support and attach the upper ball joint. Torque the nut to the correct specifications for your vehicle. (Be sure to insert the cotter pin.)

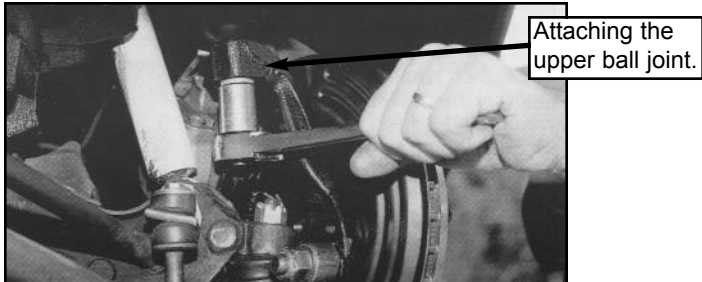
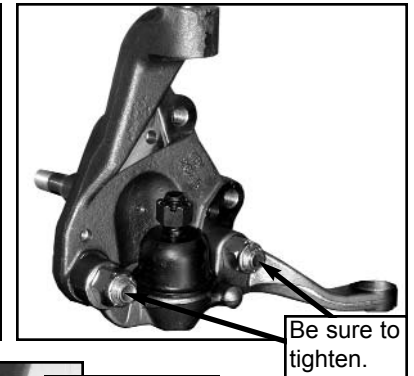
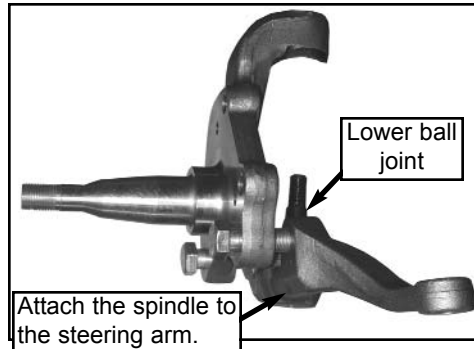
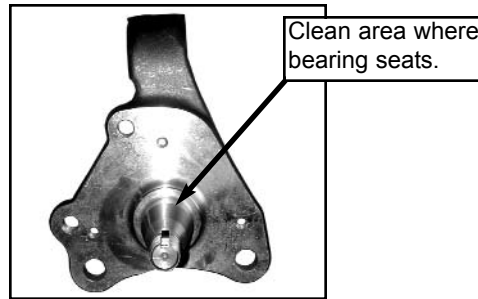

4. Attach the caliper bracket to the spindle with the 1 3/4" supplied bolts. (The spindles and caliper brackets in this kit are match sets and can be mounted on either side of the car as long as you keep the correct spindle with the correct bracket. Spindles and brackets are marked (R) for right and (L) for left.)

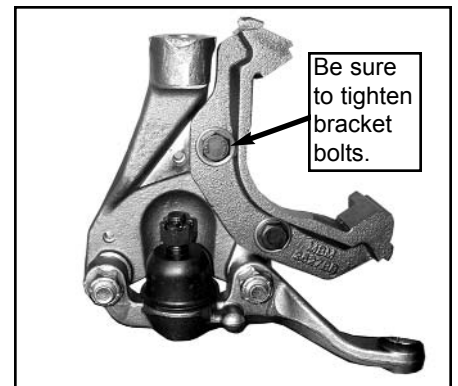
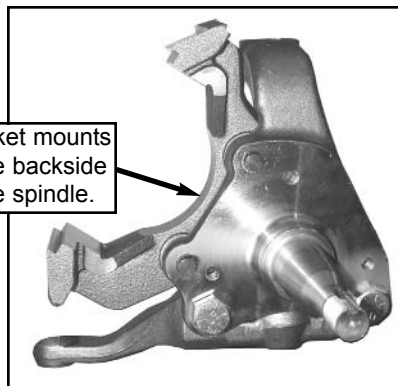
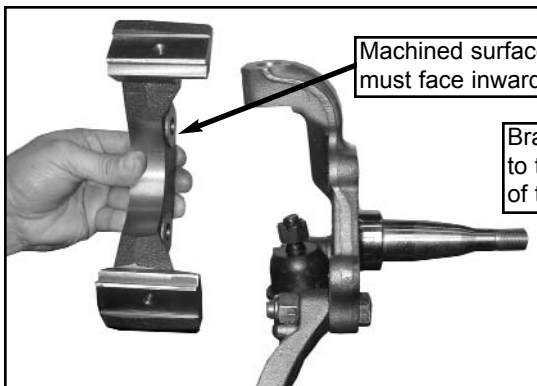

5. Now install the dust shield to the spindle.

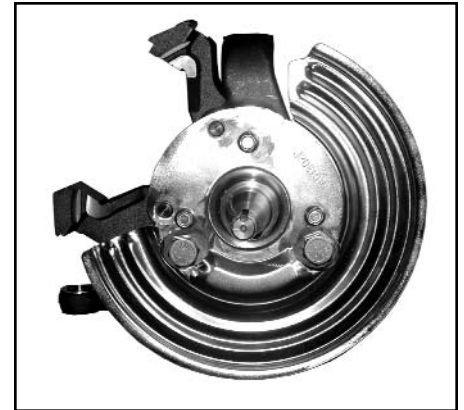
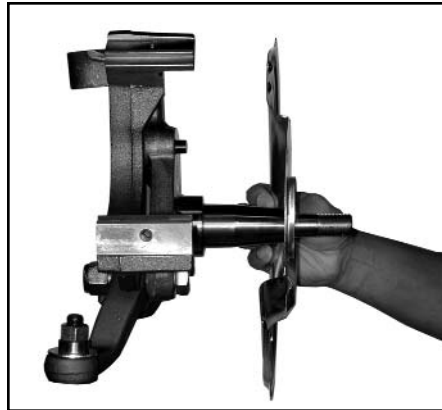

6. Now mount the rotor on to the spindle. **(Greased inner bearing and seal have already been installed.)** Then install the greased outer bearing followed by the spindle washer, spindle nut, spindle nut retainer, the cotter pin and last the dust cap. **(Torque the spindle nut to the proper specifications.)**

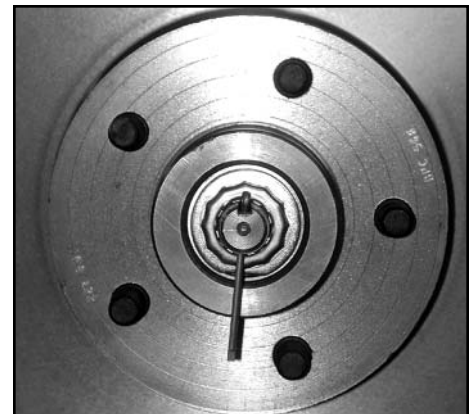
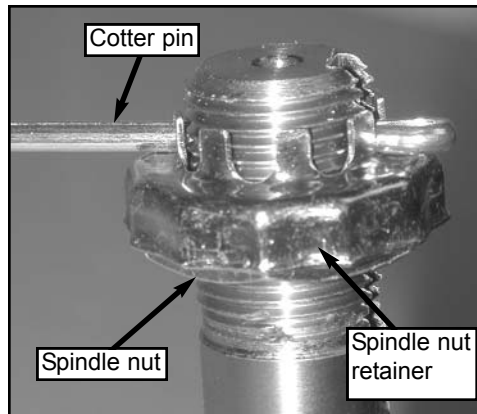
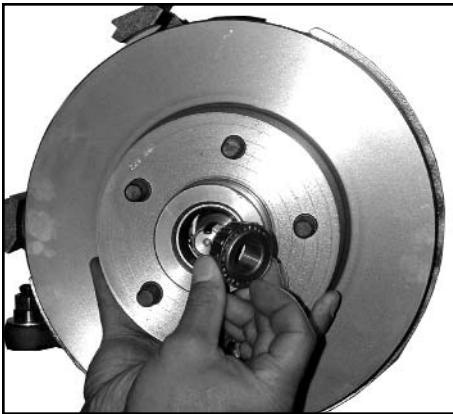

7. Remove the inner pad from the caliper and install correctly in the caliper bracket up against the rotor.

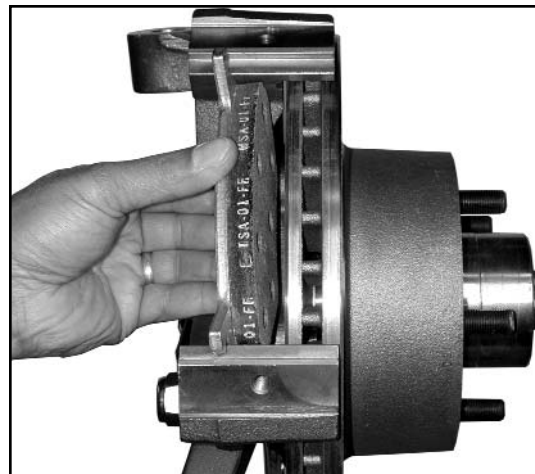

8. Now set the caliper onto the caliper bracket with the piston housing facing toward the inside of the car. **Also make sure that the bleeder screw is facing up!**

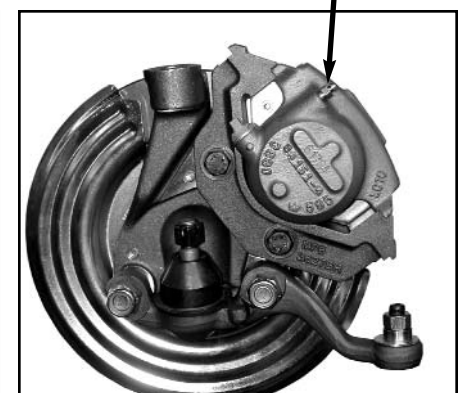
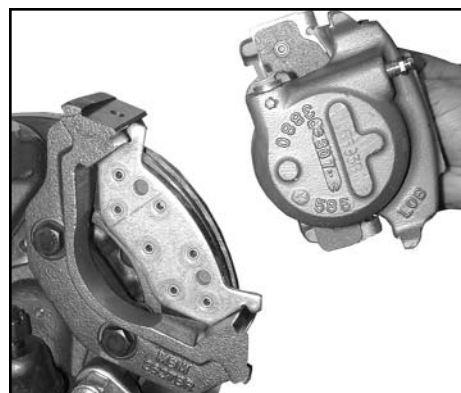

9. Place the black rubber band around the chrome retaining clips and install onto the caliper bracket as shown. (The larger clip goes on first followed by the smaller clip.)

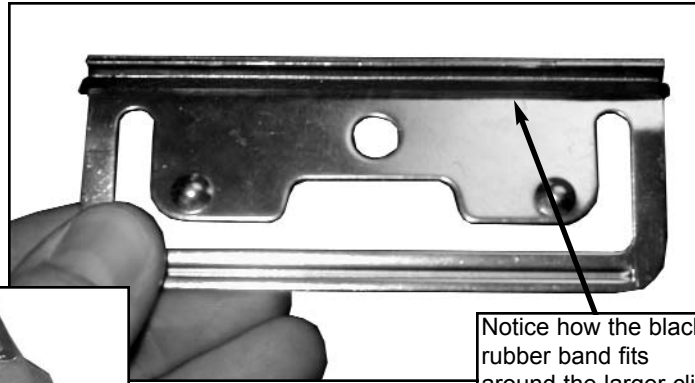

Notice how the black rubber band fits around the larger clip.

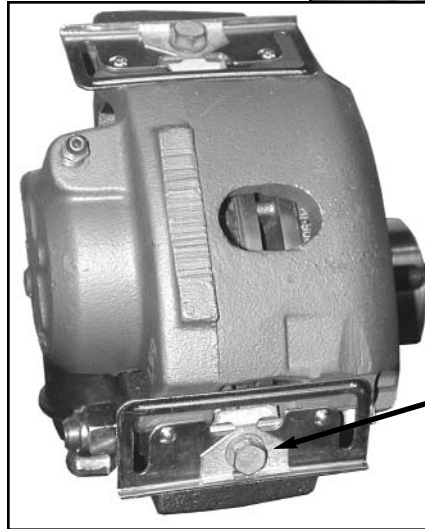

Notice how the clips are installed. The smaller clip is on top of the larger.

10. Install the caliper hose as shown on page 5.



INCORRECT



INCORRECT



CORRECT



CORRECT