



WARNING

Proper operation of your brakes is essential for your safety and the safety of others. Any brake service should be performed ONLY by persons experienced in the installation and proper operation of brake systems. It is the responsibility of the person installing any brake component or kit to determine the suitability of the component or kit for the particular application. After installation and before operating your vehicle, be sure to test the function of the brakes under controlled conditions.

DO NOT DRIVE WITH UNTESTED BRAKES!

FOR TECHNICAL ASSISTANCE CALL:

888-533-1199

MONDAY - FRIDAY

8:00 AM TO 5:00 PM EST

IMPORTANT

Take time to read all the literature that came with this kit. Check the provided list of parts against what you received to ensure all parts are present. While this kit was designed to make the process of changing brake parts as simple as possible. **NOTE: WITH SOME KITS IT MAY BE NECESSARY TO MAKE MINOR CHANGES TO YOUR CAR!**

READ ALL WARRANTY DISCLAIMERS AND RETURN POLICIES INCLUDED IN THIS KIT PRIOR TO INSTALLATION!

MASTER POWER BRAKES

110 CROSSLAKE PARK RD. MOORESVILLE, N.C. 28117

www.mpbrakes.com

BM1722

INSTALLATION INSTRUCTIONS

Your kit contains the following components:

- (1) Left bracket
- (1) Right bracket
- (1) Pedal push rod
- (1) Clevis with clevis pin
- (1) Jam nut 3/8 x 24
- (4) 8mm bracket nuts
- (2) Master cylinder mounting nuts
- (1) Firewall dust boot

Note: Right side indicates passenger side. Vacuum check valve on booster may go on top or bottom.

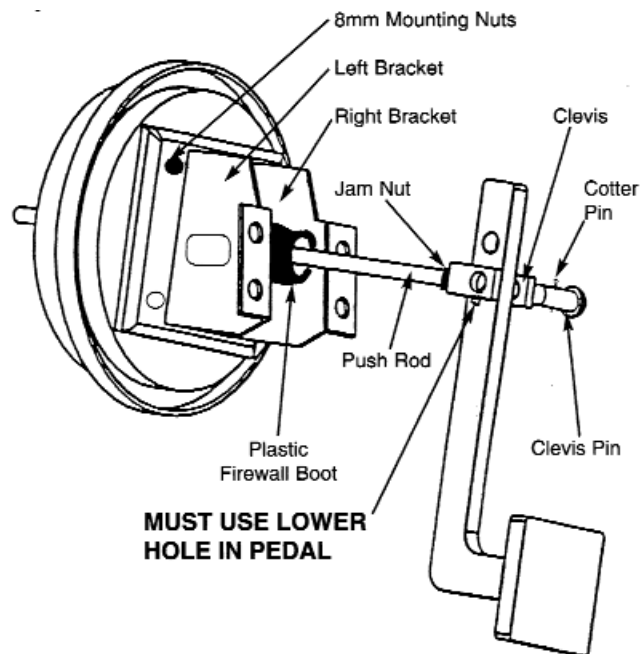

Installation Instructions:

1. Mount the supplied push rod and clevis to the back of the booster. Don't worry about length at this time. You will adjust it later.
2. Remove the original rubber boot from the booster and slide on the supplied boot
3. Install right and left mounting brackets onto the booster with supplied 8mm nuts.
4. Disconnect the original master cylinder brake lines.
5. Remove the original master from the firewall
6. If the vehicle was original power brakes the clevis will attach to the original location.
7. If the vehicle was manual brakes you will have to drill a hole 1" lower than the original hole on the pedal.
8. Mount the brake booster to the existing 3/8" studs on the firewall using the original nuts and lockwashers.
9. Adjust clevis to pedal height. Install clevis pin and cotter pin.
10. Bench bleed the master cylinder.
11. Mount the master to the booster and attach the brake lines.
12. Supply the booster with at least 18" vacuum from either the intake manifold or the back of the carburetor.
13. Run the lines as follows: The outlet closest to the master cylinder mounting flange will feed the rear and the outlet furthest from the mounting flange will feed the front.

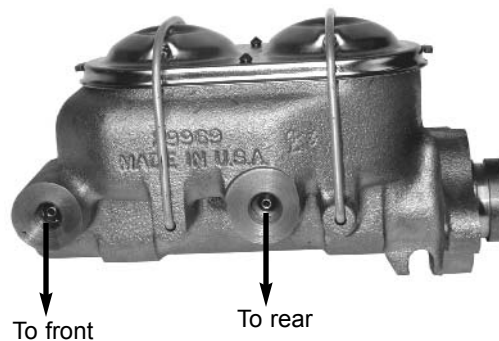

14. For a disc / drum system we recommend the use of a combination valve such as our VL3350. If using this valve plumb the system as follows.

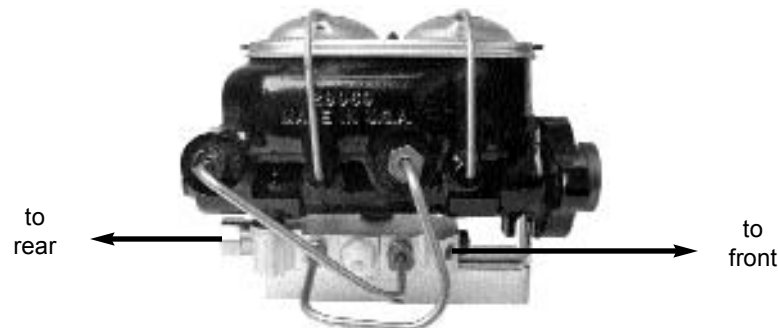

15. After attaching the hard lines bleed the system and test for pedal firmness. Test the brakes before driving.

FOR 1970 & UP GM A, B, F, X BODY

1. Remove the brake pedal from the vehicle.
2. Cut off the existing pin on the pedal where the push rod had attached.
3. Drill a 3/8" hole through the pedal in the same location as the pin.
4. Re install pedal.
5. Install booster as above.

BM1722 PARTS LIST BOOSTER/ MC, 9", 59-64 CHEVY

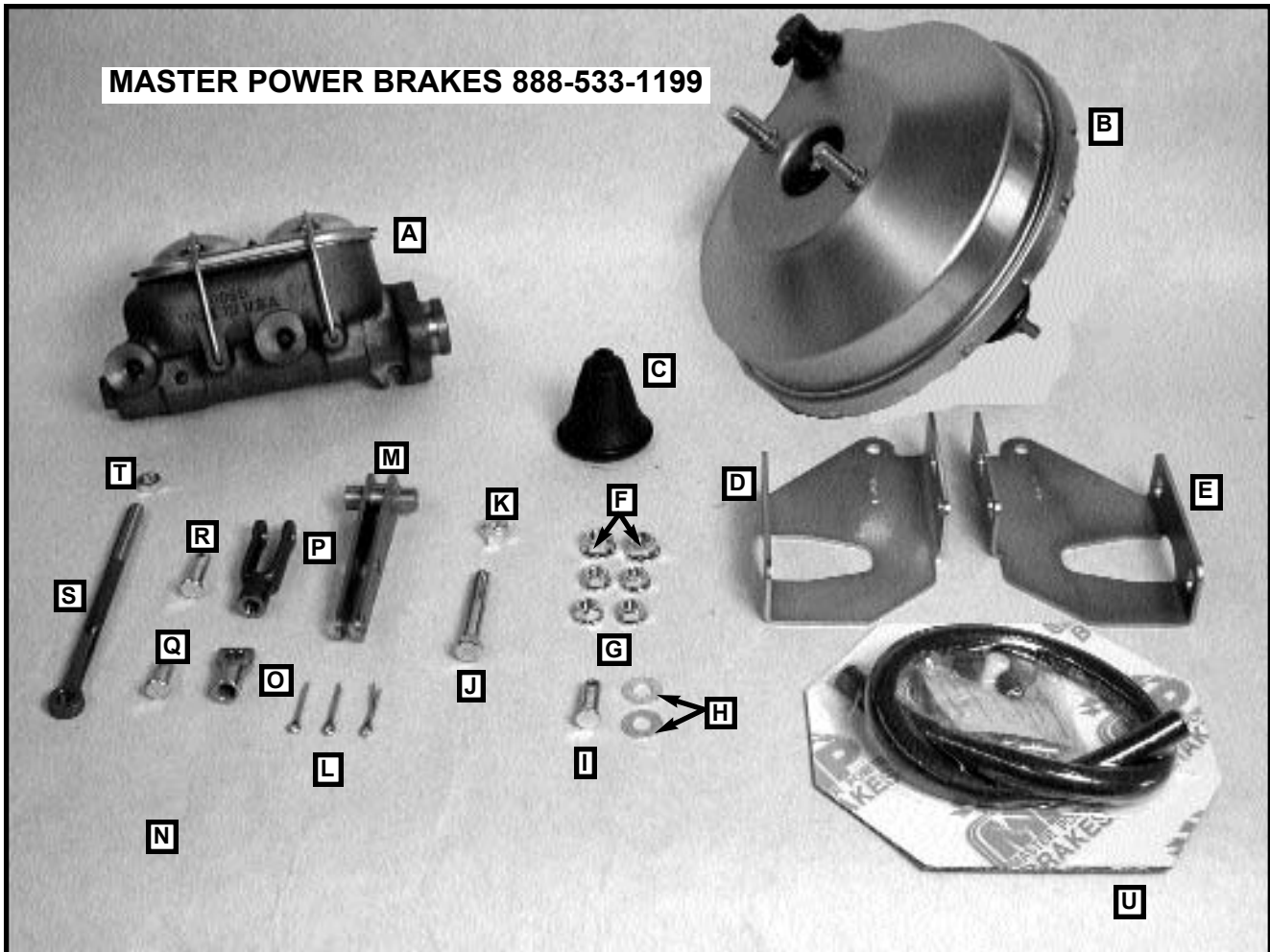

PARTS LIST

Revised 3/30/04

- A) (1) MC390545P MASTER, 1-1/8 BORE 4WD, CORVETTE MASTER
- B) (1) BS2004 BOOSTER, 9" SLIMLINE
- C) (1) HW2121 BOOSTER BOOT, 59-64 CHEVY
- D) (1) BR1721-OR BRACKET RIGHT 59-64 CHEVY ORG. STYLE
- E) (1) BR1721-OL BRACKET LEFT 59-64 CHEVY ORG. STYLE
- F) (2) 100CNWFZ NUT, M10, SERRATED FLANGE
- G) (4) 80CNWFZ NUT, M8-1.25, HEX FLANGE
- H) (2) 37NSAEFWZ WASHER, 3/8, FLAT ZINC GR-5
- I) (1) 37N100PCLZ PIN, 3/8 X 1 CLEVIS ZINC
- J) (1) 37C250HCS8Y BOLT, 7/16 X 2-1/2 COURSE
- K) (1) 37CNNEZ NUT, 3/8-16 NYLOCK ZINC
- L) (3) 12R100PCOZ COTTER PIN, 1/8 X 1"
- M) (1) PV1721-O PIVOT FOR BOOSTER KIT
- N) (4) BU1512 BUSHING .629 X .325 TH. SPACERS, BOOSTER
- O) (1) PR104 PUSH ROD, SHORT 3/8 HOLE
- P) (1) HW3719 CLEVIS PIN/ CAST IRON 3/8 X 24 THREAD/ FEMALE
- Q) (1) 37N75PCLZ 3/8 X 3/4 CLEVIS ZINC
- R) (1) 37N112PCLZ PIN, 3/8 X 1 1/8 CLEVIS
- S) (1) PR1721-01 PUSH ROD 7" IN LENGTH THREADED 3/8-24
- T) (1) 37FNFJOZ NUT, 3/8-24 HEX FINISH J-NUT ZINC
- U) (1) HS4001K HOSE KIT, VACUUM
 - (1) AC2002 BLEEDER KIT, USEDIN DUAL MASTER CYL. APPL.
 - (1) HS4001-2 VACUUM HOSE, 2FT PER KIT
 - (1) HW40066 FITTING, MALE ELBOW, 3/8 O.D. TUBE, 3/8 PIPE VAC. HOSE
 - (1) HW413-66 FITTING, MALE INVERTED 3/8 HOSE I.D., 3/8 O.D. MANIFOLD VAC. HOSE