



WARNING

Proper operation of your brakes is essential for your safety and the safety of others. Any brake service should be performed ONLY by persons experienced in the installation and proper operation of brake systems. It is the responsibility of the person installing any brake component or kit to determine the suitability of the component or kit for the particular application. After installation and before operating your vehicle, be sure to test the function of the brakes under controlled conditions.

DO NOT DRIVE WITH UNTESTED BRAKES!

FOR TECHNICAL ASSISTANCE CALL:

888-533-1199

MONDAY - FRIDAY

8:00 AM TO 5:00 PM EST

IMPORTANT

Take time to read all the literature that came with this kit. Check the provided list of parts against what you received to ensure all parts are present. While this kit was designed to make the process of changing brake parts as simple as possible. **NOTE: WITH SOME KITS IT MAY BE NECESSARY TO MAKE MINOR CHANGES TO YOUR CAR!**

READ ALL WARRANTY DISCLAIMERS AND RETURN POLICIES INCLUDED IN THIS KIT PRIOR TO INSTALLATION!

MASTER POWER BRAKES

110 CROSSLAKE PARK RD. MOORESVILLE, N.C. 28117

www.mpbrakes.com

BM1521KS

Booster & Master Parts List



Parts included in the box:

1. (1) Booster and Master unit with firewall gasket.
2. (1) Vacuum hose kit.
3. (1) Set of instructions.
4. (1) Power brake pedal for standard transmission.

Master Power Brakes
888-533-1199

BM1521KS

Installation Instructions

WARNING:

Installation of any component or kit should only be performed by persons experienced in the installation and proper operation of brake systems. It is also the responsibility of the person installing any brake component or kit to determine the suitability of the component or kit for that particular application.

NOTE:

Before operating the vehicle after installation test the function of the brakes under controlled conditions. Make several stops in a safe area from low speed and gradually work up to normal speeds. **DO NOT DRIVE WITH UNTESTED BRAKES!** Always utilize safety restraints when operating the vehicle.

STEP 1:

1. Check to be sure that your kit has all the necessary parts needed to complete this project! (Use the supplied parts list as a check list.)

STEP 2:

Remove the following components from your car:

Tech tip: Prior to disassembly spray the nuts and bolts that you will be removing with a penetrant. (Also disconnect the battery to eliminate the risk of draining the battery or an electrical short.)

1. Remove the old master cylinder from your car by first disconnecting the brake lines to the master cylinder. Next, remove the push rod from the brake pedal by removing the bolt located at the top of the pedal. Then remove the old master.
2. Now remove the original brake pedal.
3. Check for a positioning hole in the top of the pedal support. Most cars will have a 3/8" diameter hole on the top, towards the front of the car. If the hole is missing you must remove the pedal support and drill a 3/8" diameter hole in the proper location.

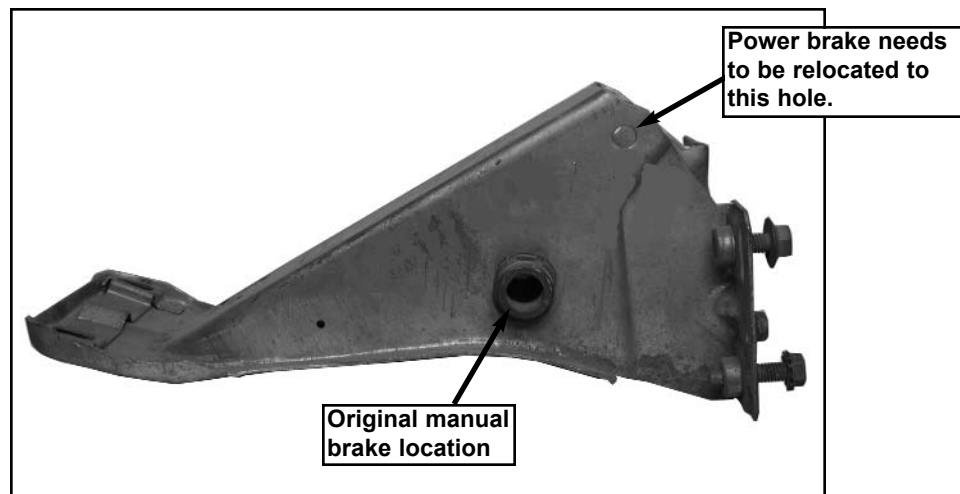

Picture of an original 67-70 Mustang pedal support. To install power brakes you must move the pedal pivot point from the manual brake location to the top hole in the pedal support. The hole is 3/8" in diameter. If the hole is missing you must remove the pedal support and drill a 3/8" diameter hole in the proper place.

STEP 3:

Things to prepare before assembly of the new booster & master kit.

1. Remove the new master cylinder from the booster assembly.
2. Bench bleed the new master cylinder to remove all the air. If all the air is removed from the master, then it will be difficult to push the piston in.

How to bench bleed:

Remove the master from the booster and place in a vice. (Be sure to clamp onto the mounting ear and not the cylinder.)

Install the proper size plugs in the outlet ports of the master.

Fill the master cylinder to the full line with brake fluid.

Use a rounded end rod or a phillips head screw driver and push the piston in repeatedly until no bubbles are visible.

NOTE: This may take a minute or two of continuous pumping!

STEP 4:

Installation of booster & master components:

1. Slide the pedal up into the pedal support and insert the bolt through the top hole of the support. Do not over-tighten the nut with nylon insert. The pedal must be free from binding. (If your car originally had a power brake system you will use your original pedal. If it was a manual brake system, then you will use the one that was supplied with your specific kit.)
2. Now drill new holes corresponding to the booster mounting studs. Also, open up the area above the large hole in the firewall for added clearance using the gasket as a template. **(As shown in the diagram.)**
Note: Warranty is void if sufficient clearance is not provided.
3. Install the booster with firewall gasket to the firewall using the supplied hardware. Then attach the booster push rod to the pedal. **(As shown in the diagram.)**
4. Mount the master cylinder to the booster. **(Make sure that the master was properly bled.)**

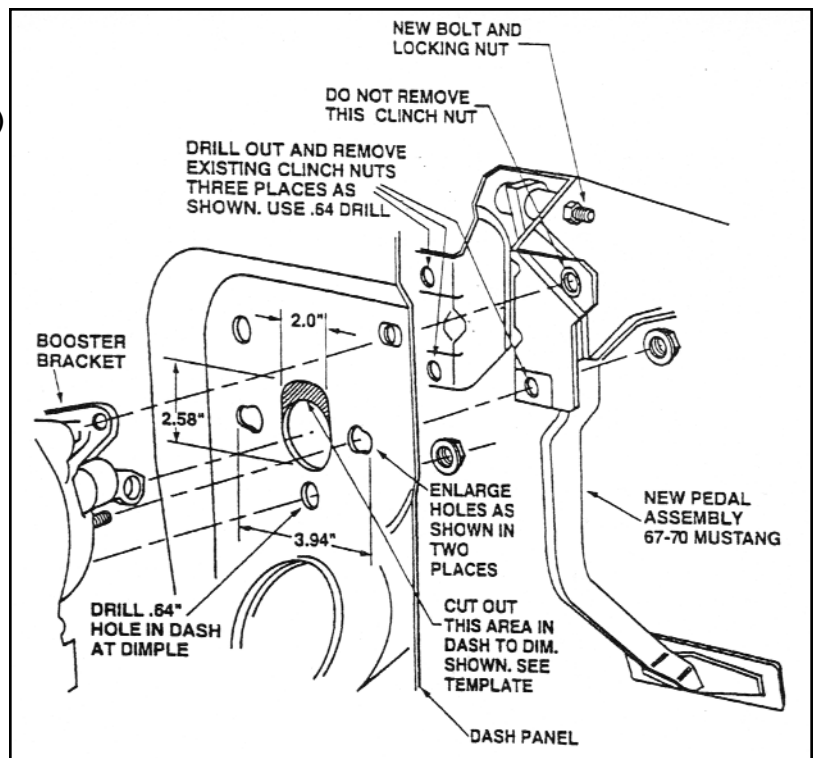
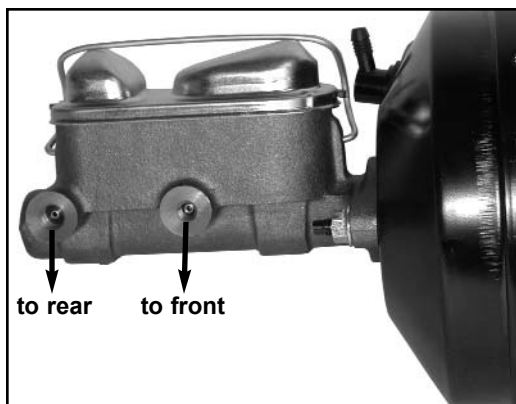

5. Connect the vacuum fitting and the hose to either the intake manifold or to the rear of the carburetor. Make sure that the vacuum source on the carburetor is manifold vacuum and not timed vacuum. **Note: The engine must provide a minimum of 18" of vacuum for the booster to work effectively.**
6. Attach the brake lines to the master. **(If your brake kit came with a combination valve then it is important that you remove any factory installed valves from the system. Failure to do this could result in a nonfunctional brake system.)** Then install the combination valve.

7. Run the rear line to the rear outlet on the combination valve. There are two outlets for the front wheel on the combination valve. You have the option of running a line from each wheel to each outlet or running both lines to a T-fitting and then into one of the front outlets. **(In this scenario, you will have to plug the unused outlet.)** Either way is acceptable and neither routing has improved braking performance over the other. **(Be sure to keep all lines away from exhaust, steering or other things that could harm them.)**

9. When the valve is plumbed correctly and all hard lines are attached, bleed the entire system.

10. If you are not using a combination valve, or you have four wheel drum brakes, you will need to run one line from the master cylinder to the front and one to the rear. The outlet closest to the booster will feed the front brakes. We recommend that you use a 10lb residual valve on both the front and rear drum brakes to provide a firmer pedal feel.

10. Reconnect the battery and start the engine. Test the brakes. If the pedal goes to the floor or is very spongy then bleed the system once again.

11. Test drive the car in a safe location before driving.

