



WARNING

Proper operation of your brakes is essential for your safety and the safety of others. Any brake service should be performed ONLY by persons experienced in the installation and proper operation of brake systems. It is the responsibility of the person installing any brake component or kit to determine the suitability of the component or kit for the particular application. After installation and before operating your vehicle, be sure to test the function of the brakes under controlled conditions.

DO NOT DRIVE WITH UNTESTED BRAKES!

FOR TECHNICAL ASSISTANCE CALL:

888-533-1199

MONDAY - FRIDAY

8:00 AM TO 5:00 PM EST

IMPORTANT

Take time to read all the literature that came with this kit. Check the provided list of parts against what you received to ensure all parts are present. While this kit was designed to make the process of changing brake parts as simple as possible. **NOTE: WITH SOME KITS IT MAY BE NECESSARY TO MAKE MINOR CHANGES TO YOUR CAR!**

READ ALL WARRANTY DISCLAIMERS AND RETURN POLICIES INCLUDED IN THIS KIT PRIOR TO INSTALLATION!

MASTER POWER BRAKES

110 CROSSLAKE PARK RD. MOORESVILLE, N.C. 28117

www.mpbrakes.com



BM1008

8" BOOSTER WITH MASTER

INSTALLATION INSTRUCTIONS



MASTER POWER BRAKES

110 CROSSLAKE PARK RD MOORESVILLE N.C. 28117

www.mpbrakes.com 704-664-8866



REVISED 050302

INSTALLATION INSTRUCTIONS

INCLUDED COMPONENTS

Your BM1008 kit should contains the following components:

1. 8" dual diaphragm power booster
2. Dual outlet master cylinder
3. Booster check valve
4. Bleeder kit (not shown)

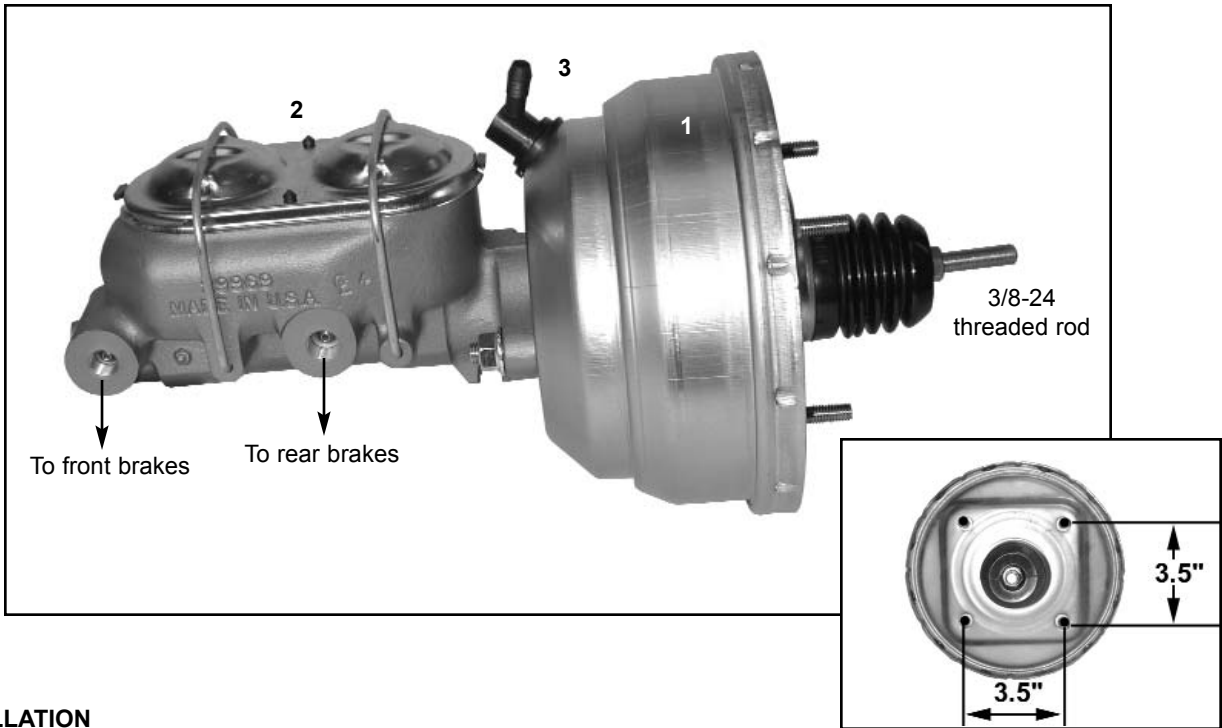

INSTALLATION

The BM1008 dual diaphragm power booster with master cylinder is designed to work with disc/drum systems or with four wheel disc. Use of this booster with front drum brakes will give an extremely sensitive pedal. This booster will directly replace the 7" street rod booster.

1. Mounting the BM1008 power booster requires that four holes exist or be drilled with a 3 1/2 x 3 1/2 pattern.
2. Proper operation of this booster will require a 4:1 to 5:1 pedal ratio. A higher ratio will produce too sensitive a pedal.
3. Mount the booster to your firewall or existing power brake pedal assembly and secure with the supplied nuts.
4. Connect the threaded rod from the back of the booster to your pedal using the correct clevis or swivel eye. For proper function the linkage from the pedal must go into the booster in a straight line. An angled entry will cause booster problems. You must have at least 18" vacuum for proper booster function.
5. Bench bleed the master cylinder to remove all air.
6. Mount the master to the booster and secure.
7. Plumb the master into the system as above.

It is recommended that you use the correct combination valve to balance your system such as our VL3350 disc/drum valve or our VL3359 disc/disc valve.

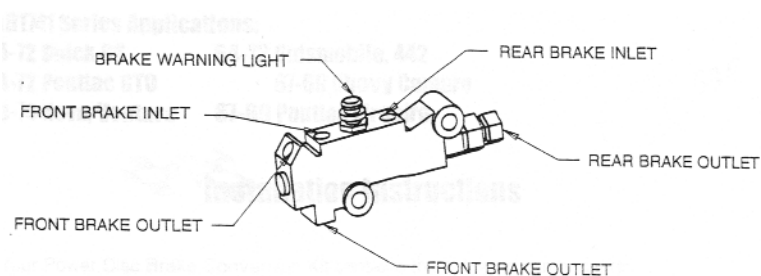

**BM1008
PARTS LIST
8" BOOSTER WITH MASTER**

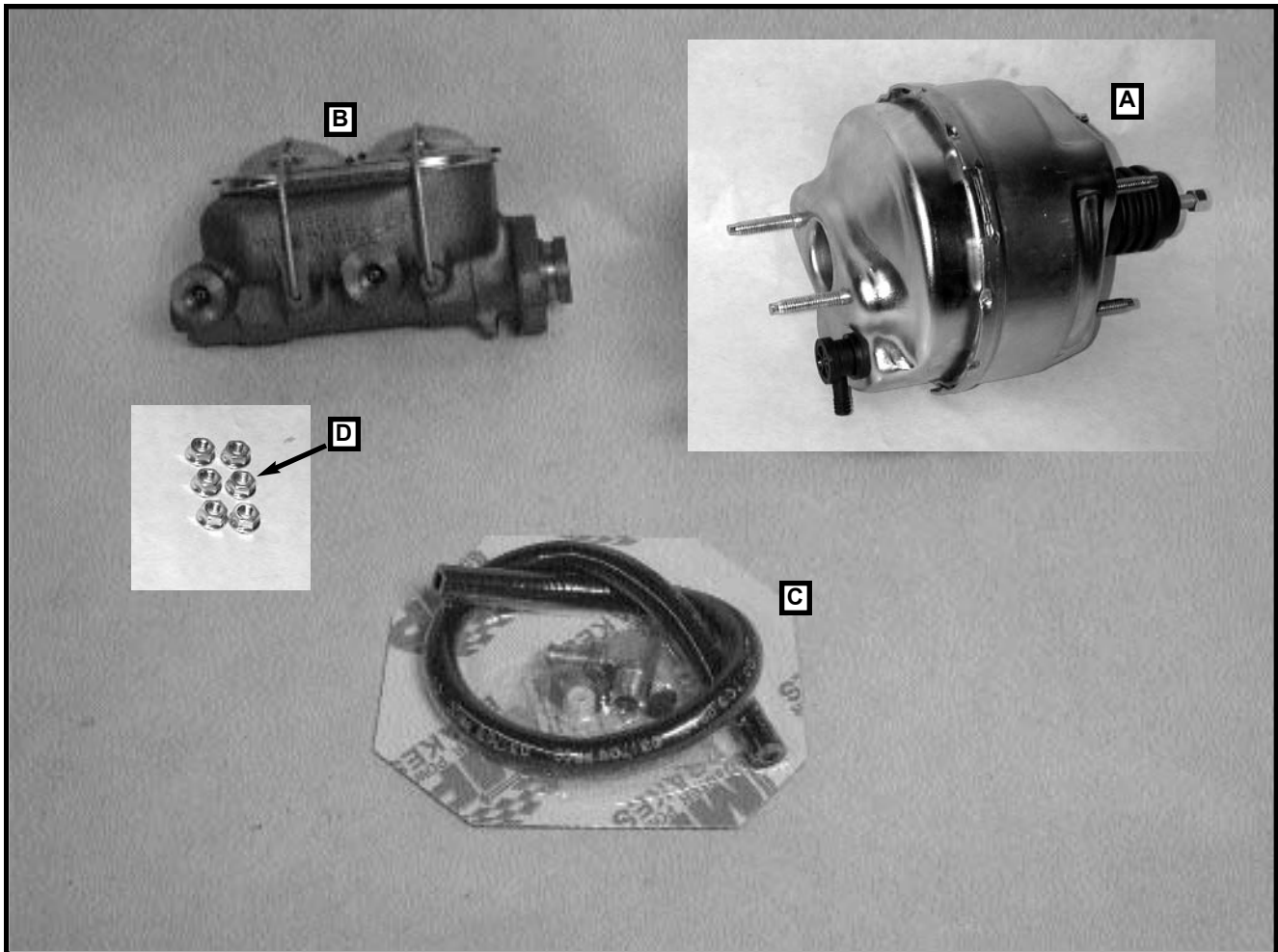

PARTS LIST

- A) (1) BS8001 BOOSTER 8" DUAL DIAMETER
- B) (1) MC390360P MASTER CYLINDER, POWER,
GM 1" BORE, 7/16" STROKE, DUAL RESERVOIR/
FENDER SIDE
- C) (1) HS4001K HOSEKIT, VACUUM
 - (1) AC2002 BLEEDER KIT, USED IN DUAL MASTER CYLINDER
APPLICATION
 - (1) HS4001-2 VACUUM HOSE, 2 FT. PER KIT
 - (1) HW40066 FITTING, MALE ELBOW, 3/8 O.D. TUBE, 3/8 PIPE
VACUUM HOSE
 - (1) HW413-66 FITTING, MALE INVERTED 3/8 HOSE I.D., 3/8 O.D.
MANIFOLD VACUUM HOSE
- D) (6) 37CNFWZ 3/8-16, WHIZ FLANGE ZINC

MASTER POWER BRAKES 888-533-1199

Revised 10/7/03