



MASTER POWER BRAKES

110 Crosslake Park Drive, Mooresville, NC 28117

Website: www.mpbrakes.com

Technical Support: 888-533-1199

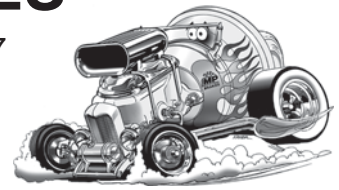

WARNING

Disc brake conversions require disc brake wheels. Drum brake wheels will not clear the disc brake calipers.

Minimum specifications for a disc brake wheel:

1. Correct bolt circle
2. Large center hole to clear the rotor hub center
3. 15"X 7"
4. 3 3/4" backspace
5. Wheel drop center (spokes) that clear caliper

Must have 15" or larger wheels. Wheel fitment is customers responsibility.

Proper operation of your brakes is essential for your safety and the safety of others. Any brake service should be performed **ONLY** by persons experienced in the installation and proper operation of brake systems. It is the responsibility of the person installing the component or kit for the particular application. After installation and before operating your vehicle, be sure to test the function of the brakes under controlled conditions.

//////////////////// **DO NOT DRIVE WITH UNTESTED BRAKES!** //////////////////////
FOR TECHNICAL ASSISTANCE CALL:

888-533-1199

MONDAY - FRIDAY

8:00 A.M. TO 5:00 P.M. E.S.T.

CHECK ORDER IMMEDIATELY WARRANTY INFORMATION

Take time to read all the literature that came with this kit. Check the provided list of parts against what you received to ensure all parts are present. While this kit was designed to make the process of changing brake parts as simple as possible, **with some kits it may be necessary to make minor changes to your car.**

Read all warranty disclaimers and return policies included in this kit prior to installation.

You have: **5 days** to declare shipping damages
30 days to declare missing or incorrect parts
90 days for exchanges or returns (RA req'd)
1 year before product warranty expires.

No exceptions allowed.

Thank you for your business!

**WARRANTY: Void if
silicone fluid is used in
system**

See the following page



110 Crosslake Park Road, Mooresville, NC 28117

Website: www.mpbrakes.com Technical Support: 888-533-1199

© 2011 MP Brakes. All rights reserved. Master Power® is a registered trademark of Master Power Brakes, LLC

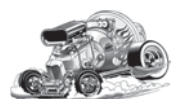



MASTER POWER BRAKES

110 Crosslake Park Drive, Mooresville, NC 28117

Website: www.mpbrakes.com

Technical Support: 888-533-1199



BRAKE FLUID WARNING

- The EPDM rubber used in brake components is not compatible with silicone brake fluid.
- Silicone brake fluid does compress, glycol based fluid will not.
- Silicone brake fluid will not absorb water, glycol based fluid will. Due to the fluctuations in temperature which causes condensation, water will get into any brake system. Since silicone fluid will not absorb water you will have pockets of water in critical brake components leading to corrosion and brake failure. Brake fluid, as per any automotive manufacturer, should be replaced as part of a regular maintenance routine.
- Silicone brake fluid can lead to premature wear due to the expansion of rubber components. This expansion can cause serious braking issues such as, sticking pistons on calipers and master cylinders and hose failure.
- We recommend using a high quality DOT 4 fluid like our Pentosin Super DOT 4.



General Torque Specifications

General Torque Specifications (Non-Nylock)					
Bolt Size	Grade	Torque	Bolt Size	Grade	Torque
1/4"	5	10	1/4"	8	14
3/8"	5	33	3/8"	8	47
7/16"	5	54	7/16"	8	78
1/2"	5	78	1/2"	8	119
9/16"	5	114	9/16"	8	169
5/8"	5	154	5/8"	8	230

General Torque Specifications (Nylock)					
Bolt Size	Grade	Torque	Bolt Size	Grade	Torque
1/4"	5	13	1/4"	8	17
3/8"	5	42	3/8"	8	56
7/16"	5	65	7/16"	8	89
1/2"	5	95	1/2"	8	136
9/16"	5	139	9/16"	8	194
5/8"	5	189	5/8"	8	265



MASTER POWER BRAKES

110 Crosslake Park Road, Mooresville, NC 28117

Website: www.mpbrakes.com Technical Support: 888-533-1199

© 2006 MP Brakes. All rights reserved. Master Power ® is a registered trademark of Master Power Brakes, LLC



rev. 9/23/11

Installation Instructions

DB1504B
49-53 FORD
DISC KIT

INCLUDED COMPONENTS:

1. Calipers with pads
2. Caliper mounting brackets and hardware
3. Rotors
4. Bearings and seals
5. Rubber hoses with hose bolts



BEFORE GETTING STARTED STRIP ALL THE OLD BRAKES, BACKING PLATES, STEERING ARMS, AND GUNK FROM FORD SPINDLES.

STEP 1:

DISC BRAKE ASSEMBLY

Start with a clean spindle.



STEP 2:

Install bearing adapter.

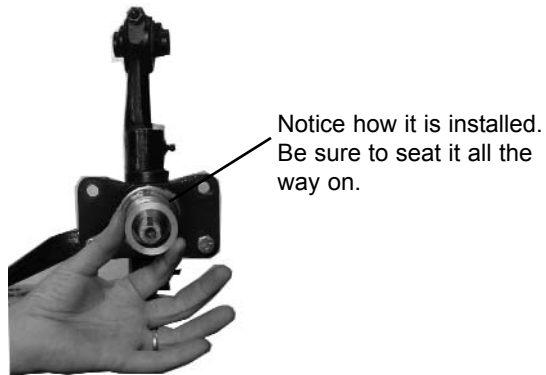

STEP 3:

Install the triangular bracket to the inside of the two top spindle holes, with the tapped hole in the new bracket toward the front.

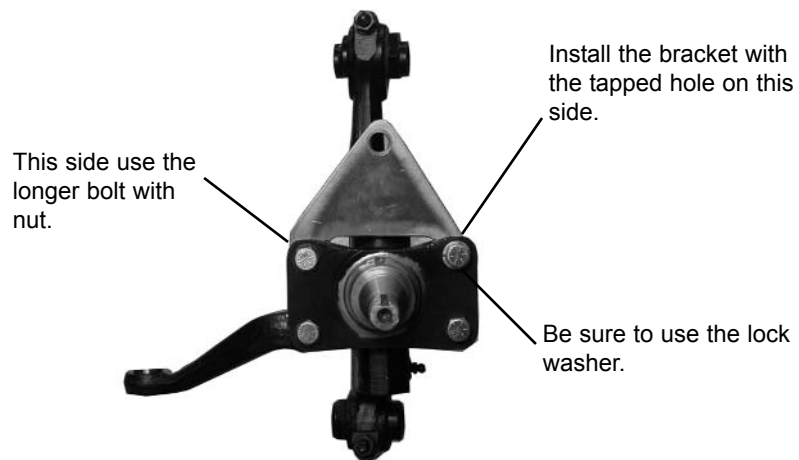

STEP 4:

Now attach the caliper bracket to the triangular bracket, using the tube spacer in between. The lower end of the caliper bracket fits over the forward boss of the steering arm and uses the stock bolt. Due to variances in steering arms, you may need to grind the bracket slightly (as shown in Figure 2) in order to get the lower securely in place.

Figure 1.

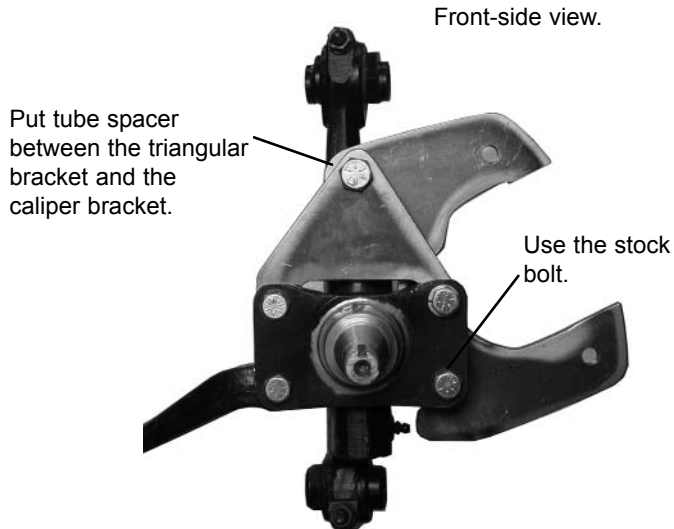
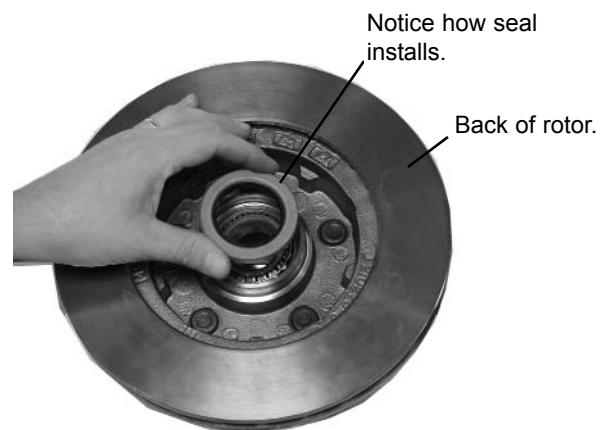
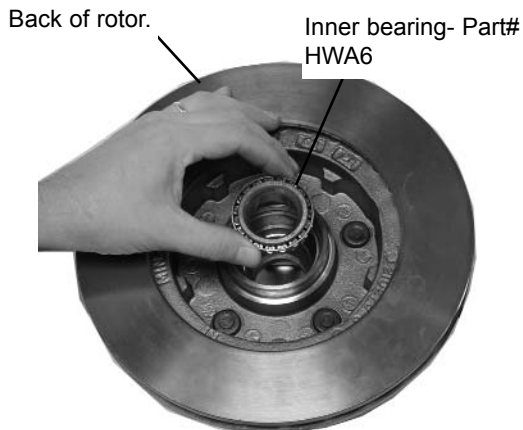

Figure 2.



STEP 5:

Grease and install the inner bearing in back of rotor. After greasing the inner bearing, install the rotor seal. Tap the seal into place with a small hammer so it fully seats.



BE SURE TO GREASE BEARINGS WITH A HIGH QUALITY BEARING GREASE.

STEP 6:

Install rotor onto the spindle (as shown in Figure 1). Then install the outer bearing (as shown in Figure 2). **BE SURE TO GREASE.** After completing this, install the stock Ford spindle washer, followed by the large flat washer, then the spindle nut. Tighten the spindle nut until it is snug and rotor does not spin freely. Back off the nut slightly until the rotor spins freely . Now install the cotter pin and bend it over.

FIGURE 1.

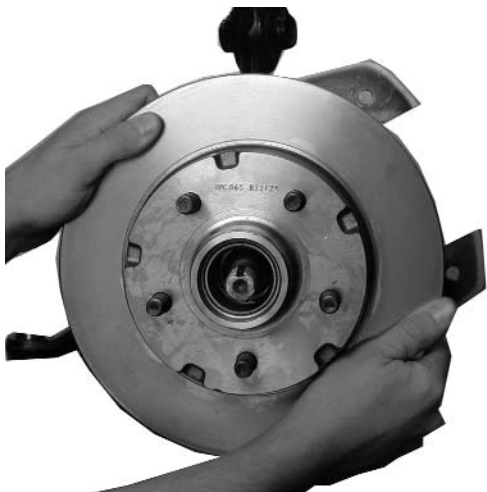
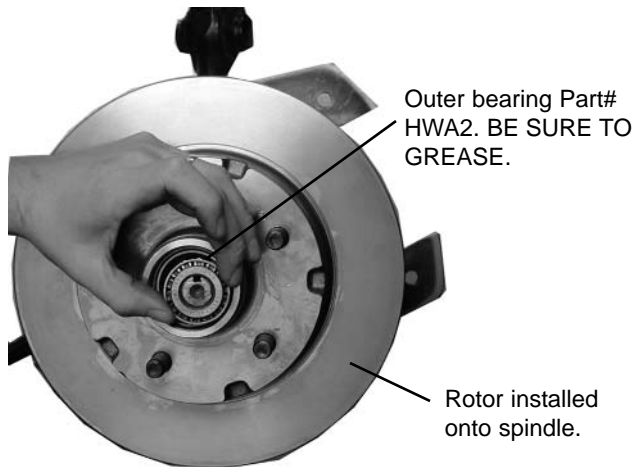
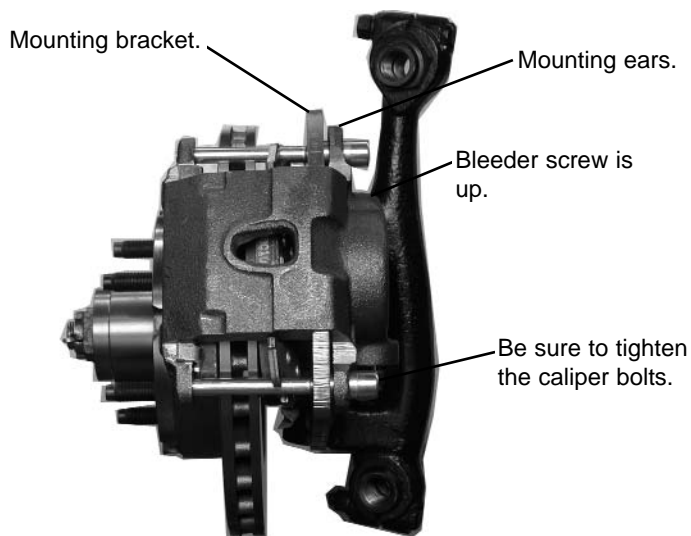

FIGURE 2.



STEP 7:

Install the caliper with pads using the supplied hardware. Remember the caliper bracket fits between the caliper and the mounting ears. (Bleeder screw up.) Once installed turn to be sure everything runs true.



STEP 8:

Be sure to mount the brake hoses to clear all suspension parts throughout full turn and suspension travel. Once you have completed that install the tire and wheel, check closely for adequate wheel clearance on the caliper before you turn the wheel. (Also check for wheel well clearance.) If all is well turn the wheel very slowly to be sure there are no points of interference. If everything checks out OK, move on to the next step.

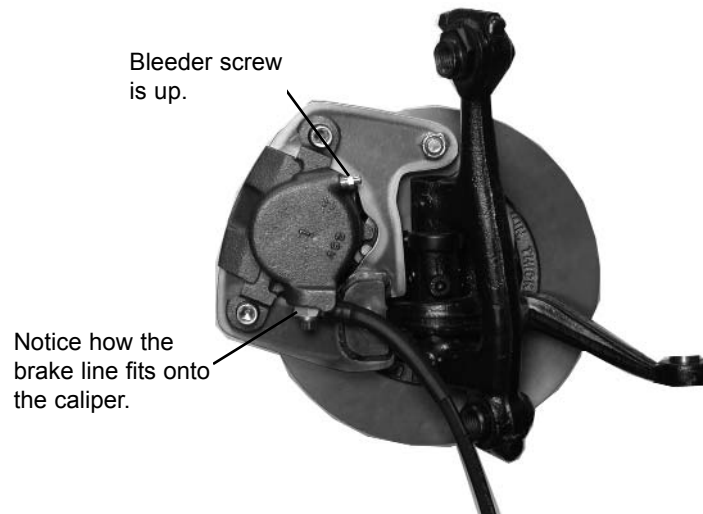

STEP 9:

Since disc brakes will drag if used with a drum brake master cylinder, you must make some changes. If you are using a late model firewall mounted master cylinder, be sure it is set up for front disc brakes. If you are using a stock 49-53 Ford master cylinder, you will need to remove the original residual pressure valve inside, and use a 10 psi inline residual pressure valve (available from us).

DB1504B
DISC BRAKE KIT, LOWER, 49-53 FORD, 52-53 MERC.
PARTS LIST

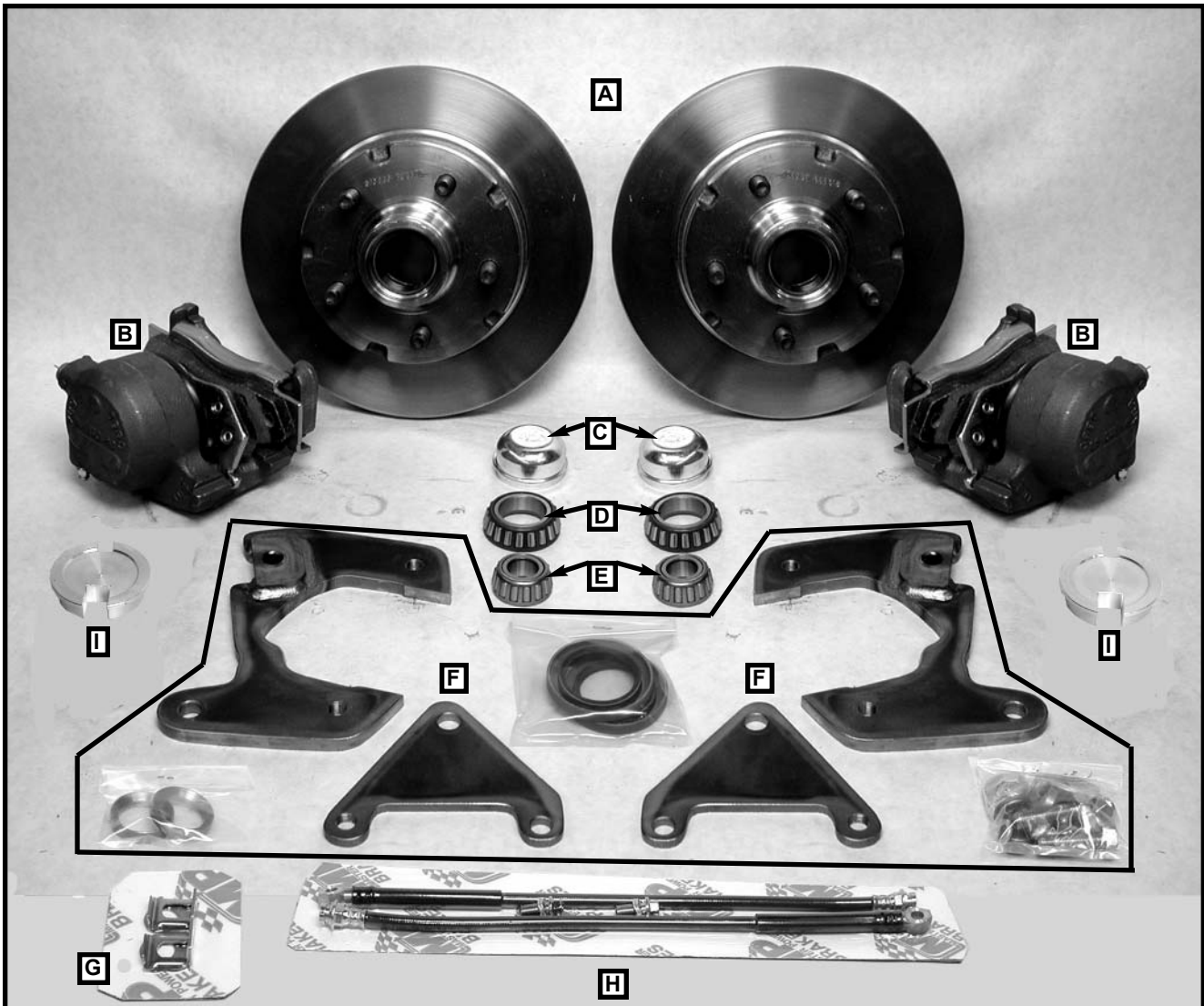

PARTS LIST

- A) (2) RT141264 ROTOR, 49-53 FORD
- B) (2) CA412526 CALIPERS, SET SMALL GM USED IN DROP SPINDLE APPL.
- C) (2) HW503 FORD DUST CAPS TRUCK 86-92 AEROSTAR; RANGER
- D) (2) HWA6 BEARING, INNER
- E) (2) HWA2 BEARING, OUTER
- F) (1) BRECI721F BRACKET KIT 49-53 FORD
- G) (1) BR3737K BRACKETS, HOSE CLIPS 1 PAIR
 - (2) BR3737 BRACKET, HOSE
 - (2) HW8708 BRAKE HOSE CLIP
- H) (1) HS5157K HOSE KIT, 18" HOSES 10MM
 - (2) HS5157 HOSE, 18" 10MM HOSE
 - (4) HW21206 WASHER, COPPER USED FOR METRIC HOSE BOLT
 - (2) HW5155 10MM METRIC BOLT COURSE
- I) (2) AD412526 ADAPTOR, PAD SPACER

MASTER POWER BRAKES 888-533-1199

Revised 8/25/10